



GB-410 SERIES™, GB-414 SERIES™, GB-425 SERIES™

EXTERNAL GEAR PUMPS FOR GREENER ENERGY SOLUTIONS

- Carbon capture dehydration in biofuel refinement, hydrogen production, oil & gas processing, and energy generation
- Renewable natural gas processing, landfill gas processing, carbon sequestering
- Blue & green fuel transfer, processing, and pipeline injection

ENVIRONMENTALLY FRIENDLY FEATURES & BENEFITS

ELECTRIC MOTOR DRIVEN

- NO wasting of motive gas
- NO flaring (CO₂) or venting (Methane) emission contributions
- Volumetric & mechanically efficient power solutions

NO VIBRATION – SMOOTH, NON-PULSATING FLOW

- NO risk of vibration cracking piping or causing leakage
- NO pulsation dampeners needed

ROBUST MECHANICAL SEAL

- Reduce chance of product leakage or spills
- NO leaking packed shaft seals like reciprocating pumps
- NO flimsy lip seals prone to product leakage

GB SERIES™ HIGH-PRESSURE PUMPS ARE IDEAL FOR:

- Renewable energy processing
- Upstream oil & gas processing
- Natural gas dehydration
- Carbon capture dehydration
- Hydrogen & syngas processing & production
- Renewable natural gas dehydration & processing

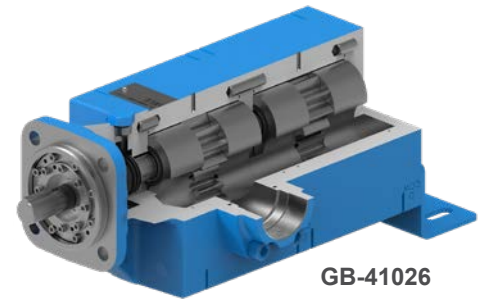

GB-41026

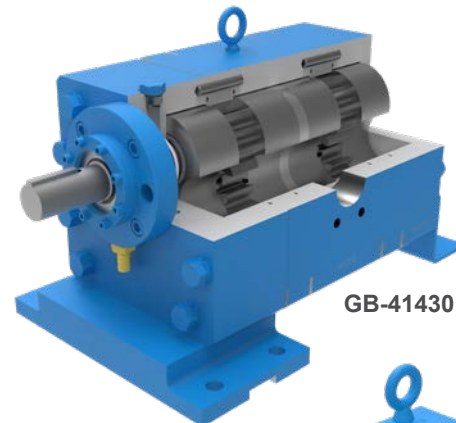

GB-41430

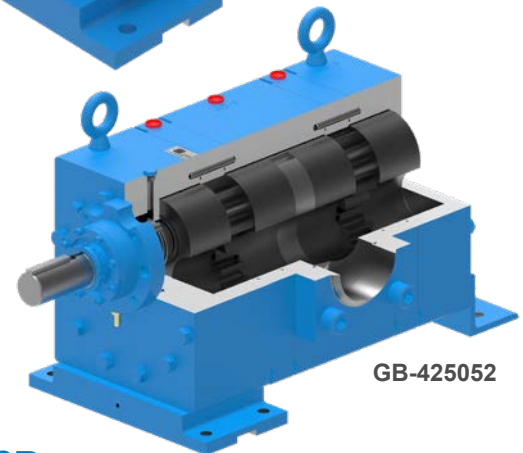

GB-425052



Viking Pump® has partnered with [OneTreePlanted.org](https://www.onetreeplanted.org) to plant 10,000 trees annually. Every tree planted makes a positive impact for nature, wildlife and people.



One Tree Planted is a 501(c)(3) nonprofit dedicated to global reforestation. They plant trees to restore nature and biodiversity. They also raise awareness about the importance of trees and offer businesses like ours a simple sustainability solution.

PERFORMANCE

Pump Model	Port Size	Nominal Flow at Maximum Pressure on 4 cPs Liquid		Max Continuous Pressure	Max Recommended Temperature	Approximate Shipping Weight
Ductile Iron Externals	Inch	GPM	BPD	PSI	Deg. F	Lbs.
GB-41005	2"	7.5	260	1500	350	70
GB-41007	2"	11	376	1500	350	72
GB-41009	2"	13.4	459	1500	350	73
GB-41013	2"	21	725	1500	350	77
GB-41018	2"	27	932	1500	350	117
GB-41022	2"	35.5	1220	1500	350	120
GB-41026	2"	43	1483	1500	350	124
GB-41039	2"	66	2268	1500	350	170
GB-41415	2"	40	1366	1500	350	225
GB-41420	2"	60	2045	750	350	233
GB-41430	2"	81	2779	1500	350	322
GB-41440	3"	120	4138	750	350	334
GB-41445	3"	122	4202	1500	350	437
GB-41455	3"	168	5760	750	350	453
GB-41460	4"	182	6230	750	350	500
GB-425021	6"	150	5,100	1500	350	1375
GB-425052	6"	298	10,200	1500	350	1786
GB-425073	6"	446	15,300	1500	350	2473
GB-425051	6"	340	11,720	750	350	1500
GB-425102	6"	685	23,440	750	350	2037

THE VIKING PUMP ADVANTAGE

- With over 110 years of experience providing positive displacement pumping solutions, Viking Pump has a rich, lengthy history of providing engineered solutions for tough applications
- Dedicated sales and field support specialists are supported by a team of customer service representatives and engineers
- Knowledgeable team of application engineers available to help with product selection and technical support
- USA based company with vertically integrated manufacturing facility



ALL PUMPS FACTORY TESTED

State of the art testing equipment used to confirm performance prior to all shipments



TEST LAB

Our world-class lab gives Viking Pump the ability to test our pump designs across a range of relevant variables



VIKING PUMP, INC.
 A Unit of IDEX Corporation
 406 State Street
 Cedar Falls, Iowa 50613 U.S.A.
vikingpump.com

CONTACT YOUR VIKING PUMP ENERGY SPECIALISTS:

Yohance Henry | yhenry@idexcorp.com | (519) 259-4268
Steve Kettner | skettner@idexcorp.com | (403) 831-7756

