



INSTALLATION, OPERATION
AND
MAINTENANCE MANUAL
FOR THE



RANGE OF PUMPS



INSTALLATION, OPERATION AND MAINTENANCE MANUAL FOR RTP™ ROTARY LOBE PUMPS.

1.0	<u>SAFETY INFORMATION.</u>	3
1.1	RISK ASSESSMENT RELATING TO THE USE OF WRIGHT FLOW TECHNOLOGIES LIMITED. RTP ROTARY LOBE PUMPS AND PUMP UNITS IN POTENTIALLY EXPLOSIVE ATMOSPHERES.	6
2.0	<u>INTRODUCTION.</u>	7
2.1	GENERAL.	7
2.2	WRIGHT FLOW TECHNOLOGIES LIMITED. DISTRIBUTORS.	7
2.3	RECEIPT AND STORAGE.	7
2.4	CLEANING.	8
2.5	PUMP MODEL DESIGNATION.	8
2.5.1	ATEX INFORMATION PLATE	9
2.6	PUMP MODEL AND SERIAL NUMBER.	10
3.0	<u>GENERAL.</u>	11
3.1	RTP™ PUMPING PRINCIPLE.	11
3.2	RTP™ OPERATING PARAMETERS.	12
3.3	SYSTEM DESIGN AND INSTALLATION.	12
3.3.2	INSTALLATION WITH CIP SYSTEMS.	15
3.4	START UP PROCEDURE.	16
3.5	SHUTDOWN PROCEDURE.	17
3.6	ROUTINE MAINTENANCE.	17
3.7	HEATING AND COOLING DEVICES	17
3.8	INTEGRAL PRESSURE RELIEF VALVE.	19
4.0	<u>RTP™ PUMP DISMANTLING AND ASSEMBLY.</u>	21
4.1	DISASSEMBLY.	22
4.1.1	FRONT COVER AND ROTOR REMOVAL	22
4.1.2	GEARBOX DISMANTLING	23
4.1.3	SHAFT DISASSEMBLY.	25
4.2	ASSEMBLY.	26
4.2.1	GEARBOX & ROTORCASE ASSEMBLY,	26
4.2.2	SHAFT ASSEMBLY – RTP20	27
4.2.3	SHAFT ASSEMBLY – RTP30	28
4.2.4	TIMING.	29
4.2.5	SETTING THE ROLLING TORQUE.	31
4.2.6	ROTOR CLEARANCES.	31
4.3	PRODUCT SEAL FITTING AND REMOVAL.	32
4.3.1	GENERAL PROCEDURES FOR INSTALLING SEALS.	32
4.3.2	RTP20 O-RING SEAL REMOVAL AND INSTALLATION.	34
4.3.3	RTP20 MECHANICAL SEAL.	36
4.3.4	RTP30 CLASS 1 HYGIENIC MECHANICAL SEAL.	37
4.3.5	RTP30 CLASS 2 HYGIENIC MECHANICAL SEAL.	38
4.3.6	RTP30 STANDARD RADIAL LIP SEAL.	39
4.3.7	RTP30 O-RING SEAL.	40

5.0	SPECIFICATIONS.	41
5.1	CLEARANCE CHART	41
5.2	FASTENERS & TORQUE SETTINGS.	42
5.3	LUBRICANTS.	43
5.4	TOOL LIST.	44
5.5	RTP30 FOUNDATION DIMENSIONS – STUB SHAFT DRIVE.	45
5.5.1	RTP20 AND 30 FOUNDATION DIMENSIONS – BASIC PUMP (HYDRAULIC DRIVE)	46
5.6	TYPICAL BASIC PUMP BUILD	48
5.7	TROUBLE SHOOTING.	49
5.8	RTP™ SERVICE HISTORY.	50
5.9	NOTES.	51

1.0 Safety Information.

INCORRECT INSTALLATION, OPERATION, OR MAINTENANCE OF EQUIPMENT MAY CAUSE SEVERE PERSONAL INJURY OR DEATH AND/OR EQUIPMENT DAMAGE THAT MAY INVALIDATE THE WARRANTY.

THIS INFORMATION MUST BE READ FULLY BEFORE BEGINNING INSTALLATION, OPERATION, OR MAINTENANCE AND MUST BE KEPT WITH THE PUMP. ONLY SUITABLY TRAINED OR QUALIFIED PERSONS SHOULD UNDERTAKE INSTALLATION AND MAINTENANCE.

Danger - Failure to follow the listed precautionary measures may result in serious injury or death. Areas of potential risk are identified by the following symbol:



Warning - Safety instructions which shall be considered for reasons of safe operation of the pump or pump unit and/or protection of the pump or pump unit itself are marked by the sign:

WARNING

DANGER

DO NOT OPERATE PUMP IF:



- The front cover is not installed correctly.
- Any guards are missing or incorrectly installed.
- The suction or discharge piping is not connected.



DO NOT place fingers, etc. into the pumping chamber or its connection ports or into any part of the gearbox if there is ANY possibility of the pump shafts being rotated. Severe injury will occur.



DO NOT exceed the pumps rated pressure, speed, and temperature, or change the system/duty parameters from those for which the pump was originally supplied, without confirming its suitability for the new duty. Running the pump outside of its operations envelop can cause mechanical contact, excessive heat and can represent a serious risk to health and safety.



Installation and operation of the pump must always comply with health and safety regulations.

A device must be incorporated into the pump, system, or drive to prevent the pump exceeding its stated duty pressure. It must be suitable for both directions of pump rotation where applicable. Do not allow pump to operate with a closed/blocked discharge unless a pressure relief device is incorporated. If an integral relief valve is incorporated into the pump, do not allow re-circulation through the relief valve for extended periods; (refer to section 3.8).

WARNING



The mounting of the pump or pump unit should be solid and stable. Pump orientation must be considered in relation to drainage requirements. Once mounted, shaft drive elements must be checked for correct alignment. Rotate pump shaft by at least one full revolution to ensure smoothness of operation. Incorrect alignment will produce excessive loading, create high temperatures and increased noise emissions. Do not use any drive arrangements, which cause side loading of the drive shaft. It may also be necessary to earth the pump head to avoid the build up of a potential charge difference that could cause a spark.



The installation must allow safe routine maintenance and inspection (to replenish lubricants, check for leakage, monitor pressures, etc.) and provide adequate ventilation necessary to prevent overheating.

WARNING

Fill all gearboxes with the recommended grades and quantities of lubricant; (refer to section 5.3). Beware of over/under filling the gearbox as this could cause the pump to over heat and severe mechanical damage to occur.

WARNING

Before operating the pump, be sure that it and all parts of the system to which it is connected are clean and free from debris and that all valves in the suction and discharge pipelines are fully opened. Ensure that all piping connecting to the pump is fully supported and correctly aligned with its relevant connections. Misalignment and/or excess loads will cause severe pump damage. This could result in unexpected mechanical contact in the pump head and has the potential to be a source of ignition.

WARNING

Be sure that pump rotation is correct for the desired direction of flow; (refer to section 3.1).

WARNING

Do not install the pump into a system where it will run dry (i.e. without a supply of pumped media) unless it is equipped with a flushed shaft seal arrangement complete with a fully operational flushing system. Mechanical seals require a thin fluid film to lubricate the seal faces. Dry running will cause excessive heat and seal failure

WARNING

Pressure gauges/sensors are recommended, next to the pump suction and discharge connections to monitor pressures.



Caution must be taken when lifting the pump. Suitable lifting devices should be used as appropriate. Lifting eyes installed on the pump must only be used to lift the pump, not pump with drive and/or baseplate. If pump is baseplate mounted, the base plate must be used for all lifting purposes. If slings are used for lifting, they must be safely and securely attached. For weights of bare shaft pumps refer to section 5.5.



DO NOT attempt any maintenance or disassembly of the pump or pump unit without first ensuring that:

- The pump is fully isolated from the power source (electric, hydraulic, pneumatic).
- The pumping chamber, pneumatic relief valve and any shaft seal support system are depressurised and purged.
- Any temperature control devices (jackets, heat-tracing, etc.) are fully isolated, that they are depressurised and purged, and components are allowed to reach a safe handling temperature.



DO NOT attempt to dismantle a pressure relief valve which has not had the spring pressure relieved, is still connected to a pressurised gas/air supply or is mounted on a pump that is operating. Serious personal injury or death and/or pump damage may occur.



DO NOT loosen or undo the front cover, any connections to the pump, shaft seal housings, temperature control devices, or other components, until sure that such action will not allow the unsafe escape of any pressurised media.



Pumps and/or drives can produce sound power levels exceeding 85-dB (A) under certain operating conditions. When necessary, personal protection against noise must be taken.



Avoid any contact with hot parts of pumps and/or drives, which may cause injury. Certain operating conditions, temperature control devices (jackets, heat-tracing, etc.), bad installation, or poor maintenance can all promote high temperatures on pumps and/or drives.

WARNING

When cleaning, either manually or by CIP method, the operator must ensure that a suitable procedure is used in accordance with the system requirements. During a CIP cleaning cycle, a pump differential pressure of between 2 and 3 bar (30 to 45 psi) is recommended to ensure suitable velocities are reached within the pump head. The exterior of the pump should be cleaned periodically.



Surface temperature of pump is also dependent on the temperature of pumped medium.

1.1 Risk assessment relating to the use of Wright Flow Technologies Limited.
RTP rotary lobe pumps and pump units in potentially explosive atmospheres.

Note:- For a feature to be suitable for an application, The feature must be fit for its designated purpose and also suitable for the environment where it is to be installed.

Source Of Hazards	Potential Hazards	Frequency Of Hazards	Recommended Measures
Unvented cavities	Build up of explosive gas	Very Rare	Ensure that pump is totally filled. Consider mounting ports vertically. See Chapter 1.0
Rotorcase / Rotors / Front Cover	Unintended mechanical contact	Rare	Ensure that operating pressures are not exceeded. Ensure that sufficient NPSH to prevent cavitation. See Chapter 1.0 / 3.3.1 Service plan.
Pump external surfaces	excess temperature. Electrostatic charging	Rare	User must ensure temperature limits. Do not overfill gearboxes with lubricant. Provide a ground contact for pump. See Chapter 1.0 / Service plan.
Cover 'O' ring	Pump liquid leakage. Build up of explosive gas.	Very Rare	Check selection of elastomers are suitable for application. Ensure cover retaining nuts are tight. Service plan.
Pump casing / cover	Pump liquid leakage. Build up of explosive gas.	Very Rare	Stainless steel, Corrosion resistant.
Shaft seals	excess temperature. Unintended mechanical contact. Leakage. Build up of explosive gas.	Rare	Selection of seal system must be suitable for application. See Chapter 1.0 / 4.3. Service plan. Seals must never run dry.
Auxiliary system for shaft sealing	Pump liquid leakage. Build up of explosive gas.	Rare	Selection of auxiliary seal system must be suitable for application. Seals must never run dry.
Rotation direction test	Excess temperature	Very Rare	If flushed seals are installed ensure that flush is applied to seal assemblies. Only allow pump to run for minimum period - just a few seconds.
Closed valve condition	Excess Temperature. Excess Pressure. Mechanical contact.	Rare	Can cause excessive pressure, heat and mechanical contact. See Chapter 1.0
Shaft	Random induced current	Very Rare	Provide a ground contact for pump. See Chapter 1.0.
Mechanical shaft coupling (Torque Protection)	Temperature from friction Sparks from break up of shear pins. Electrostatic charging	Rare	Coupling selection must suit application. See Chapter 1.0.
Mechanical shaft coupling (standard)	Break up of spider. Unintended mechanical contact. Electrostatic charging	Rare	Coupling selection must suit application. Service plan. See Chapter 1.0.

2.0 Introduction.

2.1 General.

RTP™ rotary lobe pump is manufactured by Wright Flow Technologies Limited a unit of the IDEX Corporation.

This manual includes all the necessary information for RTP™ pumps and should be read prior to beginning installation, operation, or maintenance.

Should you require any additional information regarding the RTP™ pumps contact Wright Flow Technologies Limited or their local authorised distributor (refer to section 2.2).

When asking for assistance, please provide the pump model and serial number. This information can be obtained from the pump nameplate, which is located on the side of the pump gearbox cover, see fig 2. Should the nameplate be unreadable or missing, the pump serial number is also stamped on either side of the rotorcase, see fig 3.

If the system or product characteristics are to be changed from the original application for which the pump was selected, Wright Flow Technologies Limited or their authorised distributor should be consulted to ensure the pump is suitable for the new application.

2.2 Wright Flow Technologies Limited Distributors.

Wright Flow Technologies Limited distributes its products internationally via a network of authorised distributors. Throughout this manual where reference is made to Wright Flow Technologies Limited, service and assistance will also be provided by any Wright Flow Technologies Limited authorised distributor for RTP™ pumps.

2.3 Receipt and Storage.

Upon receipt of the pump, immediately examine it for any signs of visible damage. If any damage is noted, contact Wright Flow Technologies Limited or your Wright Flow Technologies Limited distributor and clearly mark upon the carriers paperwork that the goods have been received in a damaged condition, with a brief description of damage.

If the pump is not required for immediate installation then it should be stored in a clean, dry environment. It is recommended that storage temperature should be between –10°C and 40°C (14°F and 105°F).

2.4 Cleaning.

The RTP™ pump series is suitable for both manual cleaning and CIP (Cleaning In Place), refer to section 3.3.2.

The product seals are mounted directly behind the rotors and are designed and positioned to minimise product entrapment and maximise the effects of cleaning.

This strategic positioning of the product seals, combined with their ease of access provides an arrangement that can be more effectively cleaned by both manual and CIP procedures.

It is recommended that the exterior of the pump be cleaned periodically.

2.5 Pump Model Designation.

Fig 1 Designation of pump models

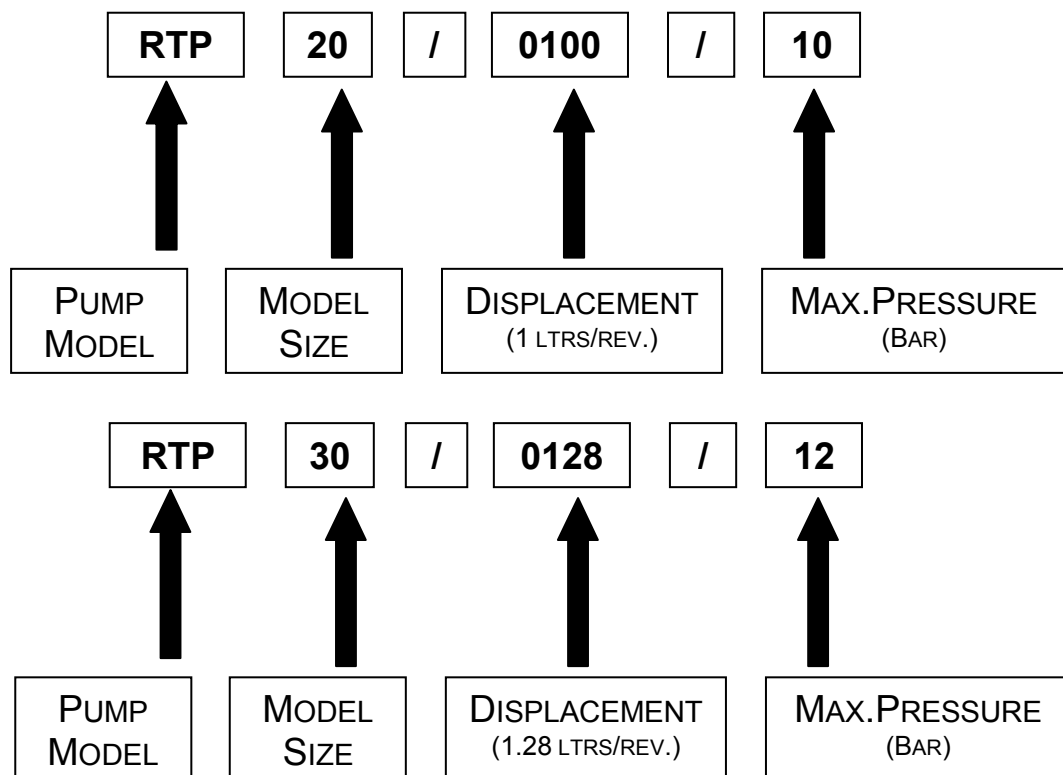

This information, together with the pump serial number, should be provided when requesting additional information on the pump or when ordering spare parts. The pump serial number is stamped on the pump nameplate and the rotorcase, (refer to section 2.6, figs 2 and 3). For the maximum operating pressures, temperatures and speeds refer to section 3.2.

2.5.1 ATEX Information

ATEX Pump Requirements

Please be aware that mechanical seals are a source of heat and must never be allowed to run dry. We would recommend provision be made to ensure that there is a flow of fluid around the pump seals at all times. If there is a risk of the supply being interrupted, we would recommend that the flush on the seals be fitted with a flow detection device. The surface temperature of the pump is dependent on the temperature of the pumped fluid and due account of this should be taken whilst undertaking your risk assessment of the installation. These pumps are rated to T3.

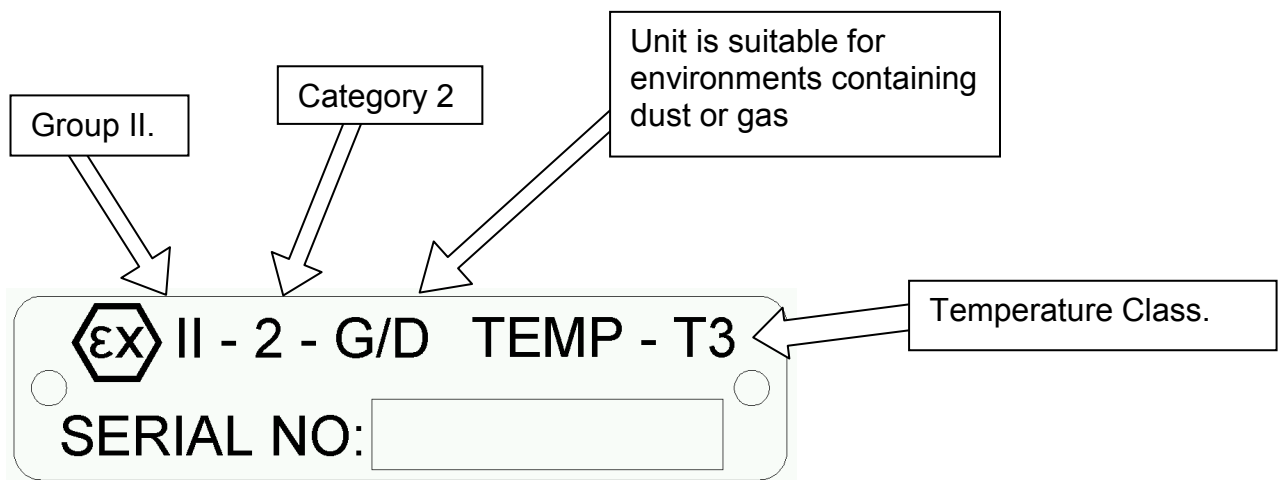

2.5.2 Equipment Groups & Categories

Equipment-groups (Annex I of the EC-Directive 94/9/EC)							
Group I (mines, mine gas and dust)		Group II (other explosive atmospheres gas/dust)					
Category M		Category 1		Category 2		Category 3	
1	2	G (gas) (Zone 0)	D (dust) (Zone 20)	G (gas) (Zone 1)	D (dust) (Zone 21)	G (gas) (Zone 2)	D (dust) (Zone 22)
for equipment providing a very high level of protection when endangered by an explosive atmosphere	for equipment providing a high level of protection when likely to be endangered by an explosive atmosphere	for equipment providing a very high level of protection when used in areas where an explosive atmosphere is very likely to occur		for equipment providing a high level of protection when used in areas where an explosive atmosphere is likely to occur		for equipment providing a normal level of protection when used in areas where an explosive atmosphere is less likely to occur	

2.6 Pump Model and Serial Number.

Should you require any information regarding your RTP™ rotary lobe pump contact Wright Flow Technologies Limited or your Wright Flow Technologies Limited distributor, providing the pump model and serial number as stated on the pump nameplate, see Fig 2, which is fixed to the pump gearbox cover. Should this be damaged or missing, the pump serial number is also stamped on opposite corners of the rotorcase, (see Fig 3).

Fig 2 Nameplate.

wright flow TECHNOLOGIES	IDEX SANITARY GROUP
Model:	
Serial No:	
Max. Pressure (Bar):	
Fill with lubricant as recommended Wright Flow Technologies Ltd Eastbourne, United Kingdom Phone: +44 (1323) 509211 Fax: +44 (1323) 507306	

Fig 3 Serial Number Location.

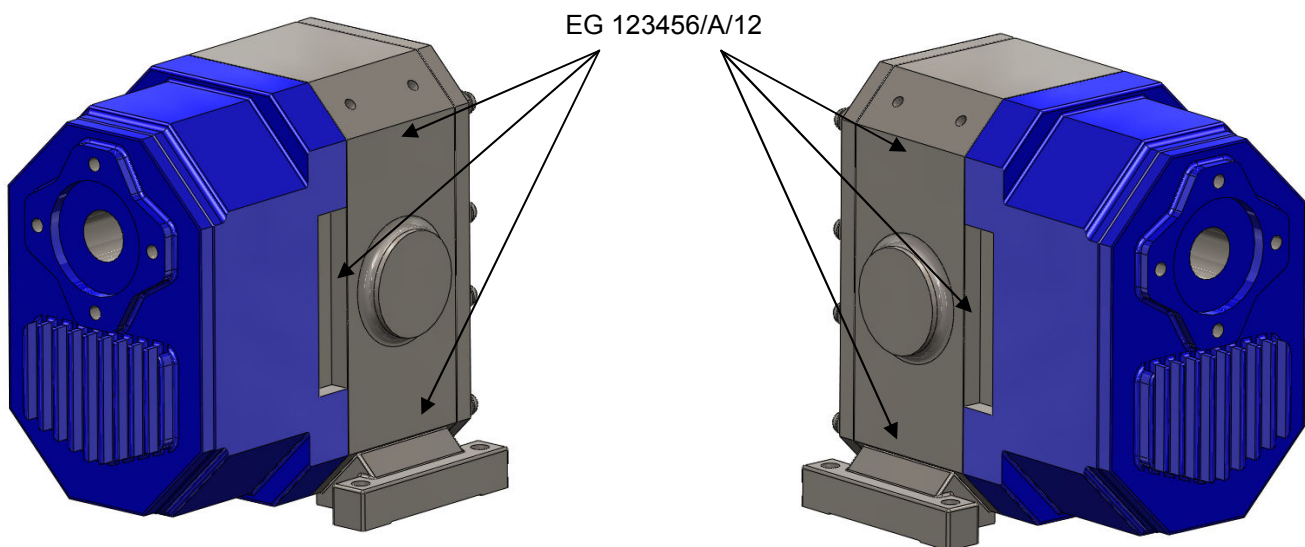

3.0 General.

3.1 RTP™ Pumping Principle.

The pumping action of the rotary lobe pump principle is generated by the contra-rotation of two pumping elements (rotors) within a chamber (rotorcase), Fig 4. The shaft assemblies comprise of, the shaft support bearings and the timing gears. The gears transfer the energy from the drive shaft to the driven shaft, synchronising the rotors such that they rotate without contact with each other.

As the rotors pass the suction port, ('A'), the cavity increases creating a pressure decrease, which induces the pumped medium to flow into the rotorcase.

The pumped medium is carried around the rotorcase by the rotors, ('B') and ('C'), to the discharge side of the pump, ('D'). Here the cavity decreases and the pumped medium is discharged from the rotorcase, ('E').

Fig 4 Rotary Lobe Pump Principle.

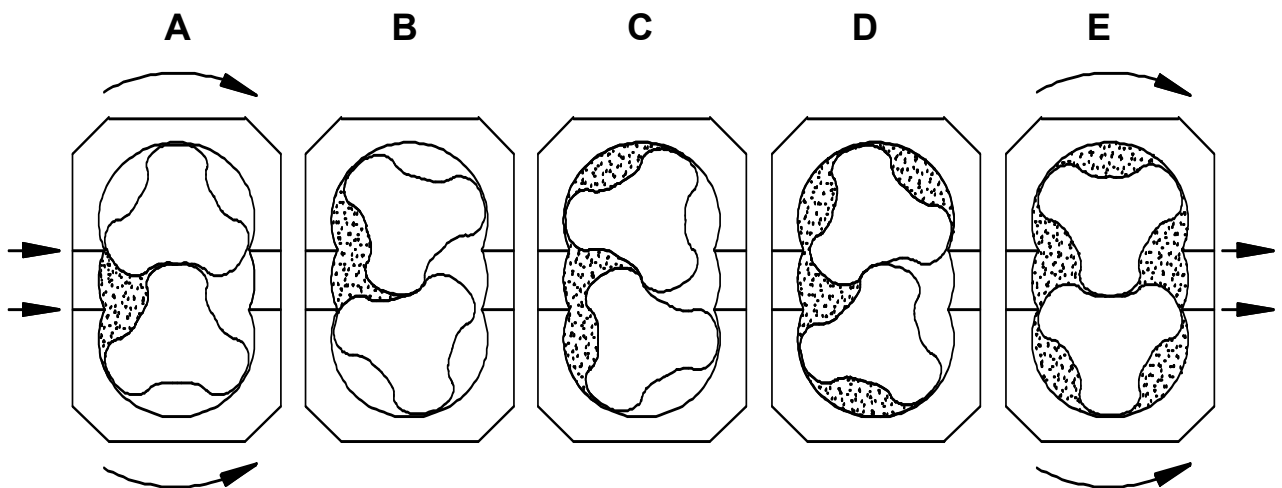

3.2 RTP™ Operating Parameters.

Fig 5 Operating Parameters

RTP20

Theoretical Displacement			Nominal Connection Size		Max Diff. Pressure		Maximum Speed	Max Temp	Max Temp
Litre/ rev	Imp.gal /100 rev	US gal / 100 rev	mm	inches	bar	psi	rev/min	C°	F °
1.00	21.9	26.4	50 or 75	2 or 3	10	145	1000	110	230

RTP30

Theoretical Displacement			Nominal Connection Size		Max Diff. Pressure		Maximum Speed	Max Temp	Max Temp
Litre/ rev	Imp.gal /100 rev	US gal / 100 rev	mm	inches	bar	psi	rev/min	C°	F °
1.28	28.2	33.8	75 or 100	3 or 4	12	175	1000	150	300

The maximum pressure and speed operating parameters are given above. In practice these may be limited due to the nature of the product to be pumped and/or design of the system in which the pump is to be installed. Consult Wright Flow Technologies Limited or your Wright Flow Technologies Limited distributor for assistance.

WARNING

If the system or product characteristics are to be changed from the original application for which the pump was selected, Wright Flow Technologies Limited or their authorised distributor should be consulted to ensure the pump is suitable for the new application.

The pump should not be subjected to sudden temperature changes to avoid the risk of damage from sudden expansion/contraction of components. Care should be taken when selecting pumps for handling liquids containing abrasive particles as these may cause wear of pump head components. For advice or assistance contact Wright Flow Technologies Limited or your Wright Flow Technologies Limited distributor.

3.3 System Design and Installation.

When incorporating any pump into a system it is considered good practice to minimize piping runs and the number of pipe fittings (tees, unions, bends etc.) and restrictions. Particular care should be taken in designing the suction line, which should be as short and straight as possible with a minimum of pipe fittings to minimise restricting product flow to the pump. The following should be considered at the design stage of any system



Be sure ample room is provided around the pump to allow for:

- Access to the pump and drive for routine inspection and maintenance, i.e. to remove pump front cover and rotors.
- Ventilation of the drive to prevent over heating.



The exterior of the pump unit may exceed 68°C (154°F),
Appropriate measures must be taken to warn or protect operators.

WARNING

The pump must not be used to support piping. All piping to and from the pump unit must be independently supported. Failure to observe this may distort the pump head components or assembly and cause serious consequential damage to the pump.

Valves should be provided adjacent to the pump suction and discharge connections to allow the pump to be isolated from the system for routine inspection and maintenance.



Rotary lobe pumps are of the positive displacement type and therefore an overload protection device must be provided. This can take the form of:

- An in-line pressure relief system, i.e. external to the pump.
- Incorporation of a torque-limiting device in the drive system.

WARNING

It is recommended that all piping and associated equipment from the tank to the discharge point is thoroughly cleaned before installation of the pump to avoid the possibility of debris entering the pump and causing damage.

WARNING

Pressure gauges should be installed adjacent to the pump suction and discharge connections such that system pressures can be monitored. These gauges will provide a clear indication of changes in operating conditions and where a relief valve is incorporated in the system, will be necessary for setting and checking the functioning of the valve.

WARNING

It is imperative that the suction condition at the pump inlet meets the Net Positive Suction Head required (NPSHr) by the pump. Failure to observe this could cause cavitation, resulting in noisy operation, reduction in flow rate and mechanical damage to the pump and associated equipment.

WARNING

The Net Positive Suction Head available (NPSHa) from the system must always exceed the Net Positive Suction Head required (NPSHr) by the pump

Observing the following general guidelines should ensure the best possible suction condition is created.

- Suction piping is at least the same diameter as the pump connections.
- The length of suction piping is kept to the absolute minimum.
- The minimum number of bends, tees and pipework restrictions are used.
- Calculations to determine system NPSHa are carried out for the worst condition see below.

Should advice on pump or system NPSH characteristics be required contact the factory or their authorised distributor.

Fig 6

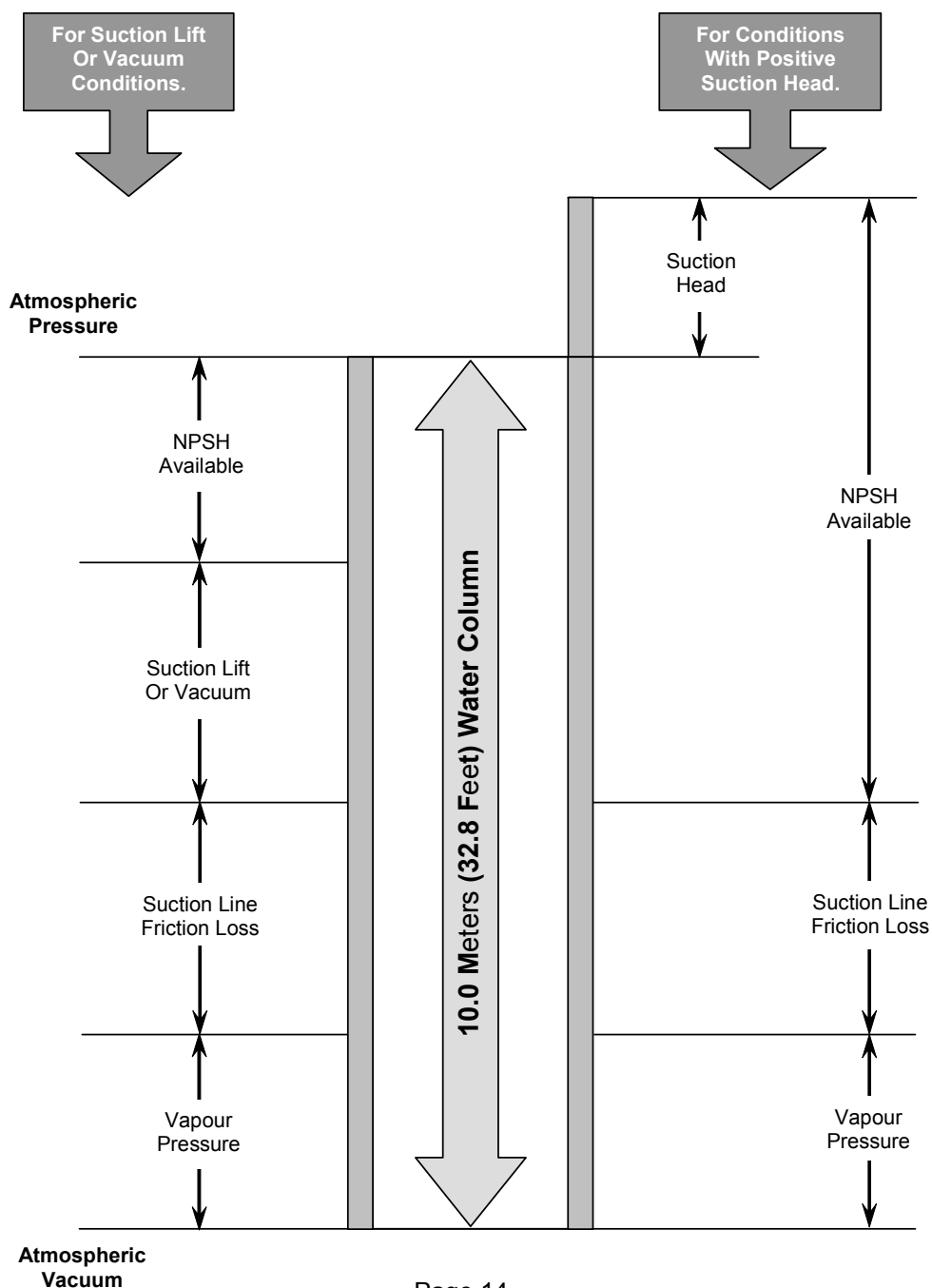

Where motor mounted options are to be installed follow the manufactures recommended guidelines. However, when installing a pump complete with base and drive the following guidelines must be observed:

- The preferred drive arrangement for any rotary lobe pump is in-line direct coupled.
- Flexible couplings must always be incorporated and correctly aligned within the limits recommended by the coupling manufacturer. To check coupling alignment rotate the shaft by at least one full revolution and ensure that the shaft rotates smoothly.



Couplings of a non-flexible design must never be used.

- Couplings must always be enclosed in a suitable guard to prevent contact with rotating parts that could result in personal injury. Guards should be of suitable material, and of sufficiently rigid design to prevent contact with rotating parts under normal operating conditions.



- When installing pump sets in flammable or explosive environments, or for handling flammable or explosive materials, special consideration must be given not only to the safety aspects of the drive unit enclosure but also to the materials used for both the coupling and the guard to eliminate the risk of explosion.



- Baseplates must be secured to a flat level surface such that distortion and misalignment are avoided. **Once baseplates are fastened in position the drive alignment must be re-checked.**



- When using electric motor drives, ensure that the electrical supply is compatible with the drive and controls and that the method of wiring is correct for the type of starting required by the motor i.e. Direct On Line, or other similar method. Ensure all components are correctly grounded.

3.3.2 Installation with CIP Systems.

The RTP™ range has been designed to be effectively cleaned by the CIP procedures recommended for in place cleaning of process plant. To assist in maximising the effectiveness of cleaning within the pump head it is recommended that during the cleaning cycle a flow rate equivalent to a velocity of 1.5 metres per second; in a pipe of equal diameter to the rotor case connections is achieved. With a differential pressure of 2 to 3 bar (30 to 45 psi) being developed across the pump head

For applications where maximum drainage of the pump head is required, for example in the handling of 'Agri-Foodstuffs' and / or where CIP is employed, the pump ideally should be mounted with the rotor case connections in the vertical orientation. A procedure must be determined to ensure that the pump is effectively cleaned. It is recommended that this cycle would typically include a combination of some or all of the following: Acidic or Caustic based Detergents, 'Sanitisers', Disinfectants and Water rinses. These must be appropriate to both the products being handled and the materials of construction of the pump.

3.4 Start Up Procedure.

- WARNING** - Check that all piping and associated equipment are clean and free from debris and that all pipe connections are secure and leak free.
- WARNING** - For pumps installed with flushed product seals check that all auxiliary services are in place and connected and provide sufficient flow and pressure for flushing purposes, refer to product seal section 4.3.
- WARNING** - Refer to section 5.3 for lubricant capacities and grades. As standard the pump is shipped with grease lubricant unless otherwise specified. The oil filled pumps differ in gearbox construction where breather, drain plug and sight glasses are fitted.
- WARNING** - If an external relief valve is incorporated in the system check that it is set correctly. For start up purposes it is considered good practice to set the relief valve lower than the system design pressure. On completion of start up the relief valve should be reset to the required setting for the application. The required setting should never exceed the lower of either the pumps maximum pressure rating or the system design pressure. For setting integral relief valves, refer to sections 3.8.
- WARNING** - Ensure both suction and discharge valves are fully open, and pipework is free from all obstructions. RTP™ pumps are of the positive displacement type and should therefore never be operated against a closed valve as this would result in pressure overload, resulting in damage to the pump and possibly the system.
- WARNING** - Ensure rotation of the drive shaft is correct for the direction of flow required, see Fig 7.

Fig 7 Direction of Rotation

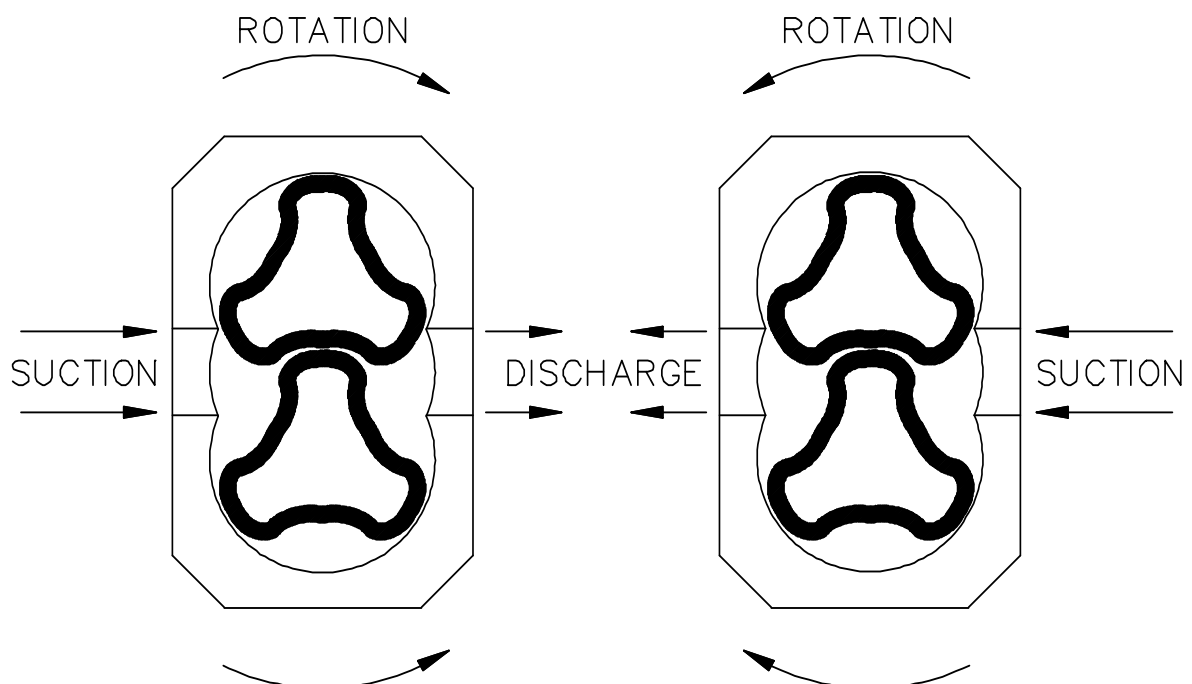

WARNING

- Ensure product is available in the tank before starting pump. This is very important for pumps installed with un-flushed product seals, as these sealing arrangements must never be allowed to run dry.
- Before beginning operation it is considered good practice to momentarily start/stop the pump to check the direction of rotation and ensure that the pump is free of obstructions. Once this has been carried out, begin operation keeping a visual check on suction and discharge pressure gauges and monitor pump temperature and power absorbed where possible.

3.5 Shutdown Procedure.



When shutting the pump down close both the suction and discharge valves and ensure that the necessary safety precautions are taken:

- The prime mover power source has been isolated.
- If installed, flushed product seal auxiliary services have been isolated and depressurised.
- Pump head and piping have been drained and purged.

3.6 Routine Maintenance.

- RTP™ pumps are shipped fully lubricated with a lithium based extreme pressure lubricant suitable for sealed for life units.
- For lubricant capacities refer to section 5.3.

3.7 Heating and Cooling Devices

See Fig 8.

The RTP™ model can be supplied with a jacketed front cover and rotorcase with ports for circulation of a heating/cooling media. The jacketed front cover and rotorcase heating and cooling ports are strategically positioned such that the required thermal effect acts on the pumping chamber and product seal area.



The pressure rating of the RTP™ jacketed front cover and rotorcase heating/cooling ports is 3.5 bar g (50 psi) and should not be exceeded without consulting Wright Flow Technologies Limited or your local Wright Flow Technologies Limited distributor.

Heating/cooling of the pump head is used to maintain, rather than increase/decrease the temperature of the pumped media and should be used as part of a complete system where suction and discharge lines and vessels are also heated/cooled.

Where heating/cooling devices are employed, the heating/cooling media should be circulated 15-20 minutes prior to pump start-up and should be allowed to continue for a similar period of time after the pump has been shutdown. Where a CIP cycle is employed as part of the process, the heating/cooling media should continue to be circulated during the cleaning cycle.

Fig 8 Dimensions for Heating/Cooling.

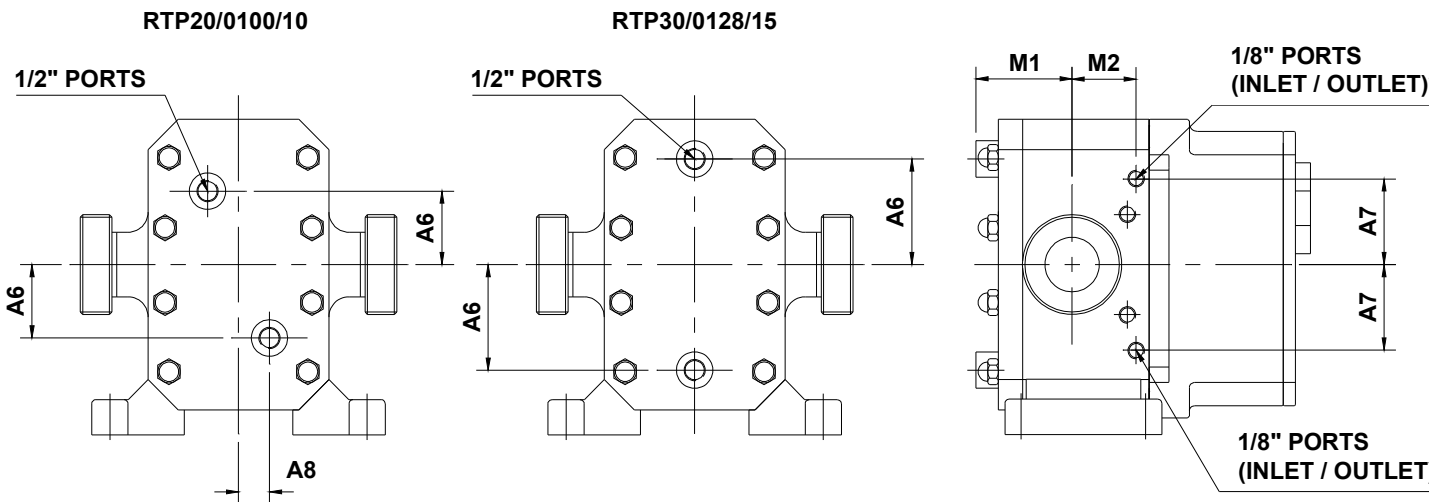

Dimensions in Millimeters

	A6	M1	A7	M2	A8
RTP20/0100/10	80	79	N/A	N/A	45
RTP30/0128/12	108	86	82.5	51	N/A

Dimensions in Inches

	A6	M1	A7	M2	M2
RTP20/0100/10	3.14	3.11	N/A	N/A	1.77
RTP30/0128/12	4.25	3.39	3.25	2.01	N/A

- * BSP Ports fitted as standard.
- * N/A = Option not available.

Note: For all other dimensions see section 5.5.

3.8 Integral Pressure Relief Valve.

Integral pressure relief valves are normally used to protect the pump from the effects of increases in system pressure caused, for example, by a restricted or closed discharge line. In response to a pressure increase the valve opens and internally circulates the pumped media within the pump chamber.

When the valve opens, because the volume of fluid circulating is relatively small, the temperature of the fluid in the pump chamber may rise if the pump continues to operate for an extended period. In severe cases this may result in temperatures in excess of the pumps operating limits or vaporisation of the fluid. For these reasons when the valve is activated the cause of the system pressure increase should be eliminated as continuous operation of the pump with the valve open is not recommended and may cause severe damage to the pump.

WARNING

If the pump on which the valve is installed is to be installed in either a pressurised system or one incorporating a vessel under vacuum, the application of the valve should be referred to Wright Flow Technologies Limited or their authorised distributor. In addition where the pump is mounted onto a mobile unit with drive, it is recommended that an integral pressure relief valve be installed.

WARNING

Note: Care should be taken not to exceed the either the pumps maximum pressure rating or the system design pressure.

The spring housing component including spring, stem and valve; are manufactured as complete units and available in 7, 10 and 12 bar options. This must be specified at time of order. If further adjustment is required to the assemblies consult Wright Flow Technologies Limited or your local Wright Flow Technologies Limited distributor.

Fig 9 Pre-Set Relief Valve.

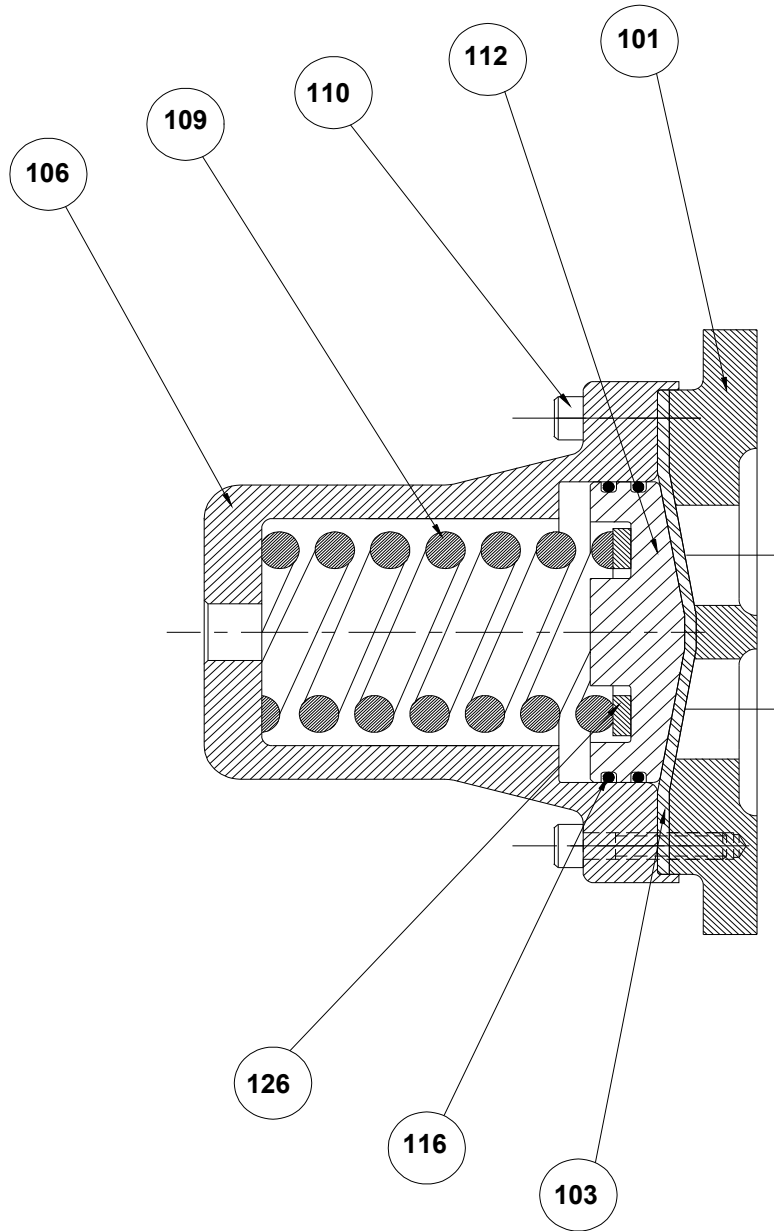

ITEM NUMBER	DESCRIPTION
101	RV FRONT COVER
103	DIAPHRAGM (PTFE FACE TO THE PRODUCT)
106	SPRING HOUSING
109	SPRING
110	SCREW
112	VALVE HEAD
116	O-RING
126	SPACER (IF REQUIRED)

DANGER



Under no circumstances should any attempt be made to dismantle a pressure relief valve which has not had the spring pressure relieved (where applicable) or is mounted on a pump that is operating. Serious personal injury or pump damage may occur.

4.0 RTP™ Pump Dismantling and Assembly.



Before undertaking any work on the pump the Shutdown Procedure should be followed in section 3.5, and site safety practices must be observed.



While dismantling or assembling the pump it is essential to ensure that the pump and/or components are secured to provide adequate stability.



Large pump components or assemblies should be lifted using suitable devices. Use threaded holes for attaching lifting eyes where appropriate.

During dismantling or before assembly all components should be inspected for fit, wear, and damage. If worn or damaged the components should be replaced before re-assembly.

The position of all parts should be identified as they are removed to ensure they are reinstalled in the same position.

Lipseals and o-rings are incorporated within the assembly. Regular inspection and correct maintenance of these items will ensure that the lubrication is sustained and the pump maximum working life is achieved. To ensure this, it is extremely important that care is taken when removing and installing new o-rings and lipseals. When removing and replacing lipseals ensure that the location bore for the outside diameter and the seat for the back of the lipseal is not damaged as this may create a leakage path.

When removing lipseals or o-rings care should be taken to avoid cutting or tearing the sealing faces as they pass over splines, threads or other potentially sharp or abrasive edges. All lipseals and o-rings should be carefully examined and if damaged in any way, replaced on assembly.

All o-rings and sealing lips of lipseals should be lightly lubricated with a suitable lubricant (silicon grease, etc.) before installing.

Prior to assembly, ensure all parts are clean and free from burrs or damage. Where a vice is to be used, it should have protective jaws to avoid damage to components. Do not apply undue force to install or position components.

WARNING

All fasteners are required to be tightened to the required torque setting during assembly, refer to section 5.2.

Bearing cones may be pressed into position providing the proper equipment and procedures are employed to prevent component damage.

WARNING

Under no circumstances should bearing cones or cups be hammered into position.

For torque settings of fasteners and shaft rolling torque, see section 5.2.

4.1 Disassembly.

4.1.1 Front Cover and Rotor Removal

See Fig 10.



- Follow recommended Shutdown Procedure, referring to section 3.5.
- Gradually loosen front cover retaining nuts (36). Care should be taken as residual product and pressure may still be present in the pump head. As the dome nuts are loosened this will vent to atmosphere.
- Remove dome nuts (36).
- Remove front cover (38), using lever slots where necessary, continue and remove the front cover o-ring (39) from rotorcase (40).
- Remove rotor retainers (35) using socket (58) provided.

WARNING

Note: The socket (58) should always be used. The use of other tools may damage the retainer.

- Remove retainer O-ring (34).
- Remove rotors (41) from shafts (9 and 10 – not shown), taking care not to damage the product seal components. Where viscous products are employed, a tool is available utilising the three M6 tapped holes, to aid in the removal of the rotors (41). Contact Wright Flow Technologies Limited or an authorised distributor for details.
- Remove o-ring (25 – not shown) from shafts (9 and 10 – not shown).
- Remove product seals, refer to section 4.3.

Fig 10 Front Cover & Rotor Removal

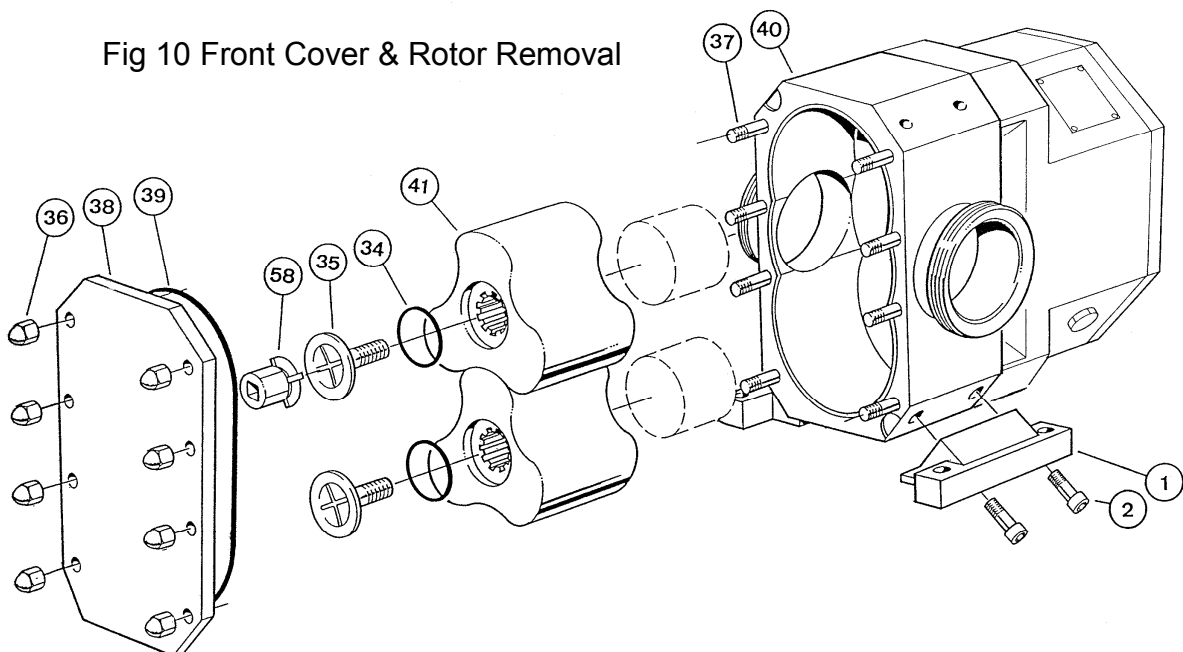

4.1.2 Gearbox Dismantling (After Completing 4.1.1).

The following procedures assume that pump has been removed from the base-plate and that the product seals have been removed (see section 4.3).

- Remove drain plug (5) and breather (21). Drain lubricant into suitable container and retain if later inspection is required.
- Remove retaining screws (74), and remove the endplate (70) from the gearbox (16) utilising the retaining screws (74) in the jacking points provided, see fig 12. The endplate is located on dowels (60) and is sealed by the o-ring (3), see fig 11.
- Remove the cups of the rear bearing (19, see fig 5.6) from the endplate (70).
- Remove the bearing pre-load shims (73, see fig 5.6). **The shims (73, see fig 5.6) may be different for each assembly and therefore should be kept in their respective positions.**
- Remove rear lipseal (11, not shown).

Fig 11 Endplate Removal.

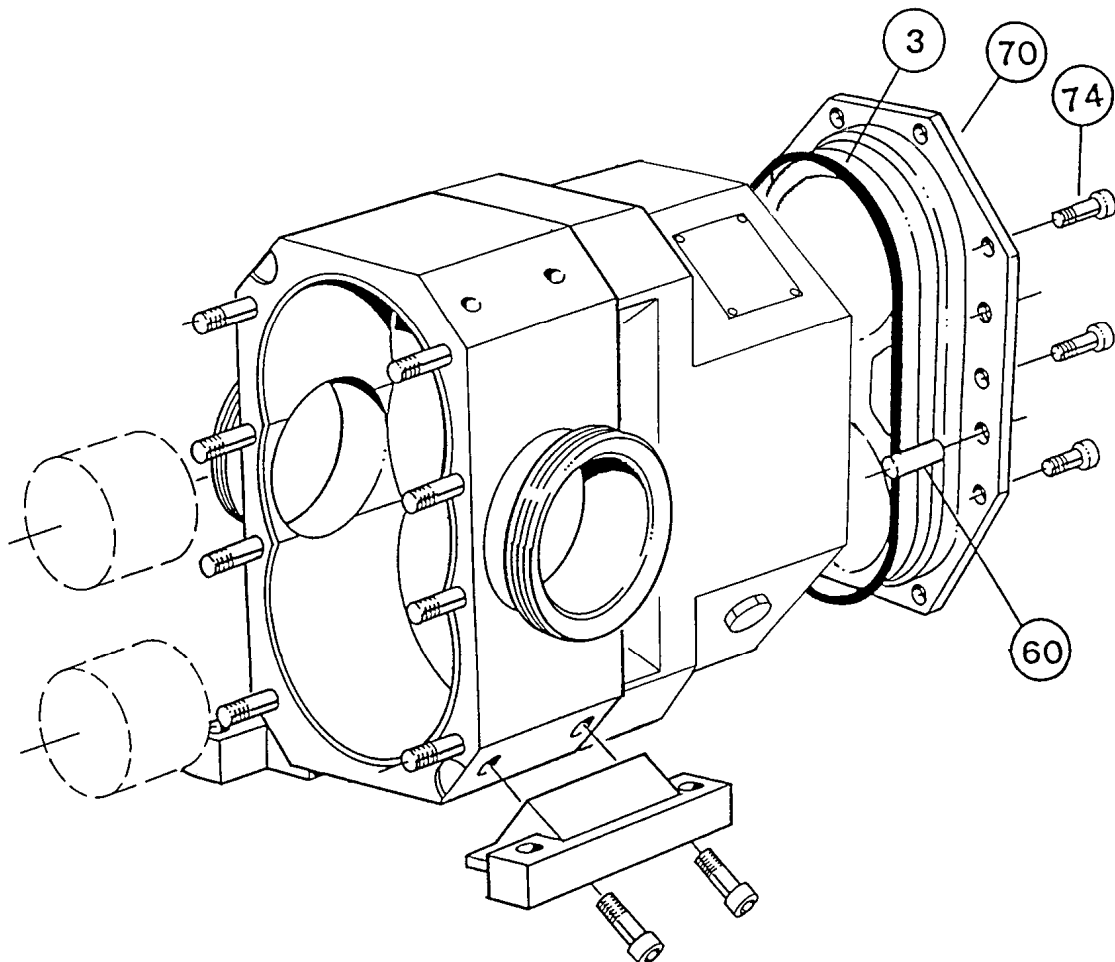

- Remove shaft assemblies from the gearbox (16, see fig 5.6). Shaft assemblies will be complete with gears (14), and bearings (24 and 19) – see fig 13.
- Remove lipseals (17) from the gearbox (16).
- Disassemble gearbox (16) from rotorcase (40) by removing the retaining screw (7). Utilising the retaining screws (7) in the jacking points on the gearbox; the gearbox (16) and rotorcase (40) can be separated, see fig 12.
- Remove bearing cup (24) from the gearbox (16).

Fig 12 Gearbox and Endplate Jacking Points.

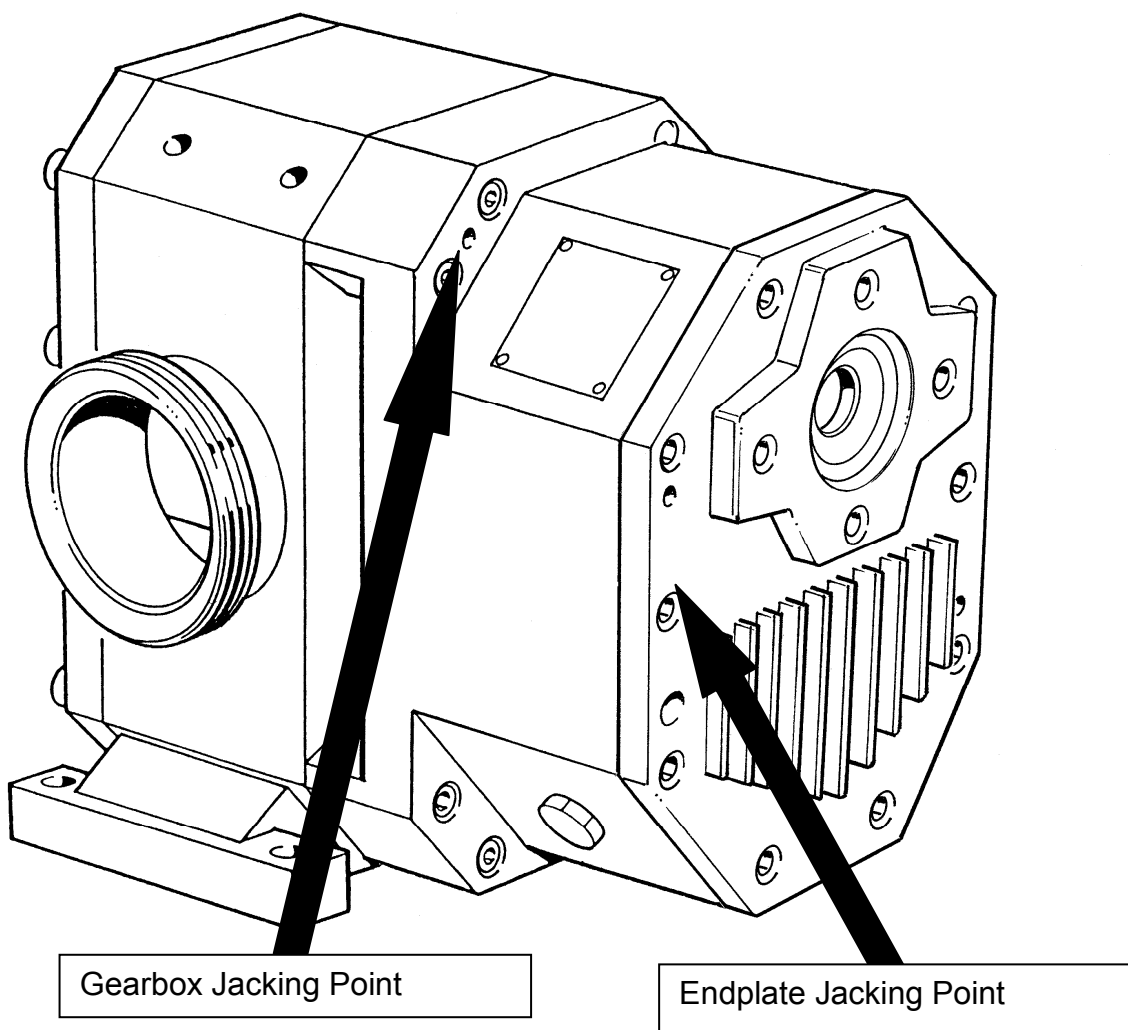

4.1.3 Shaft Disassembly (RTP30 Shown).

- Remove the rear bearing assembly (19).
- Remove the timing gear screws (23).
- Remove the timing gear (14) and locating dowel (80).
- Remove o-rings (26) from the rear of the shaft (9 or 10).
- Remove o-rings (25) from the front of the shafts (9 or 10).
- Remove front bearing assembly (24).

Fig 13 Bearing & Timing Gear Removal.

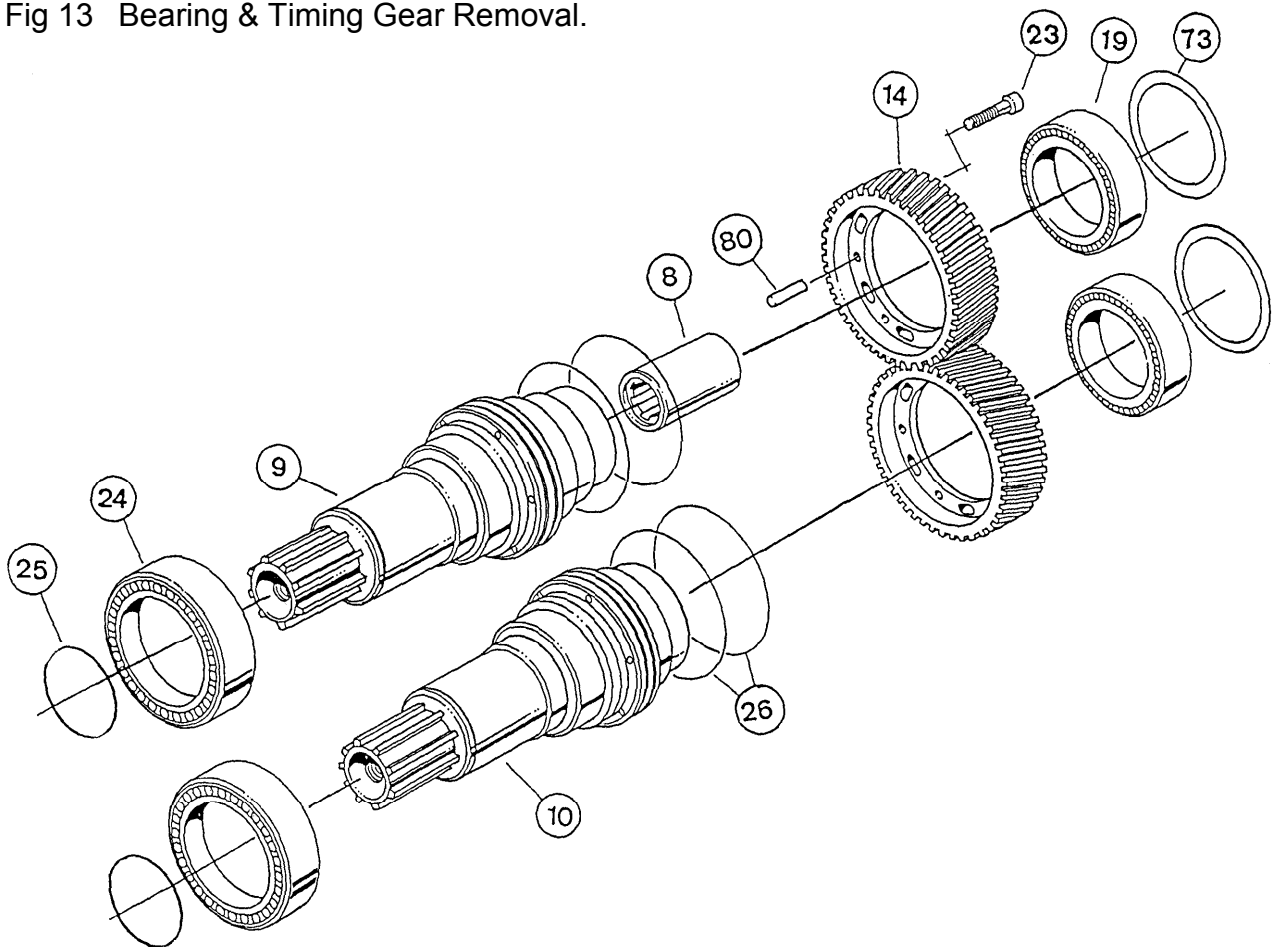

Note: Right hand helix for drive shaft gear (stamped D), left hand helix for driven shaft gear (stamped L). When ordering spare timing gears it is essential to purchase and install these as a pair.

4.2 Assembly.

4.2.1 Gearbox & Rotorcase Assembly, See Fig 14.

- Install front bearing cups (24 not shown).

WARNING

Do not install the front lip seals (17) until the bearing pre-load has been set. The lips may give a false rolling torque reading as well as increasing the risk of damage during assembly.

- Install rotorcase (40) to gearbox (16) and secure using cap screws (7).
- Install drain plug (5) , where required in required position in gearbox cover (16).
- If not already installed, mount feet (1) to rotorcase (40) in the required positions using cap screws (2). Install the seal sleeve (if required) see section 4.3.

Fig 14 Gearbox & Rotorcase Assembly.

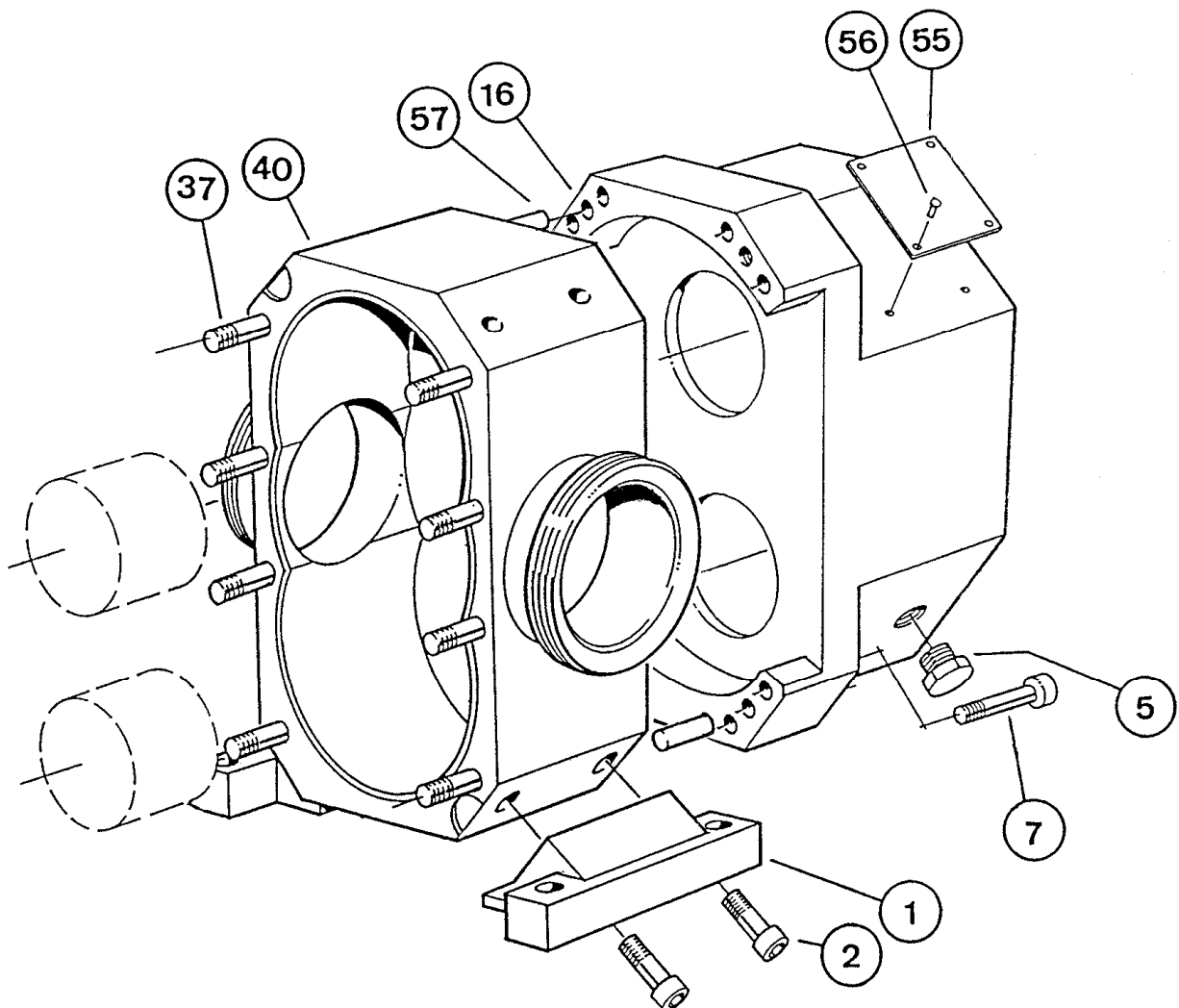

4.2.2 Shaft Assembly – RTP20

- Install front bearing (24) to shaft (9 or 10).
- Install o-rings (26 and 25), to shafts (9 or 10) in the appropriate grooves. Lightly lubricate all o-rings with a compatible lubricant.
- Install the gear (14) over the o-rings (26) and secure with retaining bolts (23). It is recommended that the screws be aligned at the centre of the slots provided to give an equal amount of adjustment in either direction. **They should also not be tightened to the correct torque at this point, as adjustment to the timing may still be required.**
- place a nominal amount (0.05 mm) of shim (73) under the rear bearing cups
- Install rear bearing (19).

Fig 15 Shaft Assembly.

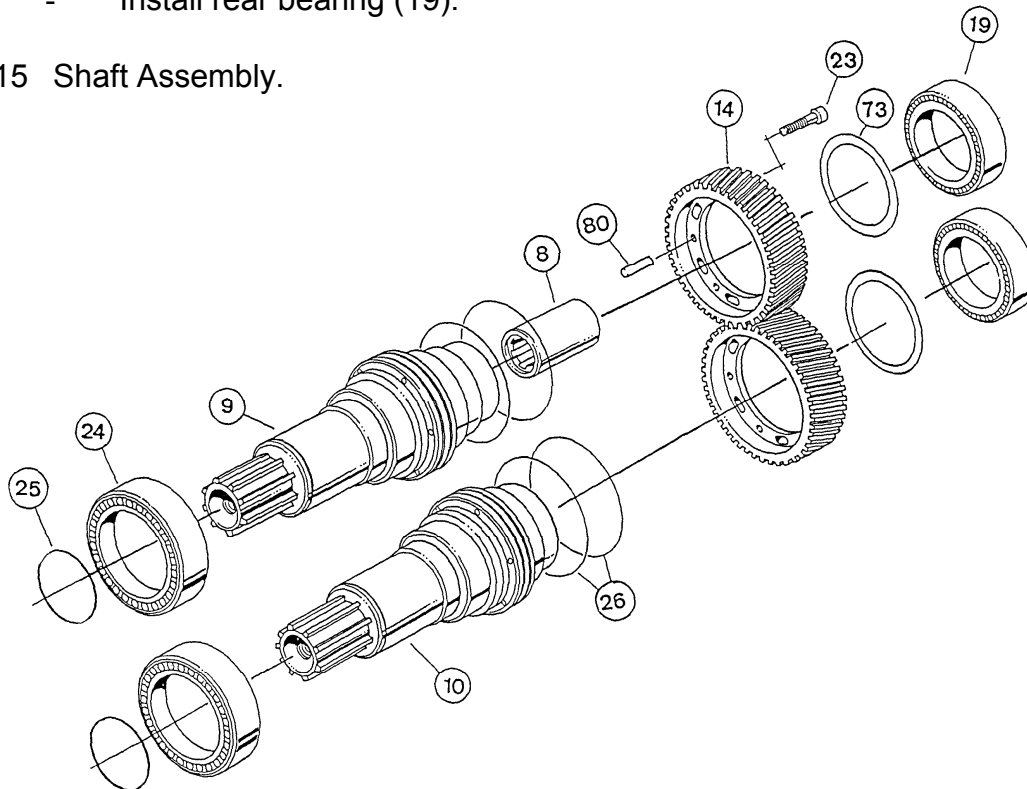

- Install the shaft assemblies into the gearbox (16) so that the cone and cup halves of the front bearing (24) are now one unit.
- Assemble the endplate by installing o-ring (3) **Do not install the rear lip seal (11) until the bearing pre-load has been set. The lips may give a false rolling torque reading as well as increasing the risk of damage during assembly.**
- Install endplate assembly onto the gearbox (16) locating on dowel (60).

WARNING

4.2.3 Shaft Assembly – RTP30

- Install front bearing (24) to shaft (9 or 10).
- Install o-rings (26 and 25), to shafts (9 or 10) in the appropriate grooves. Lightly lubricate all o-rings with a compatible lubricant.
- Install the gear (14) over the o-rings (26) and secure with retaining bolts (23). It is recommended that the screws be aligned at the centre of the slots provided to give an equal amount of adjustment in either direction. **They should also not be tightened to the correct torque at this point, as adjustment to the timing may still be required.**
- Install rear bearing (19).

Fig 16 Shaft Assembly.

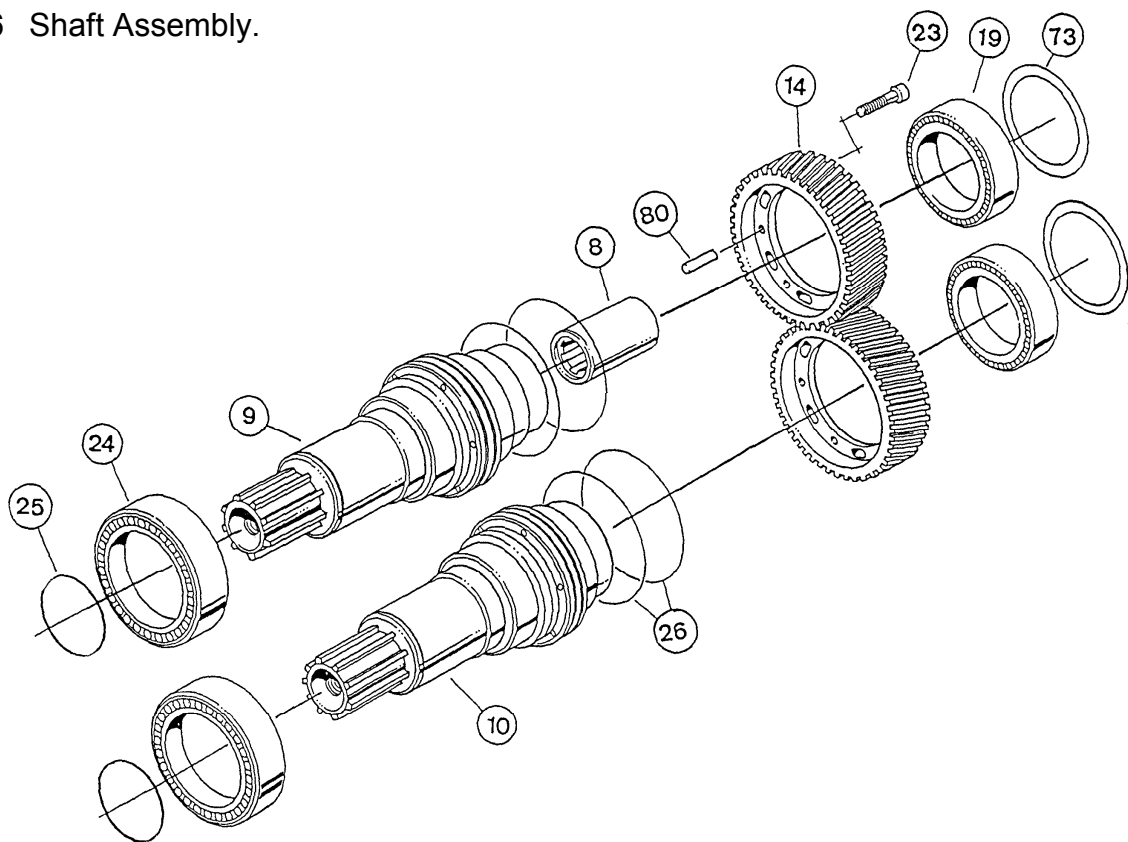

- Install the shaft assemblies into the gearbox (16) so that the cone and cup halves of the front bearing (24) are now one unit.
- Assemble the endplate by installing o-ring (3) and place a nominal amount (0.05 mm) of shim (73) under the rear bearing cups (19). **Do not install the rear lip seal (11) until the bearing pre-load has been set. The lips may give a false rolling torque reading as well as increasing the risk of damage during assembly.**
- Install endplate assembly onto the gearbox (16) locating on dowel (60).

WARNING

4.2.4 Timing.

- Rotate the shafts (9 and 10) so as to position the gaps made by the missing splines, in the vertically uppermost position, See Fig 17.

Fig 17 Aligning the missing splines.

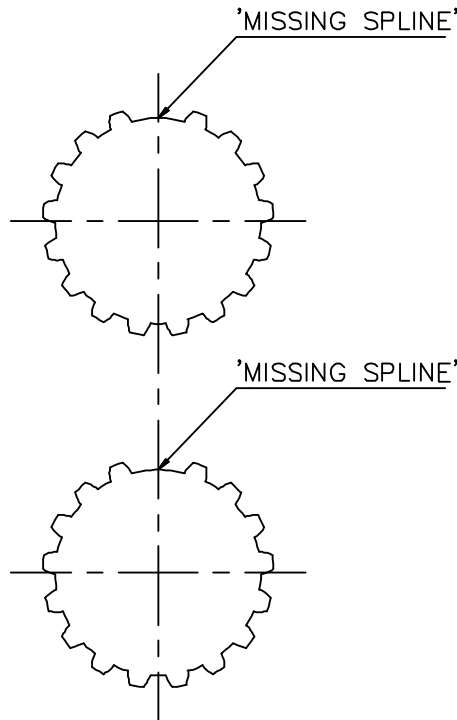

- Assemble the rotors (41), rotor retainers (35) and o-rings (34) onto the shafts (9 and 10).
- To achieve the correct timing clearance, rotate one shaft, whilst securing the other. The gear (14) will rotate on the lubricated o-rings until the correct mesh clearance is achieved. For mesh clearances refer to section 5.1.
- If the rotor clearances can not be achieved, then the rotor assembly will need to be dismantled and the shaft assembly removed from the gearbox. Rotate one tooth on the gear mesh, replace the shaft, and re-adjust the timing once more.
- Once the correct clearances have been achieved, tighten the gear retaining screw (23) to the correct torque see section 5.2, and mark the teeth at the mesh point, see Fig 18.
- **Recheck all clearances before moving on to the next stage.**

Fig 18 Aligning the mesh point.

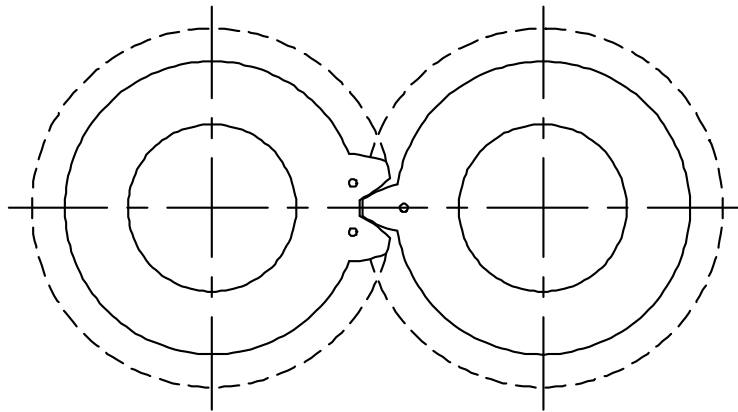

- Remove the shaft assemblies from the gearbox (16).
- Using the holes provided drill and ream both gear (14) and shaft (9 and 10) to suit $\text{Ø}6.0$ mm dowel (80), as shown in Fig 19. It is important to drill and ream the hole so that the dowel is positioned equally between the gears (14) and shafts (9 and 10).

Fig 19 Installing and positioning the timing dowel.

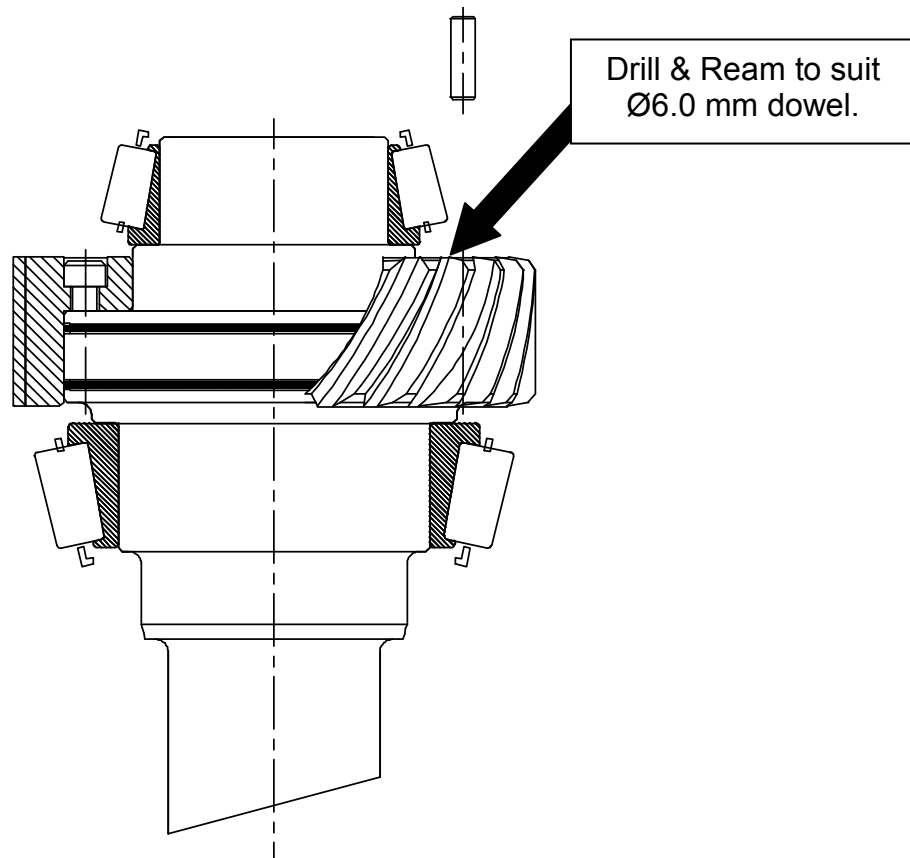

- Install the $\text{Ø}6.0$ mm dowel into the drilled and reamed hole; apply a suitable adhesive to ensure that the dowel stays in place.

4.2.5 Setting the rolling torque.

WARNING

It is important that the product seals and both front and rear lip seals are not installed until the bearing pre-load has been set and the clearances checked. The seals may give a false rolling torque reading as well as increasing the risk of damage during assembly.

- Re-install one of the shaft assemblies into the gearbox (16) and replace the endplate assembly, ensure that the retaining screws (74) are tightened to the correct torque, see section 5.2.
- Using a torque meter, check the rolling torque of each shaft assembly (separately) referring to section 5.2 for the correct settings. If necessary adjust the amount of shim (73) under the rear bearing cup (19). Either by adding shim (73) to increase the rolling torque, or by removing shim (73) to decrease the torque until the correct setting is achieved.
- Repeat steps detailed above for the remaining shaft assembly.
- Once the rolling torque has been set for both shaft assemblies. If the gearbox assembly is still installed to the rotorcase assembly, remove retaining screw (7). Utilising the jacking points on the gearbox and the screws (7), disassemble the gearbox assembly from the rotorcase assembly, see fig 12. The lip seals (17) can be installed into the gearbox (16) and the 'slinger' disc (62) where applicable, requires lubricating with a compatible lubricant before assembly onto the shaft. The lip seal (11) can also be installed into the endplate (70).

4.2.6 Rotor Clearances.

- Install rotors (41) onto shafts (9 and 10) in rotorcase (40), install retainer o-ring (34) into the bore of the rotor and secure with rotor retainer (35). Set to correct torque (see section 5.2) using socket tool (58).

Note: The retainer o-ring (34) seals the shaft/rotor spline and should not be re-used if cut, distorted or damaged in such a way as to impair its ability to form a seal. If in doubt a new o-ring should always be installed.

- Using a depth micrometer or similar device measure front clearance between the rotorcase and rotor front faces. With a feeler guage set or similar device measure the side and rear clearances.
- With rotors (41) installed, check all clearances, front (A), radial (C), rear (B) and mesh (D), against the Clearance Chart, refer to section 5.1. Remove rotors (41) and install product seals, refer to section 4.3, reassemble rotors (41) tightening to the correct torque.
- Install o-ring (39) into the rotorcase (40). Install front cover (38) to rotorcase (40), securing with dome nuts (36), tightening to correct torque, refer to section 5.2.

WARNING

4.3 Product Seal Fitting and Removal.

4.3.1 General Procedures for Installing Seals.

- Mechanical seals are precision-engineered assemblies incorporating finely lapped seal faces and seats. They must therefore be handled with care and will not give optimum performance unless installed carefully and according to instructions.
- Where mechanical seals are to be reused ensure that seal components are kept in their appropriate sets. **Do not mix old and new seal faces on the same seal.**
- Remove any sharp corners and burrs that may damage any elastomers such as o-rings or lip seals.
- Ensure that all seal component fitting bores and housings are thoroughly cleaned before installation.
- The seal faces and seats must be handled with care and cleaned thoroughly before installation.
- Ensure that seal faces are undamaged and the o-rings are not cut, swollen, or cracked.
- Lipseals and o-rings within the seal assemblies should be lightly lubricated with an elastomer compatible, food grade lubricant. Ensure there is not an excessive amount of lubricant especially around the seal face area. Lubrication points are available options, for more information contact Wright Flow Technologies Limited or your Wright Flow Technologies Limited distributor.
- When fitting PTFE encapsulated o-rings it is important to immerse them in hot water for several minutes to soften them.
- Ensure seal seats are mounted squarely.
- Ensure when installing seals with brittle faces such as silicon carbide that extra care is taken.
- Do not use any excessive force to install a mechanical seal. If it is difficult to position and assemble the seal then something is wrong.
- If you drop or damage a seal, do not install it before an inspection has been carried out.
- Do not run any seal options dry.

WARNING

i) Terminology.

a) "Quench"

- To provide a liquid barrier, which is not, induced to flow through the seal area by any external means.

b) "Flush"

- To provide a liquid barrier that is induced to flow through the seal area by an external means.

ii) Quench or Flush Media.

WARNING

The media used for quenching or flushing a seal area must be fully compatible with the pumped media, and the relevant materials of construction of the pump.



Special consideration must be given to the temperature limitations of the media to ensure that no hazards are created, e.g. risk of fire or explosion.

This seal arrangement requires a supply of media to the outboard side of the mechanical seal to quench or flush the seal area. The nature of the pumped media and the specific duty conditions will determine whether a 'quench' or 'flush' is required.

A quench provides a static head. The media vessel should be mounted a minimum of 1.5 feet above the pump, preferably directly above the seal area. The interconnecting pipework should be as straight as possible, avoiding horizontal runs, and with the minimum number of bends and restrictions.

For a suitable flush, the media must be supplied at a flowrate of three litres per minute per shaft seal (0.8 US Gal per min).

WARNING

Note: The limiting 'flush' or 'quench' pressure in any application is 0.5 bar (7 psi).

4.3.2 RTP20 O-Ring Seal Removal and installation.

Fig 20 O-Ring Seal.

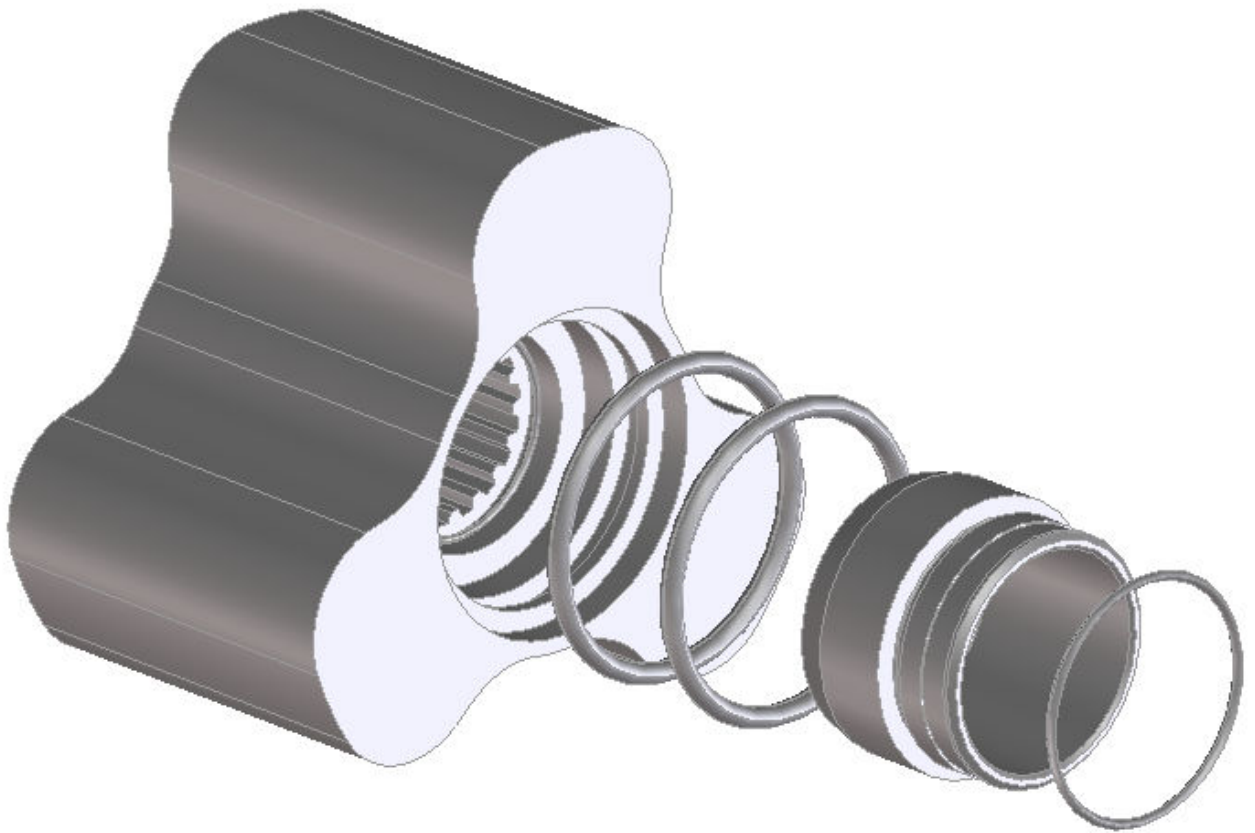

WARNING

Note: Extreme care should be taken when carrying out these procedures to ensure that the O-ring grooves, sleeve faces and O-ring are not damaged.

- Remove the front cover dome nuts, front cover, rotor retainer and rotor as per section 4.1.1
- The seal O-rings in the rotor are now ready for inspection and replacement if needed (Fig 20).

- To remove the rotorcase sleeve remove the screws and pull the sleeve out from the rotorcase (Fig 21).
- The sleeve and sleeve o-ring can now be inspected and replaced if needed.
- To install the sleeve make sure the sleeve o-ring is in place and the location slot lines up with the drive pins , When it is in place tighten up the grub screws and the assembly will be held in place.

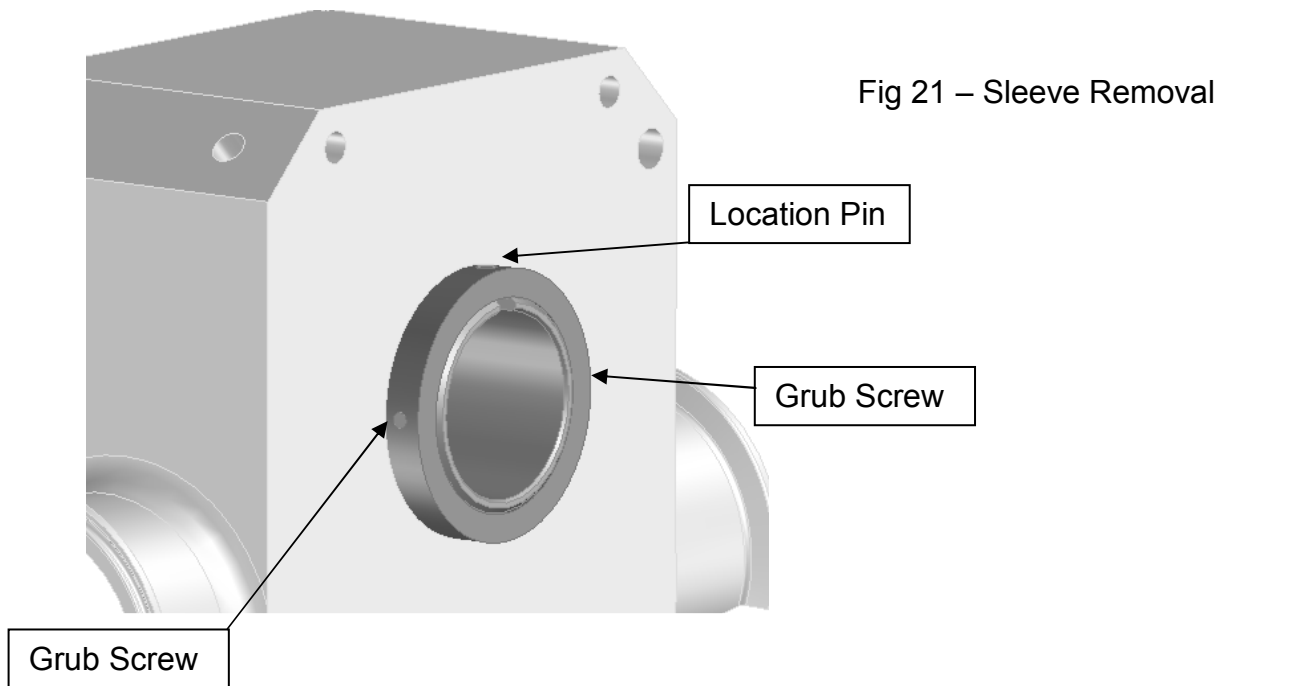

Fig 21 – Sleeve Removal

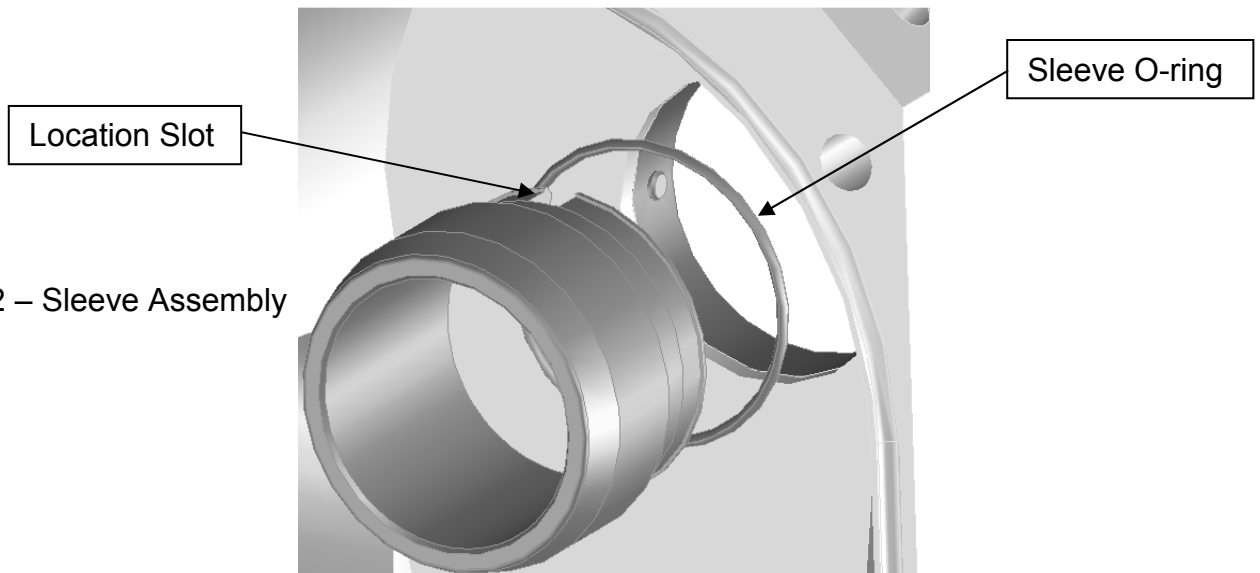

Fig 22 – Sleeve Assembly

- To install the rotors see section 4.2.6 Rotor clearance check – installation

WARNING

NOTE :- The grub screws are only required on the RTP20 O-ring seal

4.3.3 RTP20 Mechanical Seal.

- Remove the front cover dome nuts, front cover, rotor retainer and rotor as per section 4.1.1
- Remove the rotary seal face using the seal extractor tool and inspect or replace the o-rings as required. When installing the seal face ensure correct engagement of the two drive dogs (Fig 23).

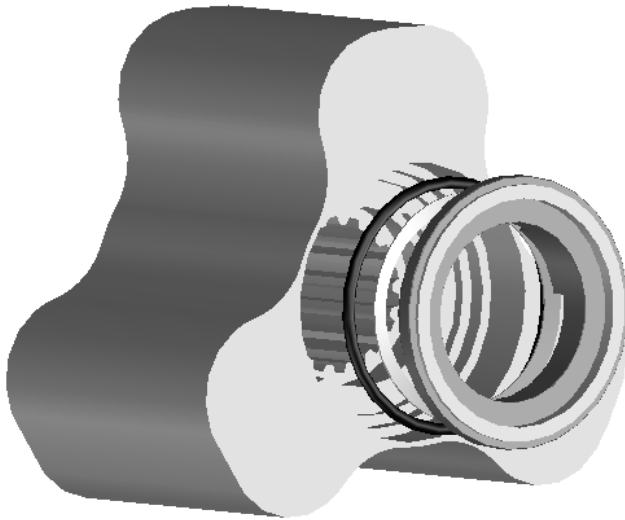
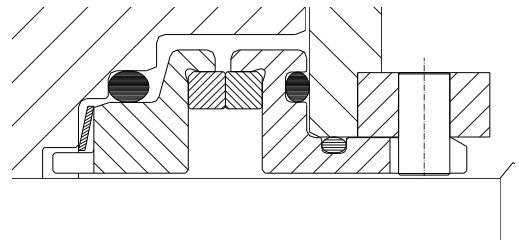

Fig 23 Mechanical Seal



- Remove the static seal face using the seal extractor tool and inspect or replace the O-rings as required.

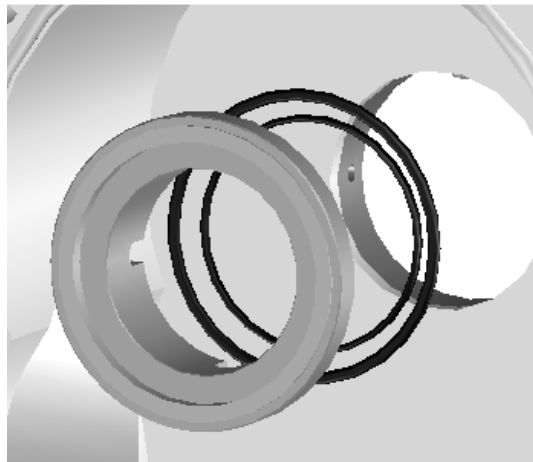

Fig 24 – Mechanical Seal Assembly

- When installing the static face into the rotorcase make sure that the slot in the static face lines up with the pin in the rotorcase (Fig 24).
- To install the rotors see section 4.2.6 Rotor clearance check – installation

WARNING

NOTE:- If replacing an o-ring seal for a mechanical seal remove the grub screw shown in section 4.3.2 and dispose of them as they can interfere with the operation of the mechanical seal

4.3.4 RTP30 Class 1 Hygienic Mechanical Seal.

Fig 25 Class 1 Hygienic Mechanical Seal.

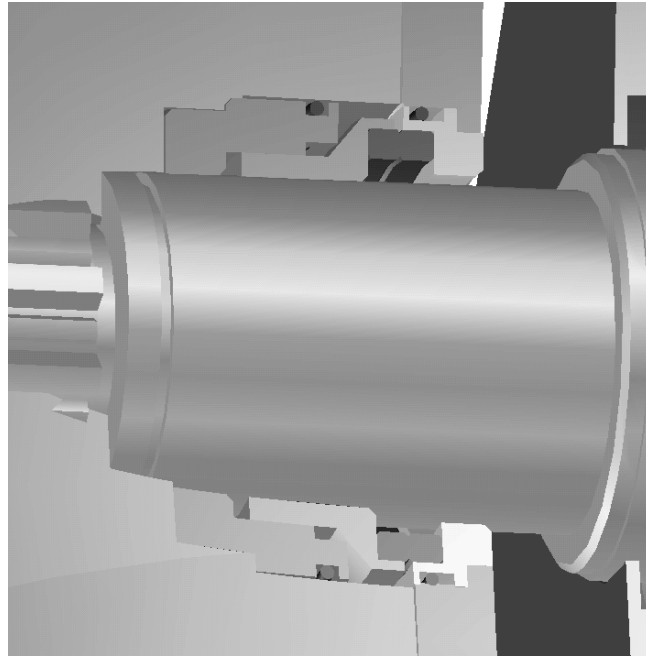

- Read the general procedures before proceeding, refer to section 4.3.1.
- Remove dome nuts (36), front cover (38), rotor retainers (35), rotors (41) and front cover o-ring (39), see section 4.1.
- The seal can now be accessed for inspection.
- Remove the rotary seal face assembly from inside the rotor, taking care not to damage the o-rings.
- Remove the stationary seal assembly from the rotorcase by releasing the retaining nut (12). Note that there is an anti-rotation device incorporated into the rotorcase (not shown), when replacing the seal, alignment between the seal and rotorcase must be achieved to prevent rotation.

WARNING

WARNING

Note: Extreme care should be taken when carrying out these procedures to ensure that the seal faces are not damaged. If seals are being refitted, ensure that seal faces remain matched.

- Assembly is the reverse of the above procedure, ensure that all faces are clean and free from damage.

4.3.5 RTP30 Class 2 Hygienic Mechanical Seal.

Fig 26 Class 2 Hygienic Mechanical Seal.

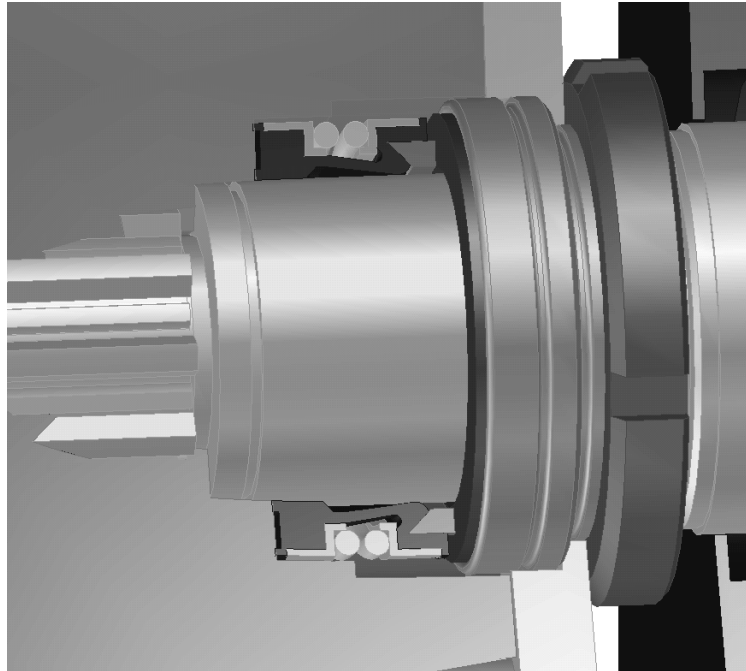

Read the general procedures before proceeding, refer to section 4.3.1.

- Remove dome nuts (36), front cover (38), rotor retainers (35), rotors (41) and front cover o-ring (39), see section 4.1.
- The seal can now be accessed for inspection.
- Remove o-ring (25), from the end of the shaft.
- Remove the rotary seal face assembly from the shaft.
- If required, remove the seal housing (67) from the rotorcase by releasing the retaining nut (12), care should be taken as the stationary seal face may still be installed.

WARNING

- If required, extract the stationary face from the seal sleeve, exposing the o-rings. Note that there is an anti-rotation device incorporated into the rotorcase (not shown), when replacing the seal housing (67), alignment between the seal sleeve and rotorcase must be achieved to prevent rotation.

WARNING

Note: Extreme care should be taken when carrying out these procedures to ensure that the seal faces are not damaged. If seals are being refitted, ensure that seal faces remain matched.

WARNING

- Assembly is the reverse of the above procedure, ensure that all faces are clean and free from damage.

4.3.6 RTP30 Standard Radial Lip Seal.

Fig 27 Standard Radial Lip Seal Cartridge.

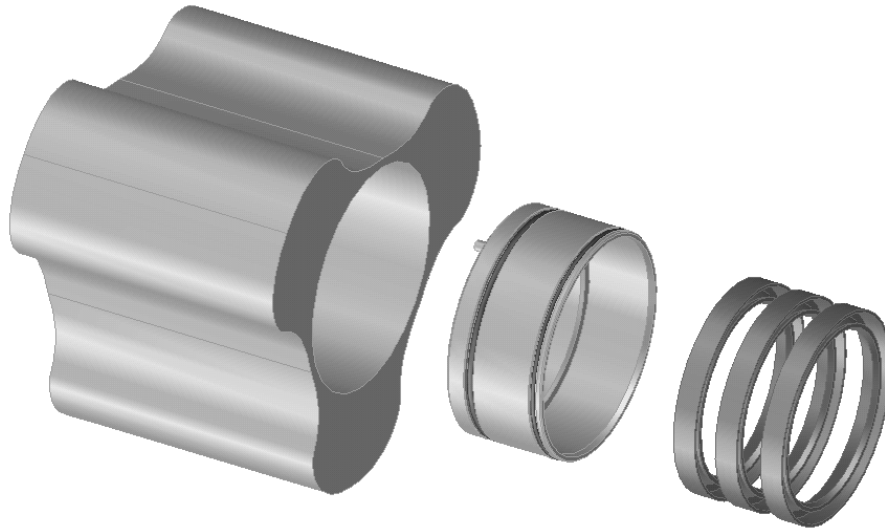

Read the general procedures before proceeding, refer to section 4.3.1.

- Remove dome nuts (36), front cover (38), rotor retainers (35), rotors (41) and front cover o-ring (39), see section 4.1.
- Remove the lip seal cartridge assembly from the rotor (41).
- The seals can now be accessed for inspection.
- The individual lip seals can now be removed and replaced (if required) from the cartridge.
- If required, remove the seal sleeve (66) from the rotorcase by releasing the retaining nut (12), when replacing the seal sleeve (66), alignment between the seal sleeve and rotorcase must be achieved to prevent rotation.

WARNING

WARNING **Note: Extreme care should be taken when carrying out these procedures to ensure that the seal faces are not damaged.**

- Assembly is the reverse of the above procedure, ensure that all faces are clean and free from damage.
- To install the lip seals, press each seal into position and apply suitable lubricant to the second & third seals.

4.3.7 RTP30 O-Ring Seal.

Fig 28 O-Ring Seal Cartridge.

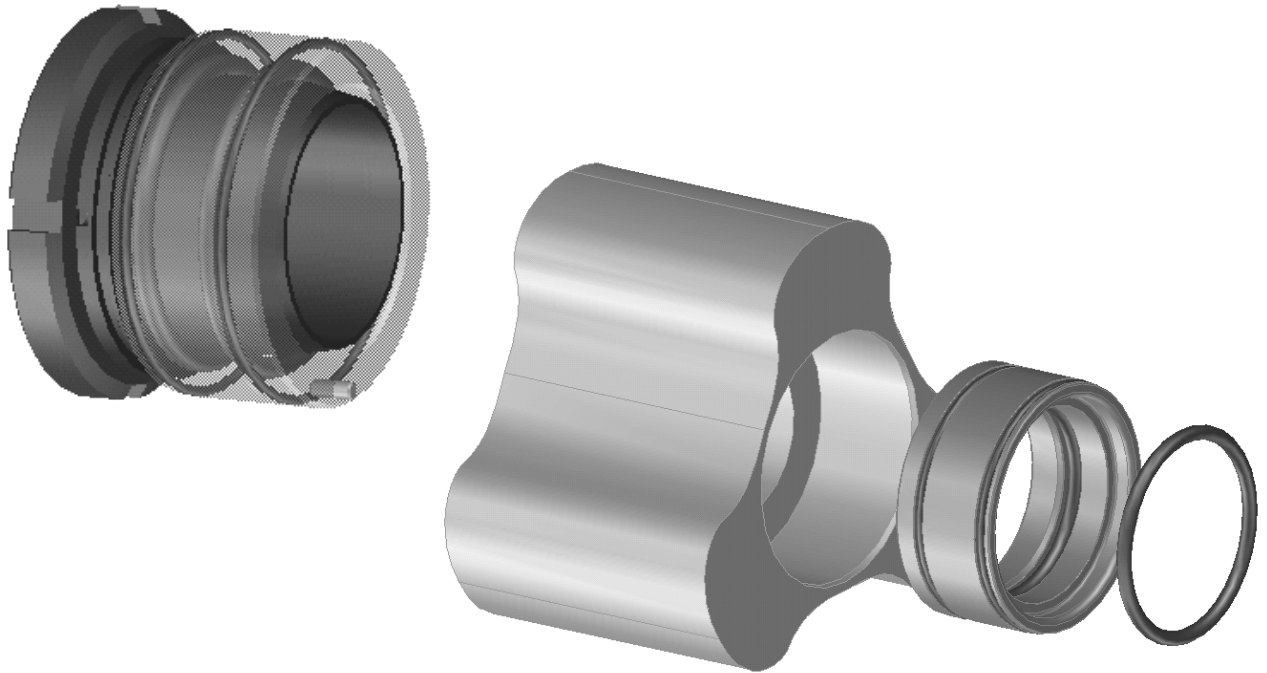

Read the general procedures before proceeding, refer to section 4.3.1.

- Remove dome nuts (36), front cover (38), rotor retainers (35), rotors (41) and front cover o-ring (39), see section 4.1.
- Remove the o-ring seal cartridge assembly from the rotor (41).
- The seals can now be accessed for inspection.
- The o-ring seals can now be removed and replaced (if required) from the cartridge.
- If required, remove the seal sleeve (66) from the rotorcase by releasing the retaining nut (12), when replacing the seal sleeve (66), alignment between the seal sleeve and rotorcase must be achieved to prevent rotation.

WARNING

WARNING

Note: Extreme care should be taken when carrying out these procedures to ensure that the seal faces are not damaged.

- Assembly is the reverse of the above procedure, ensure that all faces are clean and free from damage. Apply suitable lubricant to the second seals.

5.0 Specifications.

5.1 Clearance Chart

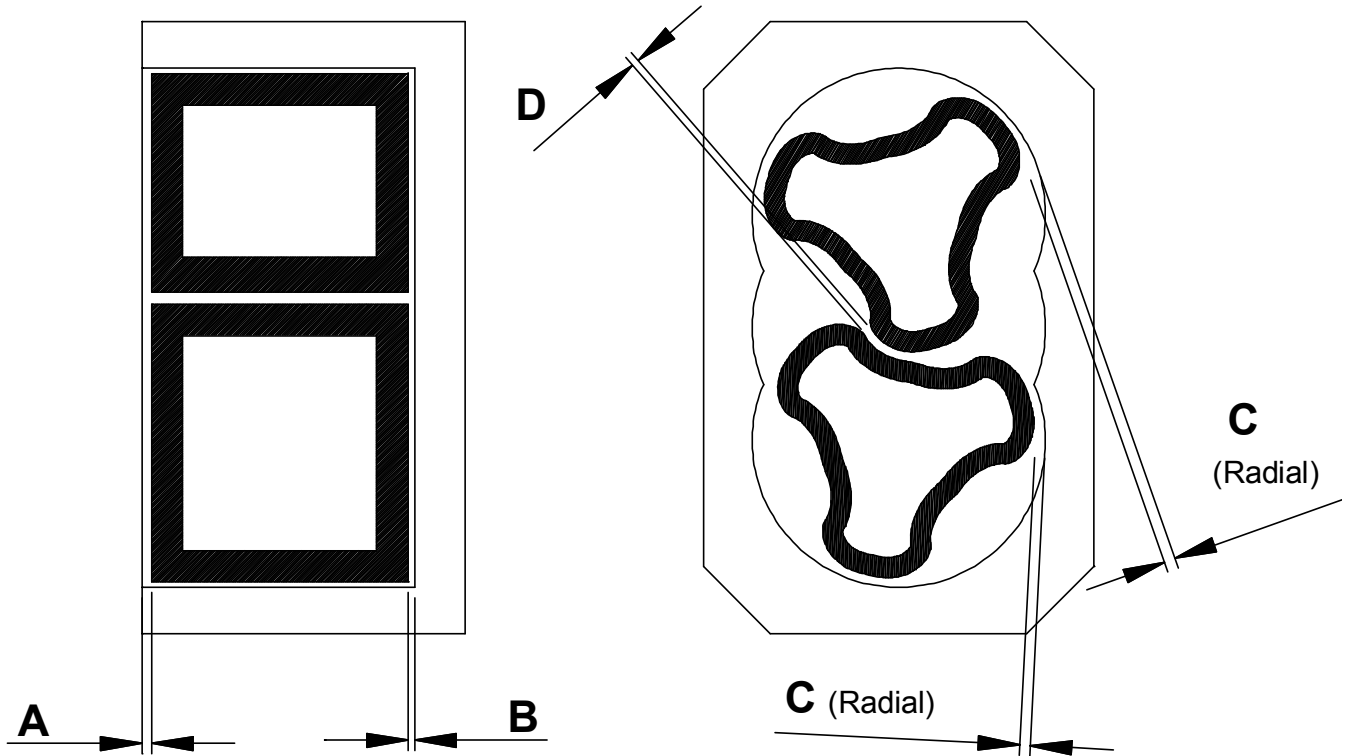

		A		B		C		D	
RTP20	Millimetres	0.3	0.6	0.25	0.55	0.45	0.65	0.25	0.4
	Inches	0.012	0.024	0.010	0.022	0.018	0.026	0.010	0.016
RTP30	Millimetres	0.3	0.7	0.25	0.6	0.55	0.75	0.35	0.5
	Inches	0.012	0.028	0.010	0.024	0.022	0.030	0.014	0.020

5.2 Fasteners & Torque Settings.

Item	Description	Position		RTP20	RTP30
2	Socket Head Cap Screw	Foot / Rotorcase	Quantity / Pump Size Torque (NM)	4 M10 x 16 45	4 M10 x 20 45
7	Socket Head Cap Screw	Gearbox / Rotorcase	Quantity / Pump Size Torque (NM)	4 M10 x 55 45	8 M10 x 45 45
-	Seal Lock Nut (See 1.0)	Rotorcase	Quantity / Pump Size Torque (NM)	N/A	2 M65 x 2.0 50
14	Socket Head Cap Screw	Timing Gear / Shaft	Quantity / Pump Size Torque (NM)	10 M6 x 20 16	5 M6 x 20 16
35	Retainer	Rotor / Shaft	Quantity / Pump Part No. Torque (NM)	2 G33-2052-01 108	2 C33-2051-01 108
36	Dome Nut (Acorn)	Front Cover / Rotorcase	Quantity / Pump Size Torque (NM)	4 M12 55	8 M10 58
37	Stud	Front Cover / Rotorcase	Quantity / Pump Size Torque (NM)	4 M12 x 38 107	8 M10 x 30 45
56	Hammer Drive Screw	Nameplate / Gearbox	Quantity / Pump Size Torque (NM)	4 - -	4 - -
74	Socket Head Cap Screw	Endplate / Gearbox	Quantity / Pump Size Torque (NM)	10 M8 x 30 17	6 M10 x 25 45
-	Individual Shaft Rolling (Product and Lip Seal Not		Rolling Torque (NM)	2.0 to 2.5	2.0 to 2.5

- Notes: 1. See product seal section 4.3 where applicable.
 2. For position of items see section 5.6, typical basic pump build.

5.3 Lubricants.

Grease

The recommended synthetic gearbox grease for use in the RTP™ is one that is intended for ‘sealed’ units. Suitable for operating temperatures between 20°C and 120°C (-4°F to 248°F) and a base viscosity in the region of 150 Cst at 40°C (104°F).

Oil

The recommended gearbox oil for use in the RTP™ is an “EP (Extreme Pressure) grade gear lube”. The following grades should be used in these temperature ranges:

EP150	-18 to 0°C	(0 to 32°F)
EP220	0 to 30°C	(32 to 85°F)
EP320	30°C and higher.	(85°F and higher)

Care should be taken not to overfill the gearbox.

Refer to manufacturers recommended operating conditions concerning limitations, servicing and application. In case of doubt, please consult the factory with details.

Approximate gearbox capacity when pump inlet/outlet ports are orientated in:

	<u>Horizontal Plane</u>		<u>Vertical Plane</u>	
	<u>litres</u>	<u>US Gallons</u>	<u>litres</u>	<u>US Gallons</u>
RTP 20	1.1	0.29	1.1	0.29
RTP 30	0.575	0.15	0.575	0.15

5.4 Tool List.

Listed below are tools required for the maintenance of the RTP™ pump.

RTP20

TYPE	SIZE OR RANGE
HEXAGON (ALLEN) KEY	3 MM
HEXAGON (ALLEN) KEY	5 MM
HEXAGON (ALLEN) KEY	8 MM
COMBINATION SPANNER	19 MM
TORQUE WRENCH	ADJUSTABLE TO MIN. 135 NM (99.57 FT-LB)
DEPTH MICROMETER	0 - 25 MM (0 - 1")
FEELER GAUGE SET	0.03 MM TO 0.50 MM (0.0012" TO 0.0197") – 388M
ROLLING TORQUE METER	0 - 5 NM (0 - 3.69 FT-LB)
SOFT-FACED MALLET	
STEEL HAMMER	SMALL

RTP30

TYPE	SIZE OR RANGE
HEXAGON (ALLEN) KEY	5 MM
HEXAGON (ALLEN) KEY	8 MM
COMBINATION SPANNER	17 MM
TORQUE WRENCH	ADJUSTABLE TO MIN. 135 NM (99.57 FT-LB)
DEPTH MICROMETER	0 - 25 MM (0 - 1")
FEELER GAUGE SET	0.03 MM TO 0.50 MM (0.0012" TO 0.0197") – 388M
ROLLING TORQUE METER	0 - 5 NM (0 - 3.69 FT-LB)
SOCKET FOR ROTOR RETAINER	SUPPLIED WITH PUMP
HOOK WRENCH (HN12)	TO SUIT LOCKNUT OUTSIDE Ø 85MM (3.346")
SOFT-FACED MALLET	
STEEL HAMMER	SMALL

5.5 RTP30 Foundation Dimensions – Stub Shaft Drive.

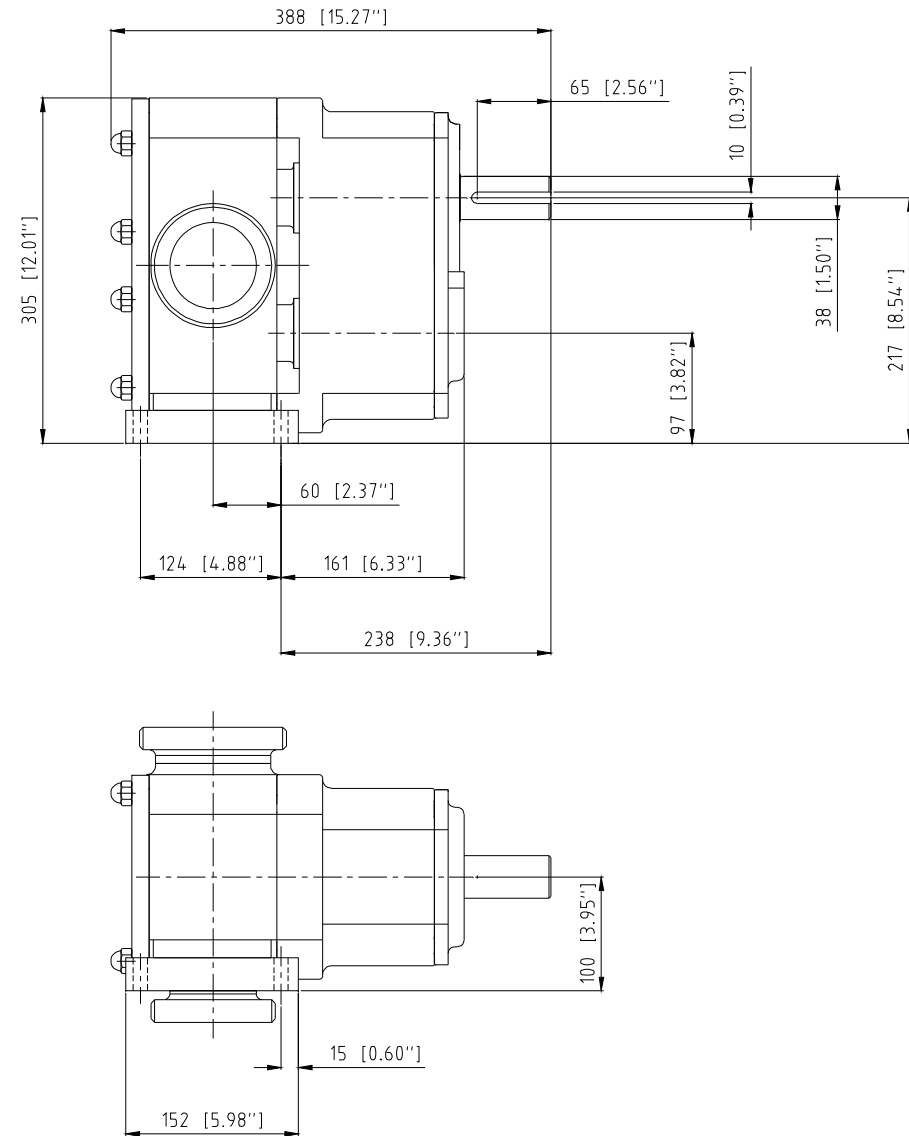
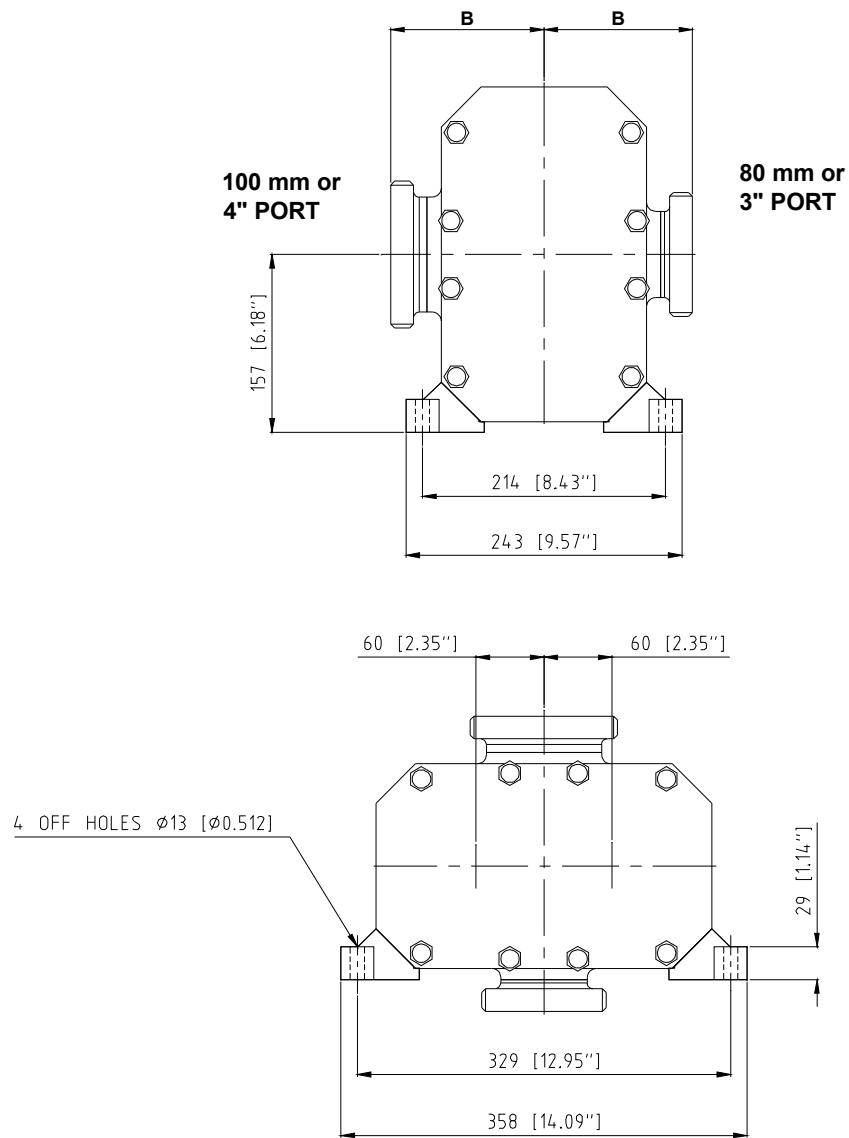

5.5.1 RTP20 and 30 Foundation Dimensions – Basic Pump (Hydraulic Drive)

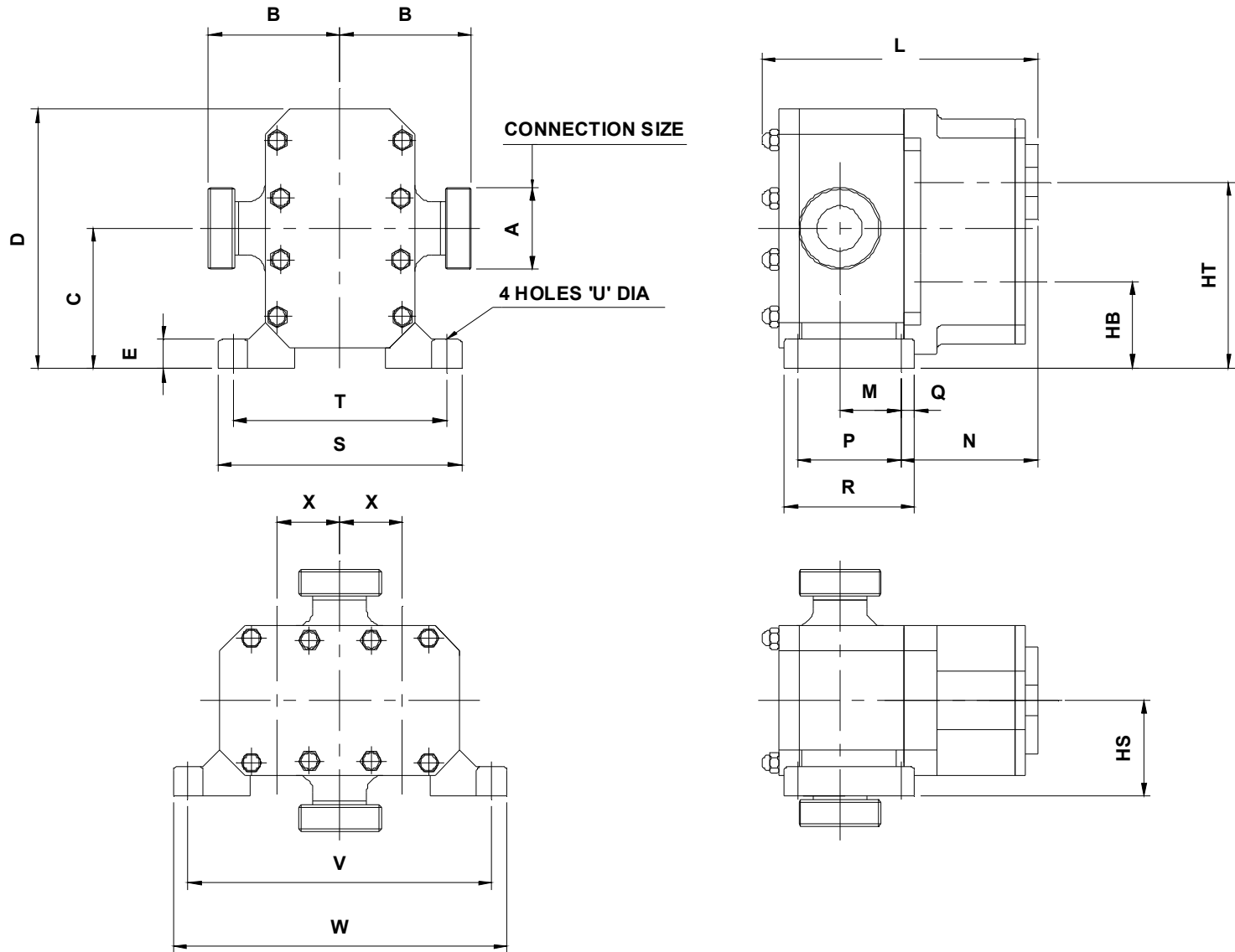

Dimensions in millimetres

	A	B1	B2	B3	B4	B5	C	D	E	HB	HS	HT	L	M	N	P	Q	R	S	T	U	V	W	X	Weight (kg)
RTP20	50	117	139	131	131	139	142	275	22	88	88	196	299	42	174	90	14	117	222	195	11	303	330	54	49
	80		149		139	144																			
RTP30	80	131	163	145	153	158	157	305	29	97	100	217	311	62	161	124	14	152	243	214	13	329	358	60	67
	100	135	178																						

Dimensions in Inches

	A	B1	B2	B3	B4	B5	C	D	E	HB	HS	HT	L	M	N	P	Q	R	S	T	U	V	W	X	Weight (lb)
RTP20	2"	4.61	5.47	5.16	5.16	5.47	5.59	10.83	0.87	3.46	3.46	7.72	11.77	1.65	6.85	3.54	0.55	4.61	8.74	7.68	0.43	11.93	12.99	2.13	108
	3"		5.87		5.47	5.67																			
RTP30	3"	5.16	6.42	5.71	6.02	6.22	6.18	12.01	1.14	3.82	3.94	8.54	12.24	2.44	6.34	4.88	0.55	5.98	9.57	8.43	0.51	12.95	14.09	2.36	148
	4"	5.31	7.01																						

B1 applies for all threaded connections (including ACME & Triclamp) except BSPT and NPT.

B2 applies for BSPT and NPT thread connections.

B3 applies for all flange connections except ASA150, BS4504 and ASA300.

B4 applies for ASA150 and BS4504 flange connections.

B5 applies for ASA300 flange connections.

These dimensions are for guidance only – Certified drawings are available on request

5.6 Typical Basic Pump Build

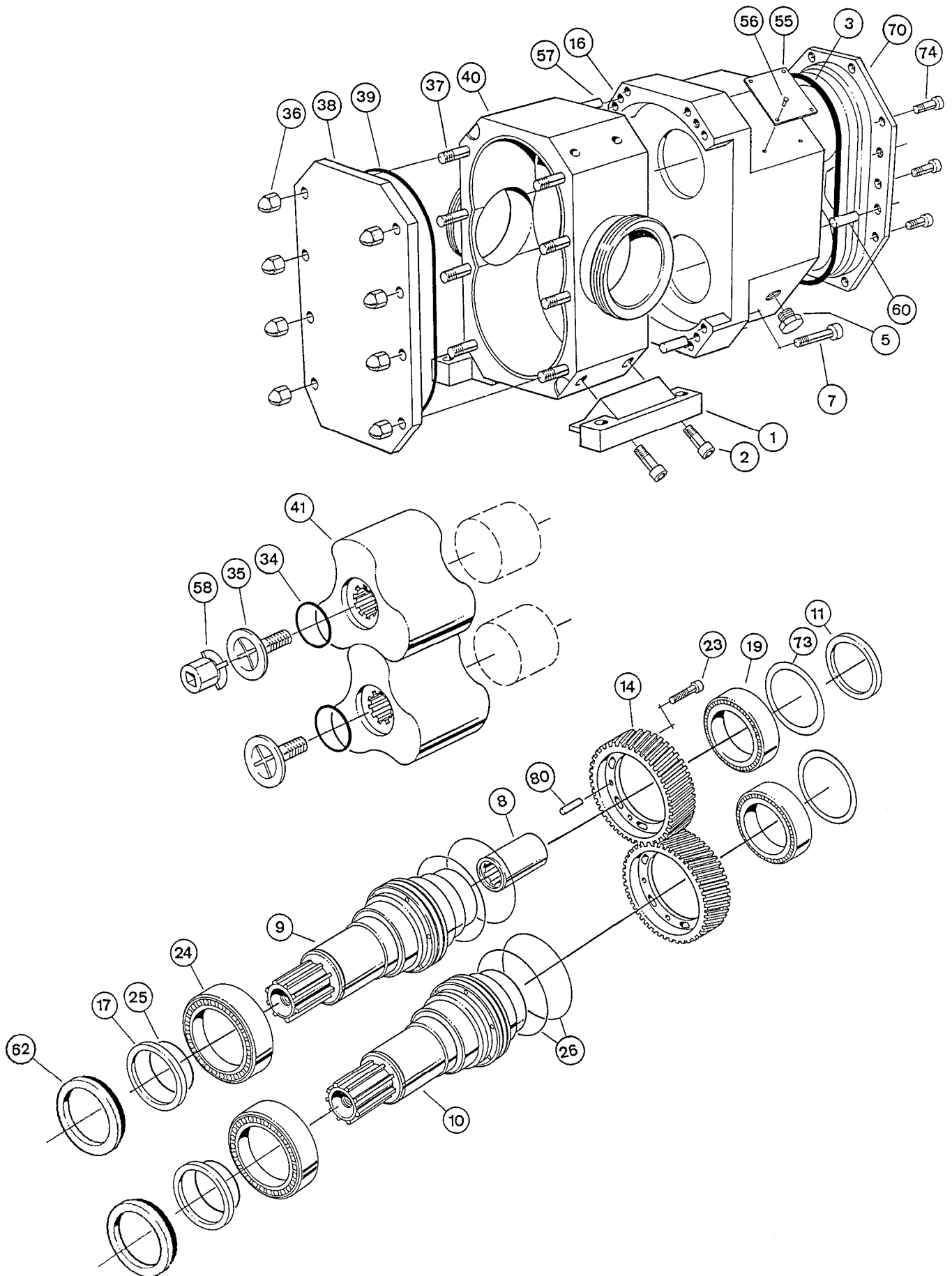

5.7 Trouble Shooting.

No FLOW	IRREGULAR FLOW	UNDER CAPACITY	PUMP OVERHEATS	MOTOR OVERHEATS	EXCESSIVE ROTOR WEAR	EXCESSIVE SEAL WEAR	NOISE / VIBRATION	SEIZURE	PUMP STALLS ON START UP	Causes	ACTION
										INCORRECT DIRECTION OF ROTATION.	REVERSE MOTOR.
										PUMP NOT PRIMED.	EXPEL GAS FROM SUCTION LINE / PUMP CHAMBER & PRIME.
										INSUFFICIENT NPSH AVAILABLE.	INCREASE SUCTION LINE & STATIC SUCTION HEAD DIAMETER. SIMPLIFY SUCTION LINE & REDUCE LENGTH. REDUCE PUMP SPEED & PRODUCT TEMPERATURE.
										PRODUCT VAPORISING IN SUCTION LINE.	
										AIR ENTERING SUCTION LINE.	REMAKE PIPEWORK JOINTS.
										GAS IN SUCTION LINE.	EXPEL GAS FROM SUCTION LINE / PUMP CHAMBER.
										INSUFFICIENT STATIC SUCTION HEAD.	RAISE PRODUCT LEVEL TO INCREASE STATIC SUCTION HEAD.
										PRODUCT VISCOSITY TOO HIGH.	DECREASE PUMP SPEED / INCREASE PRODUCT TEMPERATURE.
										PRODUCT VISCOSITY TOO LOW.	INCREASE PUMP SPEED / INCREASE PRODUCT TEMPERATURE.
										PRODUCT TEMPERATURE TOO HIGH.	COOL PRODUCT / PUMPING CHAMBER.
										PRODUCT TEMPERATURE TOO LOW.	HEAT PRODUCT / PUMPING CHAMBER.
										UNEXPECTED SOLIDS IN PRODUCT	CLEAN SYSTEM / FIT STRAINER ON SUCTION SIDE OF PUMP.
										DISCHARGE PRESSURE TOO HIGH	CHECK FOR BLOCKAGES / SIMPLIFY DISCHARGE LINE.
										ROTORCASE STRAINED BY PIPEWORK.	CHECK PIPE ALIGNMENT / SUPPORT PIPEWORK.
										PUMP SPEED TOO HIGH	DECREASE PUMP SPEED.
										PUMP SPEED TOO LOW	INCREASE PUMP SPEED
										SEAL FLUSH INADEQUATE	INCREASE SEAL FLUSH TO REQUIRED PRESSURE / FLOW.
										BEARING / TIMING GEAR WEAR	REPLACE WORN COMPONENTS.

5.8 RTP™ Service History.

Pump Serial No:

Date	Comments

5.9 Notes.

The information contained in this document is correct at time of print, but may be subject to change without prior notice.



Wright Flow Technologies Ltd.
Edison Road, Eastbourne,
East Sussex, BN23 6PT
United Kingdom

Phone: +44 1323 509211
Fax: +44 1323 507306
E-mail: wright.eu@idexcorp.com

Wright Flow Technologies, Inc.
406 State Street
Cedar Falls, Iowa 50613 U.S.A.

Phone: (319) 268-8013
Fax: (803) 216-7686
E-mail: wright.usa@idexcorp.com

www.wrightflowtechnologies.com

Issue T – 17/02/2016