



Installation, Operation
And
Maintenance Manual
For The



Frame 2,3,4 and 5

Range of Pumps



Installation, Operation & Maintenance Manual For The Revolution Range of Pumps

<u>1.0</u>	<u>Safety Information.</u>	<u>4</u>
1.1	Risk assessment relating to the use of Wright Flow Technologies Revolution pumps and pump units in potentially explosive atmospheres.	7
<u>2.0</u>	<u>Introduction.</u>	<u>8</u>
2.1	General.	8
2.2	Wright Flow Technologies Distributors.	8
2.3	Receipts and Storage.	8
2.4	Cleaning.	8
2.5	Pump Model Designation.	8
2.5.1	Pump Model and Serial Number.	9
2.5.2	ATEX Information	10
2.5.3	Equipment Groups & Categories.	10
<u>3.0</u>	<u>General.</u>	<u>12</u>
3.1	Revolution Pumping Principal.	12
3.2	Revolution Pump Head Modularity.	12
3.3	Revolution Range Operating Parameters.	13
3.4	System Design.	15
3.4.1	System Design and Installation.	15
3.4.2	Installations with CIP Systems.	18
3.5	Start Up Procedure.	18
3.6	Shutdown Procedure.	19
3.7	Routine Maintenance.	20
3.8	Flushing Positions Size 2,3,4	21
3.8.1	Flushing Positions Size 5	22
3.8.2	Recommended Flush Circulation.	23
3.8	Heating / Cooling.	25
3.8.1	Rotorcase Heating Jacket installation	27
3.8.2	Front Cover Heating Jacket installation	29

<u>4.0</u>	<u>Revolution Disassembly and Assembly.</u>	<u>31</u>
4.1	Disassembly.	33
4.1.1	Front Cover and Rotor Removal.	33
4.1.2	Rotorcase Removal.	34
4.1.3	Gearbox Disassembly.	35
4.1.5	Front Spacers and Lip-seals.	37
4.1.6	Shaft and Bearing Removal.	38
4.2	Assembly.	39
4.2.1	Shaft Assembly.	39
4.2.2	Gearbox.	40
4.2.3	Shaft Installation.	41
4.2.4	Timing Marks and Drive Gear Identification.	42
4.2.5	Timing.	43
4.2.7	Gearbox / Rotorcase Assembly.	45
4.2.8	Front Clearance.	47
4.2.9	Final Assembly Size 2,3 and 4.	48
4.2.10	Final assembly Size 5.	49
<u>5.0</u>	<u>Seal Section.</u>	<u>50</u>
5.1	Single Seal.	50
5.2	Double Seal – Flushed.	52
5.3	Single O-Ring Seal.	54
5.4	Double O-Ring Seal – Flushed.	56
5.5	Flushed Product Seals Auxiliary Services.	58
5.6	Double Mechanical Seal.	58
5.7	Operating parameters	59
<u>6.0</u>	<u>Specifications.</u>	<u>60</u>
6.1	Clearance Chart.	60
6.2	Fasteners & Torque Settings.	64
6.3	Lubricants.	64
6.3	Material Specifications and Pump Weights.	67
6.5	Pump Lifting.	67
6.6	Foundation Dimensions.	68
6.7	Trouble Shooting.	71
6.8	Typical Noise Emission Data.	72
6.9	Tool List.	72
<u>7.0</u>	<u>Service History.</u>	<u>74</u>
<u>7.1</u>	<u>Notes</u>	<u>75</u>

1.0 Safety Information.

INCORRECT INSTALLATION, OPERATION, OR MAINTENANCE OF EQUIPMENT MAY CAUSE SEVERE PERSONAL INJURY OR DEATH AND/OR EQUIPMENT DAMAGE AND MAY INVALIDATE THE WARRANTY.

THIS INFORMATION MUST BE READ FULLY BEFORE BEGINNING INSTALLATION, OPERATION, OR MAINTENANCE AND MUST BE KEPT WITH THE PUMP. SUITABLY TRAINED OR QUALIFIED PERSONS MUST UNDERTAKE ALL INSTALLATION AND MAINTENANCE ONLY.

Danger - Failure to follow the listed precautionary measures may result in serious injury or death are identified by the following symbol:



Warning - Safety instructions which shall be considered for reasons of safe operation of the pump or pump unit and/or protection of the pump or pump unit itself are marked by the sign:

WARNING

DANGER

DO NOT OPERATE PUMP IF:



- The front cover is not installed correctly.
- Any guards are missing or incorrectly installed.
- The suction or discharge piping is not connected.



DO NOT place fingers, etc. into the pumping chamber or its connection ports or into any part of the gearbox if there is ANY possibility of the pump shafts being rotated. Severe injury will occur.



DO NOT exceed the pumps rated pressure, speed, and temperature, or change the system/duty parameters from those for which the pump was originally supplied, without confirming its suitability for the new duty. Running of the pump outside of its operation envelope can cause mechanical contact, excessive heat and can represent a serious risk to health and safety.



Installation and operation of the pump must always comply with health and safety regulations.

WARNING

A device must be incorporated into the pump, system, or drive to prevent the pump exceeding its stated duty pressure. It must be suitable for both directions of pump rotation where applicable. Do not allow pump to operate with a closed/blocked discharge unless a pressure relief device is incorporated. If an integral relief valve is incorporated into the pump, do not allow re-circulation through the relief valve for extended periods.



The mounting of the pump or pump unit should be solid and stable. Pump orientation must be considered in relation to drainage/cavity ventilation requirements. Once mounted, shaft drive elements must be checked for correct alignment. Rotate pump shaft by at least one full revolution to ensure smoothness of operation. Incorrect alignment will produce excessive loading and will create high temperatures and increased noise emissions. It may also be necessary to earth the pump head to avoid the build up of a potential charge difference that could cause a spark.



The installation must allow safe routine maintenance and inspection (to replenish lubricants, check for leakage, monitor pressures, etc) and provide adequate ventilation necessary to prevent overheating.

WARNING

Fill all gearboxes with the recommended grades and quantities of lubricant (refer to section 3.5 and 6.3). Beware of over/under filling the gearbox as this could cause the pump to overheat and mechanical damage to occur.

WARNING

Before operating the pump, be sure that it and all parts of the system to which it is connected are clean and free from debris and that all valves in the suction and discharge pipelines are fully opened. Ensure that all piping connecting to the pump is fully supported and correctly aligned with its relevant connections. Misalignment and/or excess loads will cause severe pump damage. This could result in unexpected mechanical contact in the pump head and has the potential to be an ignition source.

WARNING

Be sure that pump rotation is correct for the desired direction of flow (refer to section 3.5).

WARNING

Do not install the pump into a system where it will run dry (i.e. without a supply of pumped media) unless it is equipped with a flushed shaft seal arrangement complete with a fully operational flushing system. Mechanical seals require a thin fluid film to lubricate the seal faces. Dry running can cause excessive heat and seal failure.

WARNING

Pressure gauges/sensors are recommended, next to the pump suction and discharge connections to monitor pressures.



Caution must be taken when lifting the pump. Suitable lifting devices should be used as appropriate. Lifting eyes installed on the pump must only be used to lift the pump, not pump with drive and/or base plate. If pump is base plate mounted, the base plate must be used for all lifting purposes. If slings are used for lifting, they must be safely and securely attached. For weights of bare shaft pumps refer to section 6.4.



DO NOT attempt any maintenance or disassembly of the pump or pump unit without first ensuring that:

- The pump is fully isolated from the power source (electric, hydraulic, pneumatic).
- The pumping chamber and any shaft seal support system are depressurised and purged.
- Any temperature control devices (jackets, heat-tracing, etc) are fully isolated, that they are depressurised and purged, and components are allowed to reach a safe handling temperature.



DO NOT loosen or undo the front cover, any connections to the pump, shaft seal housings, temperature control devices, or other components, until sure that such action will not allow the unsafe escape of any pressurised media.



Pumps and/or drives can produce sound power levels exceeding 85-dB (A) under certain operating conditions. When necessary, personal protection against noise must be taken.



Avoid any contact with hot parts of pumps and/or drives that may cause injury. Certain operating conditions, temperature control devices (jackets, heat-tracing, etc.), bad installation, or poor maintenance can all promote high temperatures on pumps and/or drives.

WARNING

When cleaning, either manually or by CIP method, the operator must ensure that a suitable procedure is used in accordance with the system requirements. During a CIP cleaning cycle, a pump differential pressure of between 2 and 3 bar (30 and 45 psi) is recommended to ensure suitable velocities are reached within the pump head. The exterior of the pump should be cleaned periodically.



Surface temperature of pump is also dependent on the temperature of pumped medium.

1.1 Risk assessment relating to the use of Wright Flow Technologies Revolution pumps and pump units in potentially explosive atmospheres.

Note:- For a feature to be suitable for an application, the feature must be fit for its designated purpose and also suitable for the environment where it is to be installed.

Source Of Hazards	Potential Hazards	Frequency Of Hazards	Recommended Measures
Unvented cavities	Build up of explosive gas	Very Rare	Ensure that pump is totally filled. Consider mounting ports vertically. See Chapter 1.0
Rotorcase / Rotors / Front Cover	Unintended mechanical contact	Rare	Ensure that operating pressures are not exceeded. Ensure that sufficient NPSH to prevent cavitation. See Chapter 1.0/3.4.1 Service plan.
Pump external surfaces	Excess temperature. Electrostatic charging	Rare	User must ensure temperature limits. Do not overfill gearboxes with lubricant. Provide a ground contact for pump. See Chapter 1.0/6.3/ Service plan.
Cover 'O' ring	Pump liquid leakage. Build up of explosive gas.	Very Rare	Check selection of elastomers are suitable for application. Ensure cover retaining nuts are tight. Service plan.
Pump casing/ cover	Pump liquid leakage. Build up of explosive gas.	Very Rare	Stainless steel, Corrosion resistant.
Shaft seals	Excess temperature. Unintended mechanical contact. Leakage. Build up of explosive gas.	Rare	Selection of seal system must be suitable for application. See Chapter 5.0. Service plan. Seals must never run dry.
Auxiliary system for shaft sealing	Pump liquid leakage. Build up of explosive gas.	Rare	Selection of auxiliary seal system must be suitable for application. Seals must never run dry.
Rotation direction test	Excess temperature	Very Rare	If flushed seals are installed ensure that flush is applied to seal assemblies. Only allow pump to run for minimum period - just a few seconds.
Closed valve condition	Excess Temperature. Excess Pressure. Mechanical contact.	Rare	Can cause excessive pressure, heat and mechanical contact. See Chapter 1.0
Shaft	Random induced current	Very Rare	Provide a ground contact for pump. See Chapter 1.0.
Mechanical shaft coupling (Torque Protection)	Temperature from friction Sparks from break up of shear pins. Electrostatic charging	Rare	Coupling selection must suit application. See Chapter 1.0.
Mechanical shaft coupling (standard)	Break up of spider. Unintended mechanical contact. Electrostatic charging	Rare	Coupling selection must suit application. Service plan. See Chapter 1.0.

2.0 Introduction.

2.1 General.

Revolution circumferential piston and rotary lobe pumps are manufactured by Wright Flow Technologies a unit of the IDEX Corporation.

2.2 Wright Flow Technologies Distributors.

Wright Flow Technologies distributes its products internationally via a network of authorised distributors. Throughout this manual where reference is made to Wright Flow Technologies, service and assistance will also be provided by any authorised distributor for Revolution.

2.3 Receipts and Storage.

Upon receipt of the pump, immediately examine it for any signs of visible damage. If any damage is noted, contact Wright Flow Technologies or your Wright Flow Technologies distributor and clearly mark upon the carriers' paperwork that the goods have been received in a damaged condition, with a brief description of damage.

If the pump is not required for immediate installation then it should be stored in a clean, dry environment. It is recommended that storage temperature should be between -10° and 40°C (14°F and 105°F).

2.4 Cleaning.

The Revolution pump series is suitable for both manual cleaning and CIP (Cleaning In Place), refer to section 3.4.2.

It is recommended that the exterior of the pump be cleaned periodically with a non-aggressive, non-abrasive cleaning solution.

2.5 Pump Model Designation.

The designations of pump models in the Revolution range are as follows:

Fig 1 Designations

Size 2		Size 3		Size 4		Size 5
R0150	⇒	R0200	⇒	R0450	⇒	R1800
R0160		R0300		R0600		R2200
R0180	⇒	R0400	⇒	R0800	⇒	R2600
				R1300		

For the maximum operating pressures, temperatures and speeds refer to section 3.3,

Fig 1.

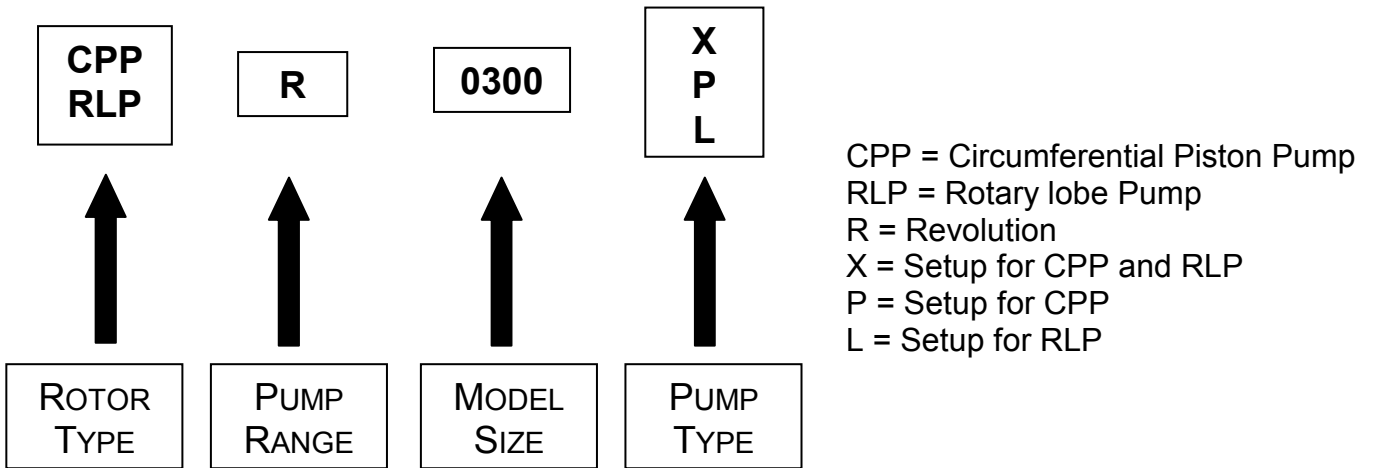

2.5.1 Pump Model and Serial Number.

Should you require any information regarding your Revolution pump contact Wright Flow Technologies or your Wright Flow Technologies distributor, providing the pump model and serial number as stated on the pump nameplate, see Fig 2, which is fixed to the pump gearbox.

Should this be damaged or missing, the pump serial number is also stamped on opposite corners of the rotorcase or on the rear face of the rotorcase, (see Fig 3).

Fig 2 Nameplate

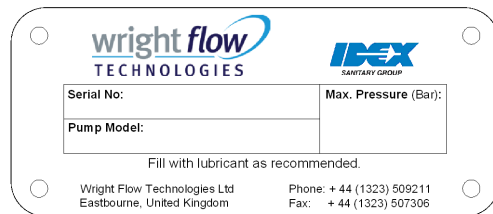
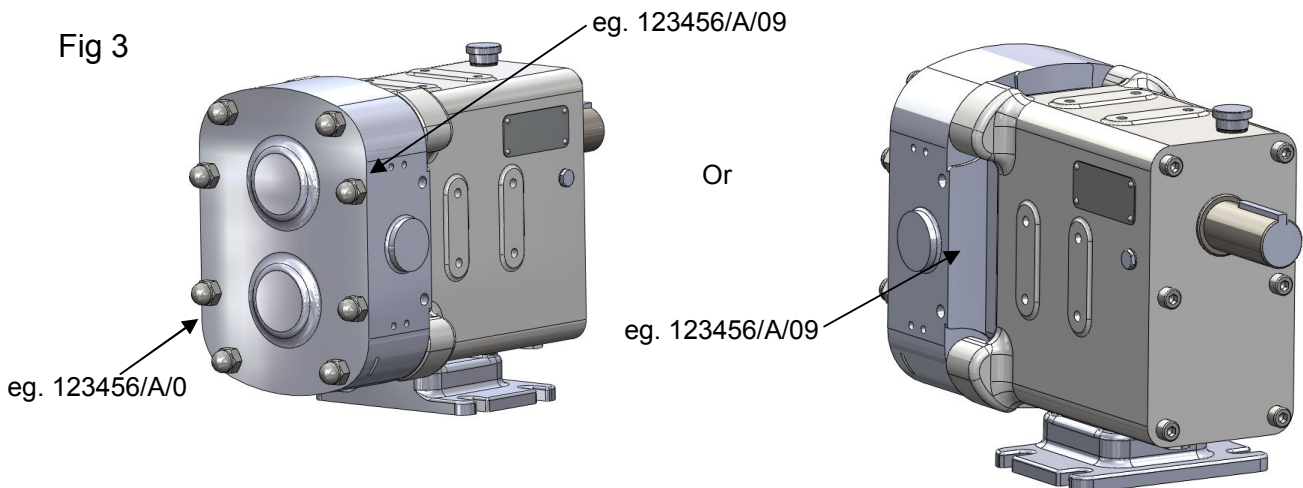

Fig 3



2.5.2 ATEX Information

ATEX Pump Requirements

Please be aware that mechanical seals are a source of heat and must never be allowed to run dry.

We would recommend provision be made to ensure that there is a flow of fluid around the pump seals at all times. If there is a risk of the supply being interrupted, we would recommend that the flush on the seals be fitted with a flow detection device. The surface temperature of the pump is dependent on the temperature of the pumped fluid and due account of this should be taken whilst undertaking your risk assessment of the installation. These pumps are rated to T3.

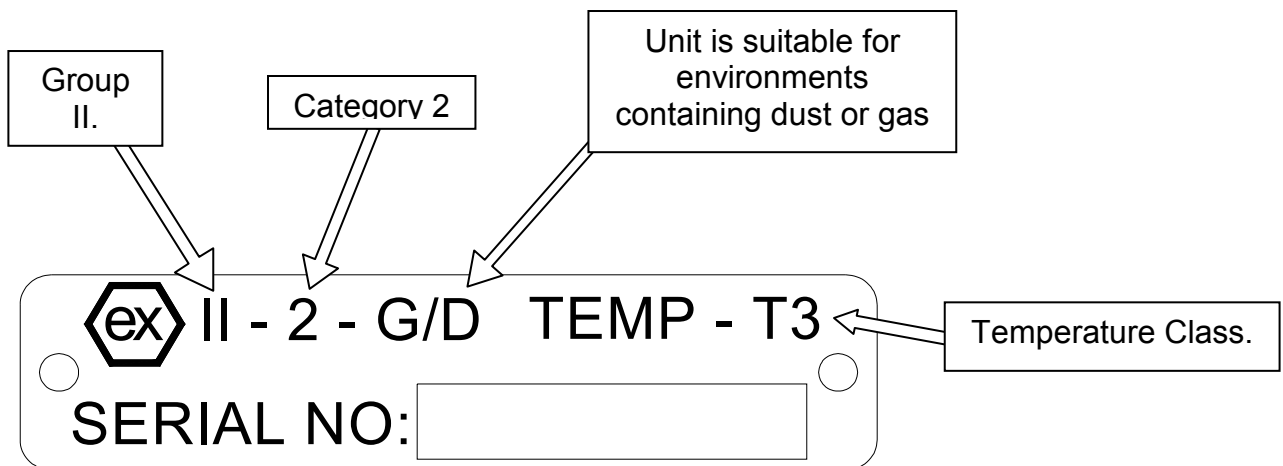

2.5.3 Equipment Groups & Categories.

Equipment-groups (Annex I of the EC-Directive 94/9/EC)							
Group I (mines, mine gas and dust)		Group II (other explosive atmospheres gas/dust)					
Category M		Category 1		Category 2		Category 3	
1	2	G (gas) (Zone 0)	D (dust) (Zone 20)	G (gas) (Zone 1)	D (dust) (Zone 21)	G (gas) (Zone 2)	D (dust) (Zone 22)
for equipment providing a very high level of protection when endangered by an explosive atmosphere	for equipment providing a high level of protection when likely to be endangered by an explosive atmosphere	for equipment providing a very high level of protection when used in areas where an explosive atmosphere is very likely to occur		for equipment providing a high level of protection when used in areas where an explosive atmosphere is likely to occur		for equipment providing a normal level of protection when used in areas where an explosive atmosphere is less likely to occur	

Standard Pump Component Terms (Frame 3 CPP shown)

Fig 4

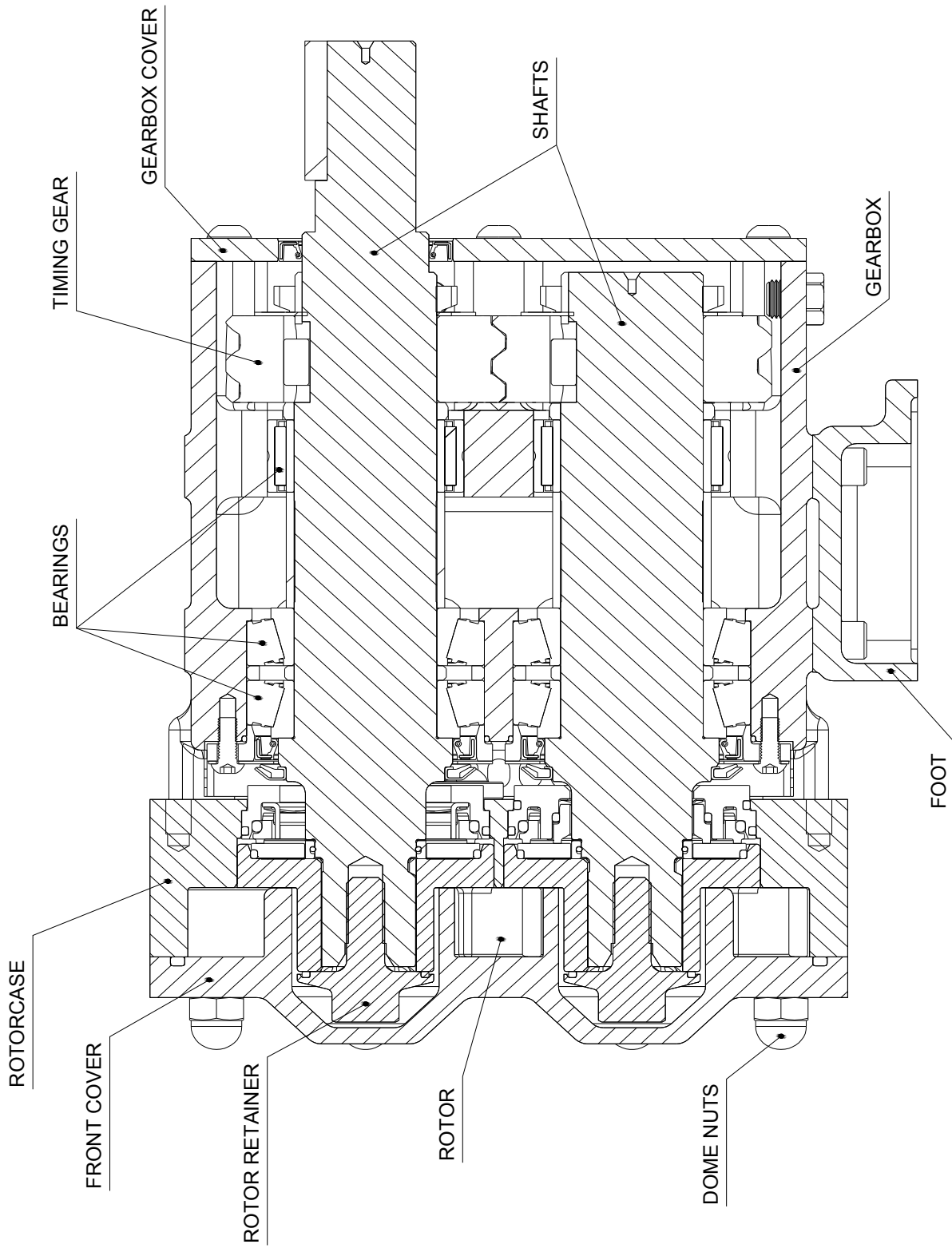

3.0 General.

3.1 Revolution Pumping Principal.

The pumping action is generated by the contra-rotation of two pumping elements (rotors) within a chamber (rotorcase) - see Fig 5. The rotors are located on shafts, which in turn are mounted within an external gearbox and supported by the bearings; the timing gears are also located on the shafts. The timing gears transfer the energy from the drive shaft to the driven shaft, synchronising the rotors such that they rotate without contact with each other.

As the rotors pass the suction port, see Fig 5, the cavity generated increases creating a pressure decrease, which induces the pumped medium to flow into the rotorcase.

The pumped medium is carried around the rotorcase by the rotors to the discharge side of the pump, here the cavity decreases and the pumped medium is discharged from the rotorcase.

For pump component terms see Fig 4.

Fig 5

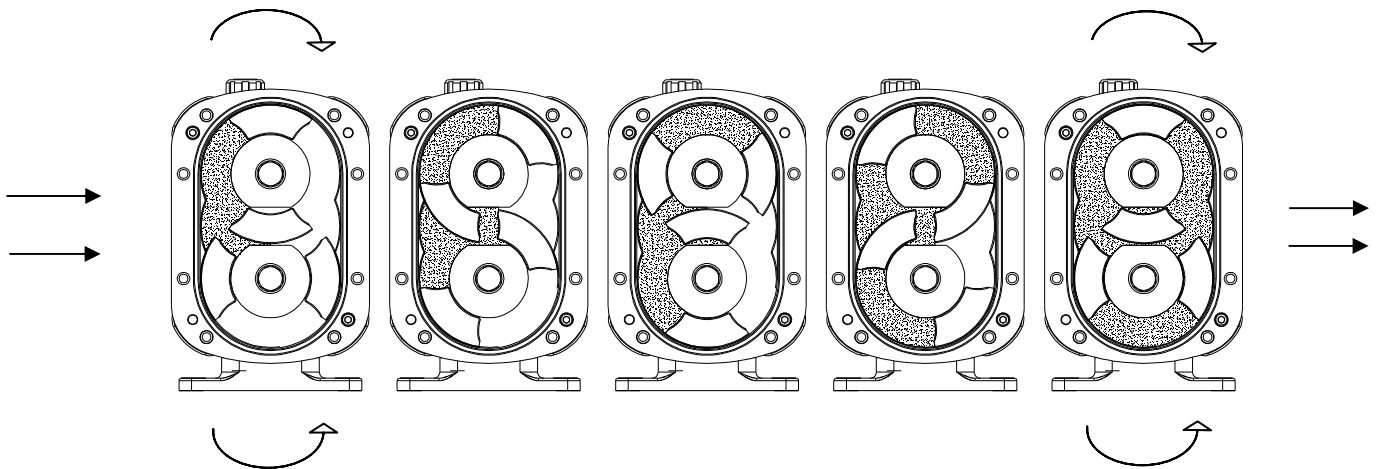

3.2 Revolution Pump Head Modularity.

The Revolution pump has been designed with a universal pump head – This means that on some models by changing the rotors and front cover and a few ancillary items you change between a rotary lobe pump (RLP) and a Circumferential Piston Pump (CPP).



Note when changing between RLP and CPP Timing and clearances must be checked.

3.3 Revolution Range Operating Parameters.

The maximum pressure and speed operating parameters are given in Fig 6. In practice these may be limited due to the nature of the product to be pumped and/or design of the system in which the pump is to be installed. Consult Wright Flow Technologies or your Wright Flow Technologies distributor for assistance.

The operating temperature limit of the pump is determined by the rotor clearance.

For the rotary lobe pumps (RLP):

- Size 1, 2, 3, 4, and 5 series - two rotor clearance bands (70 and 150 degrees C) (158 and 302 degrees F)

For the circumferential piston pumps (CPP) :

- Size 1, 2, 3, 4, and 5 series - four rotor clearance bands:
 - (a) Standard
 - (b) FF (Front Face)
 - (c) Hot
 - (d) Chocolate (High Viscosity)

The pump should not be subjected to sudden temperature changes to avoid the risk of damage from sudden expansion/contraction of components. Care should be taken when selecting pumps for handling liquids containing abrasive particles as these may cause wear of pump head components.

Revolution Series	Operating Temperature Limit °C (°F)			
	Standard	FF	Hot	Chocolate
Circumferential Piston	93°C (200°F)	105°C (221°F)	150°C (302°F)	Refer to WFT

N/A = Not Available

Fig 6

Size	Pump Type	Model	Port Size	Optional Port Size	Max RPM	l/rev	USG/rev	Bar	PSI	m3/hr	USG/min
Size 2	CPP	R0150X	1.5	1	800	0.055	0.015	21	305	2.6	11.6
	RLP	R0150X	1.5	1	1000	0.061	0.016	15	218	3.6	16
	RLP	R0160L	1.5	1	1000	0.081	0.021	10	145	4.9	21.4
	CPP	R0180P	1.5	2	800	0.11	0.029	14	203	5.3	23.2
	RLP	R0180L	1.5	2	1000	0.11	0.029	7	102	6.6	29.1
Size 3	CPP	R0200X	1.5	2	800	0.16	0.04	21	305	8	34
	RLP	R0200X	1.5	2	1000	0.18	0.05	14	203	11	47
	CPP	R0300X	1.5	2	800	0.23	0.06	17	247	11	48
	RLP	R0300X	1.5	2	1000	0.25	0.07	9	131	15	66
	CPP	R0400X	2		800	0.29	0.08	14	203	14	62
	RLP	R0400X	2		1000	0.33	0.09	7	102	20	86
Size 4	CPP	R0450X	2	2.5	600	0.42	0.11	31	450	15	67
	RLP	R0450X	2		800	0.45	0.12	15	218	22	95
	CPP	R0600P	2.5	3	600	0.58	0.15	21	305	21	92
	CPP	R0800X	2.5	3	600	0.77	0.20	17	247	28	122
	RLP	R0800X	2.5	3	800	0.82	0.22	9	131	39	173
	CPP	R1300X	3		600	1	0.26	14	203	36	159
	RLP	R1300X	3		800	1.07	0.28	7	102	51	226
Size 5	CPP	R1800X	3		600	1.46	0.39	31	450	53	231
	CPP	R1830X	3		600	1.46	0.39	31	450	53	231
	RLP	R1800X	3		600	1.55	0.41	15	218	56	246
	CPP	R2200X	4		600	1.98	0.52	21	305	71	313
	CPP	R2230X	4		600	1.98	0.52	21	305	71	313
	RLP	R2200X	4		600	2.1	0.55	8	116	76	333
	CPP	R2600P	4		600	2.52	0.67	14	203	91	399
	CPP	R2630P	4		600	2.52	0.67	14	203	91	399

3.4 System Design.

3.4.1 System Design and Installation.

When incorporating any pump into a system it is considered good practice to minimize piping runs and the number of pipe fittings (tees, unions, bends etc.) and restrictions. Particular care should be taken in designing the suction line, which should be as short and straight as possible with a minimum of pipe fittings to minimise restricting product flow to the pump. The following should be considered at the design stage of any system.



Be sure ample room is provided around the pump to allow for:

- Access to the pump and drive for routine inspection and maintenance, i.e. to remove pump front cover and rotors.
- Ventilation of the drive to prevent overheating.



The exterior of the pump unit may exceed 68°C (154°F), Appropriate measures must be taken to warn or protect operators.

WARNING

The pump must not be used to support piping. All piping to and from the pump unit must be independently supported. Failure to observe this may distort the pump head components or assembly and cause serious consequential damage to the pump.

Valves should be provided adjacent to the pump suction and discharge connections to allow the pump to be isolated from the system for routine inspection and maintenance.



Circumferential piston and rotary lobe pumps are of the positive displacement type and therefore an overload protection device must be provided. This can take the form of:

- An in-line pressure relief system, i.e. external to the pump.
- Incorporation of a torque-limiting device in the drive system.

WARNING

It is recommended that all piping and associated equipment from the tank to the discharge point is thoroughly cleaned before installation of the pump to avoid the possibility of debris entering the pump and causing damage.

WARNING

Pressure gauges should be installed adjacent to the pump suction and discharge connections such that system pressures can be monitored. These gauges will provide a clear indication of changes in operating conditions and where a relief valve is incorporated in the system, will be necessary for setting and checking the functioning of the valve.

WARNING

It is imperative that the suction condition at the pump inlet meets the Net Positive Suction Head required (NPSHr) by the pump. Failure to observe this could cause cavitation, resulting in noisy operation, reduction in flow rate and mechanical damage to the pump and associated equipment.

WARNING

The Net Positive Suction Head available (NPSHa) from the system must always exceed the Net Positive Suction Head required (NPSHr) by the pump.

Observing the following general guidelines should ensure the best possible suction condition is created.

- Suction piping is at least the same diameter as the pump connections.
- The length of suction piping is kept to the absolute minimum.
- The minimum number of bends, tees and pipework restrictions are used.
- Calculations to determine system NPSHa are carried out for the worst condition, see below.

Should advice on pump or system NPSH characteristics be required contact the factory or their authorised distributor.

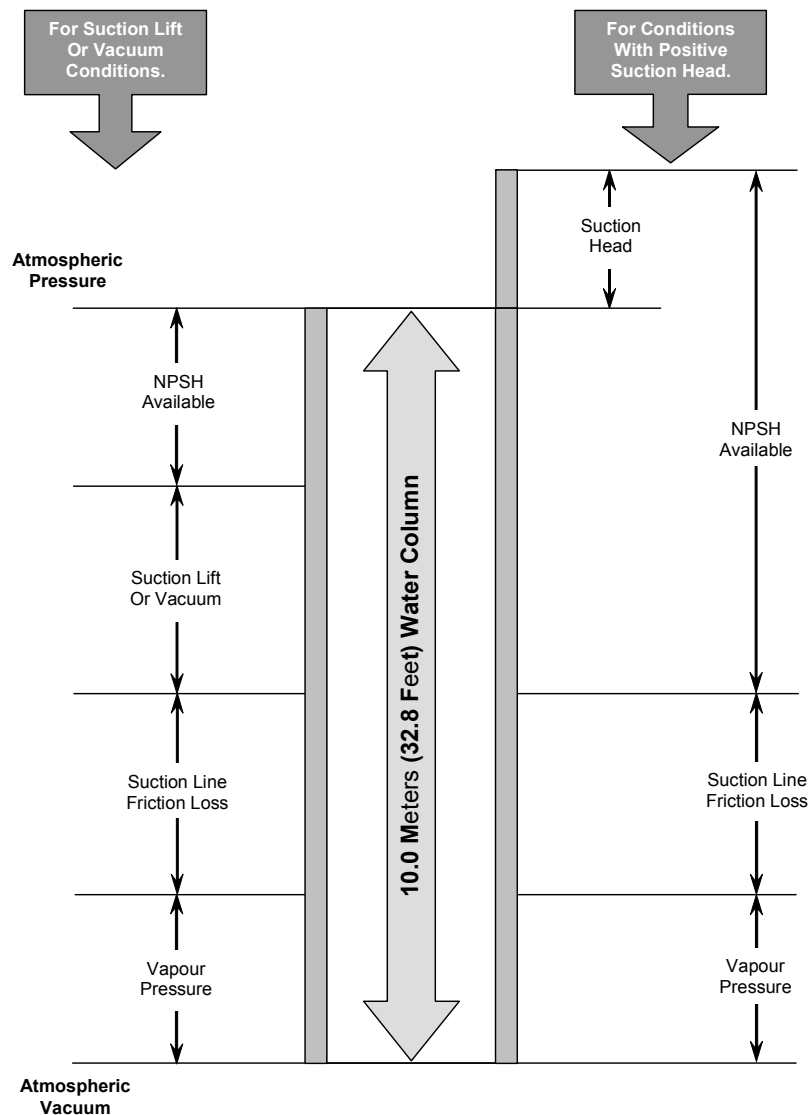

Fig 7

When installing a pump complete with base plate, motor and drive, the following guidelines must be observed:

- a) The preferred drive arrangement for any circumferential piston or rotary lobe pump is in-line direct coupled. If an alternative is required please contact Wright Flow Technologies or your Wright Flow Technologies distributor.



- b) Flexible couplings must always be incorporated and correctly aligned within the limits recommended by the coupling manufacturer. To check coupling alignment rotate the shaft by at least one full revolution and ensure that the shaft rotates smoothly.

Couplings of a non-flexible design must never be used.



- c) Couplings must always be enclosed in a suitable guard to prevent contact with rotating parts, which could result in personal injury. Guards should be of suitable material, (see d) and of sufficiently rigid design to prevent contact with rotating parts under normal operating conditions.



- d) When the pump is installed in a flammable or explosive environment, or is used for handling flammable or explosive materials, special consideration must be given. Not only to the safety aspects of the drive unit enclosure but also to the materials used for both the coupling and the guard to eliminate the risk of explosion.



- e) Base plates must be secured to a flat level surface such that distortion and misalignment are avoided. Once base plates are fastened in position the drive alignment must be re-checked, (see b).

- f) When using electric motor drives, ensure that the electrical supply is compatible with the drive and controls and that the method of wiring is correct for the type of starting required by the motor i.e. Direct On Line, or other similar method. Ensure all components are correctly grounded.

3.4.2 Installations with CIP Systems.

The Revolution pump range is designed to be effectively cleaned by the CIP procedures recommended for in place cleaning of process plant. It is recommended that a differential pressure of 2 to 3 Bar (30 to 45 psi) be developed across the pump head during cleaning in order to develop the necessary fluid velocities required for thorough cleaning.

To assist in maximizing the effectiveness of cleaning within the pump head, it is recommended that during the cleaning cycle a flow rate equivalent to a velocity of 1.5 metres per second in a pipe of equal diameter to the rotor case connections is achieved. In a pump with a 2.5 inch port, this means 300 liters per minute (for the R800)

We also recommend rotating the pump during the CIP cycle to help the flow enter all cavities

3.5 Start Up Procedure.

WARNING

- Check that all piping and associated equipment are clean and free from debris and that all pipe connections are secure and leak free.

WARNING

- For pumps fitted with flushed product seals check all auxiliary services are in place and connected and provide sufficient flow and pressure for flushing purposes.

WARNING

- Ensure lubrication is provided for both pump and drive. The Revolution can be shipped with different lubrications see section 6.3 for capacities and grades.

WARNING

- If an external relief valve is incorporated in the system, check that it is set correctly. For start up purposes, it is considered good practice to set the relief valve lower than the system design pressure. On completion of start up, the relief valve should be reset to the required setting for the application. The required setting should never exceed the lower of either the pumps maximum pressure rating or the system design pressure.

WARNING

- Be sure both suction and discharge valves are fully opened and that pipe work is free from all obstructions. The Revolution is a positive displacement type pump and should therefore never be operated against a closed valve as this would result in pressure overload, resulting in damage to the pump and possibly the system.

WARNING

- Make sure that the drive shaft rotation is correct for the direction of flow required. See Fig 8.

Fig 8

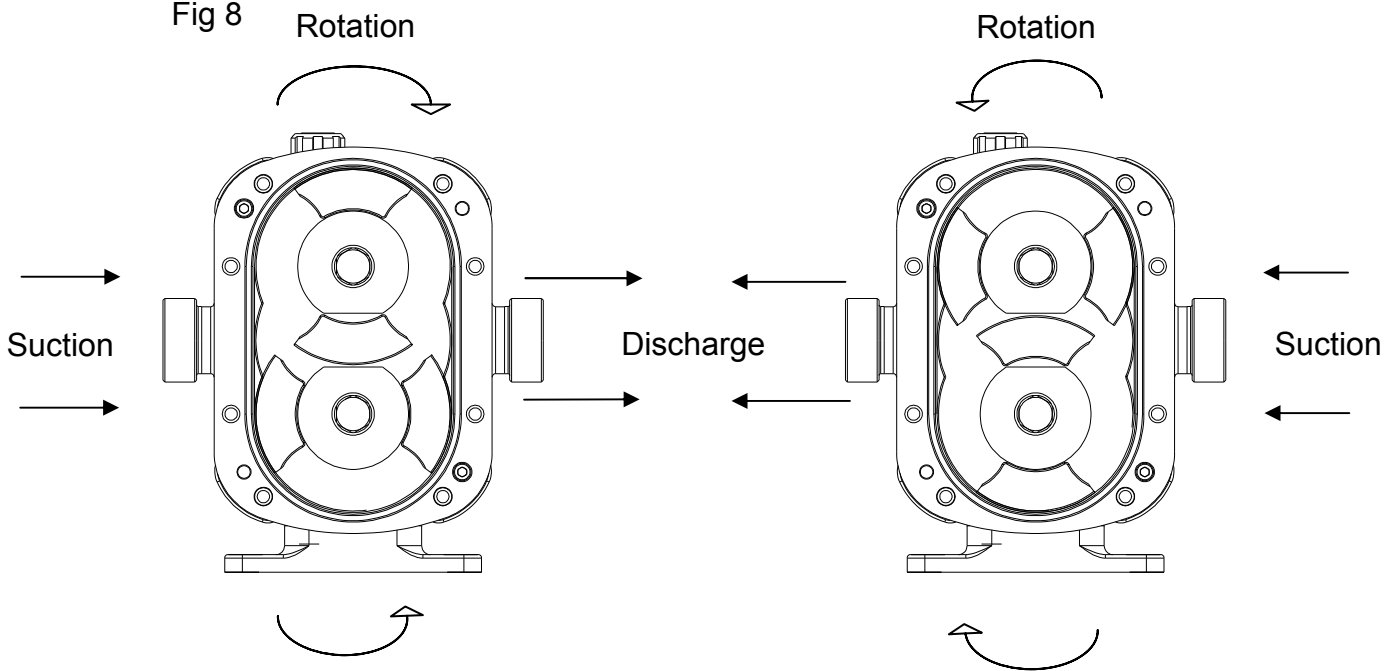

WARNING

- Be sure product is available in the suction vessel before starting the pump. This is very important for pumps fitted with un-flushed product seals, as these sealing arrangements must never be allowed to run dry.
- Before beginning operation, it is considered good practice to momentarily start/stop the pump to check the direction of rotation and ensure that the pump is free of obstructions. Once this has been carried out, begin operation keeping a visual check on suction and discharge pressure gauges and monitor the pump temperature and absorbed power where possible.

3.6 Shutdown Procedure.



When shutting the pump down, stop pump, close both the suction and discharge valves and ensure that the necessary safety precautions are taken:

- The prime mover power source has been isolated.
- If installed, pneumatically operated integral relief valve has been depressurised.
- Flushed product seal auxiliary services have been isolated and depressurised.
- Pump head and piping have been drained and purged.
- Before undertaking any work on the pump refer to sections 4, 5, and 6.

3.7 Routine Maintenance.

Oil

WARNING

- Check oil levels regularly.
- Change the oil every 12 months or 3000 operating hours, whichever is the sooner.

Grease

- Low maintenance gearbox, factory filled with EP 00 semi-fluid grease. The grease should not require replacement during the lifetime of the bearings or until 20,000 hours of operation.

For lubricant capacities and grades refer to section 6.3.

Seal Replacement Interval:

It is recommended that the Rotor Retainer o-ring seal be replaced every 12 months to maintain a bacteria tight seal.

Rotor Retainer Seal Inspection:

Periodically inspect the Rotor Retainer o-ring seal for any discoloration, nicks, or cracks. If any of the defects above are noticed, the o-ring seal must be replaced. Inspection and replacement refer to the seal replacement procedure below.

Seal Replacement Procedure:

1. Remove the Front Cover (see section 4.1)
2. Loosen Rotor Retainers and ensure components are dry before servicing.
3. With a penlight, inspect Rotor Retainer blind tapped hole for contamination. If soiled, refer to cleaning procedure below
4. Remove and discard Rotor Retainer o-ring seal.
5. Install new Rotor Retainer o-ring seal.
6. Install Rotor Retainer and use a torque wrench to tighten to correct torque (see section 6.2)
7. Install the Front Cover and torque up the Dome Nuts – (see section 6.2).

Cleaning Procedure for Soiled Retainer Screw Tapped Hole:

1. Remove Rotor Retainer from the shaft.
2. Submerge and soak retainer for 5 minutes in Clean Out of Place tank with appropriate / compatible cleaning solution
3. Scrub both external and internal threads vigorously with appropriate bristle brush and appropriate / compatible cleaning solution
4. Rinse well with clean water and dry blind tapped hole with clean air.

Should debris remain, or time is of the essence, install a new (spare) Rotor Retainer.

3.8 Flushing Positions Size 2,3,4

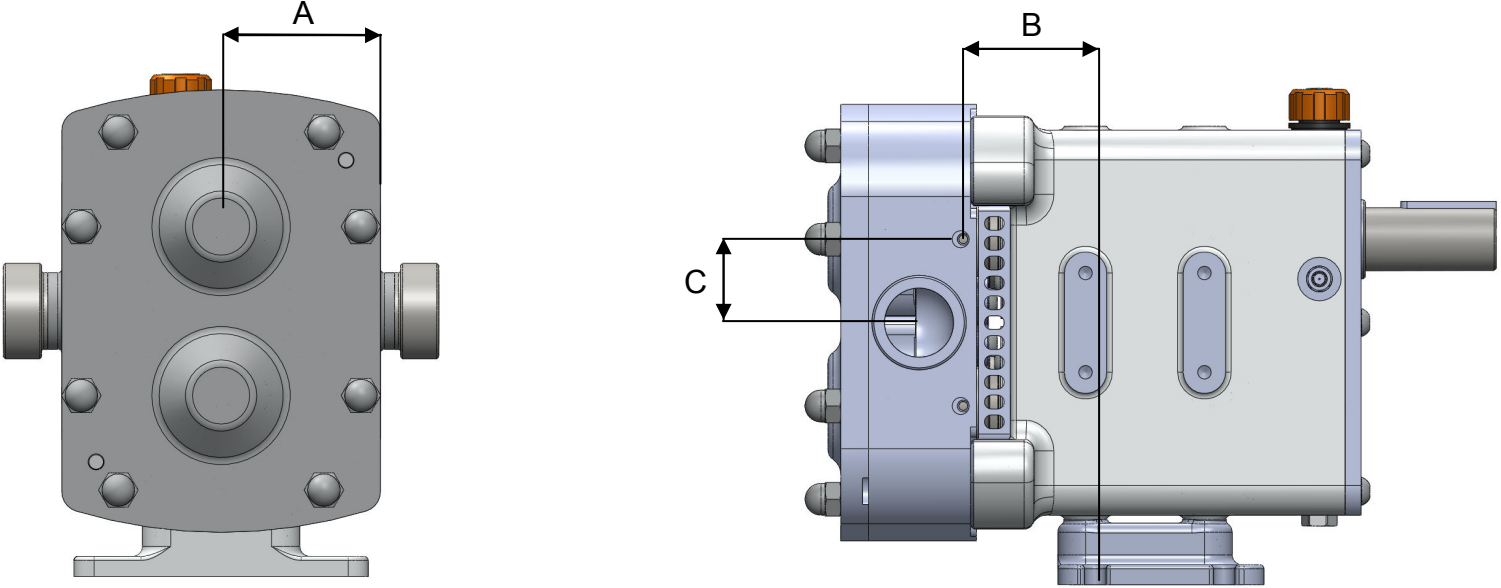

The above diagram shows the positions for flushing the Revolution size 2,3 and 4 range of pumps

	A		B		C		Connection
	MM	Inch	MM	Inch	MM	Inch	
Size 2	62	2.44	79	3.11	107	4.21	1/8" BSP
Size 3	58	2.28	68	2.68	97.5	3.84	1/8" BSP
Size 4	32.5	1.28	42	1.65	57	2.24	1/8" BSP

3.8.1 Flushing Positions Size 5

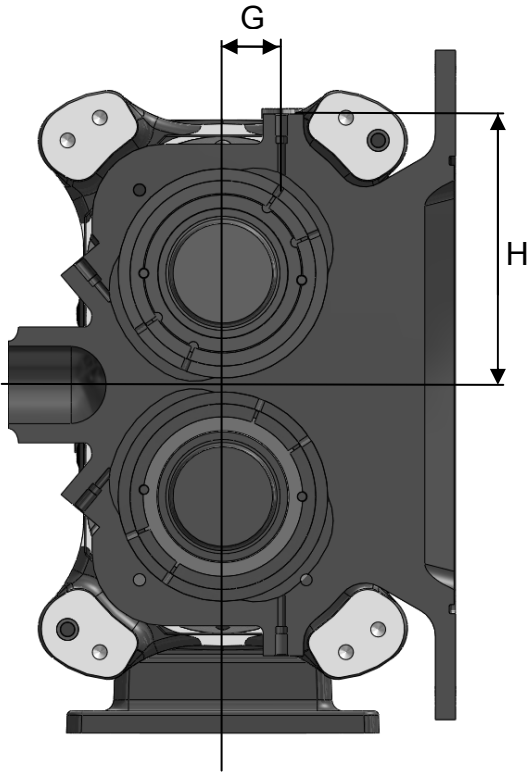

Rectangular / Hopper Arrangement

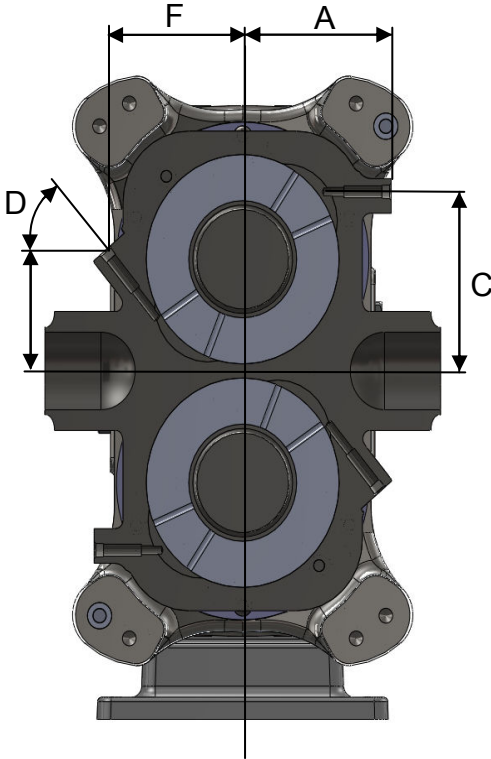

Standard Ports Arrangement

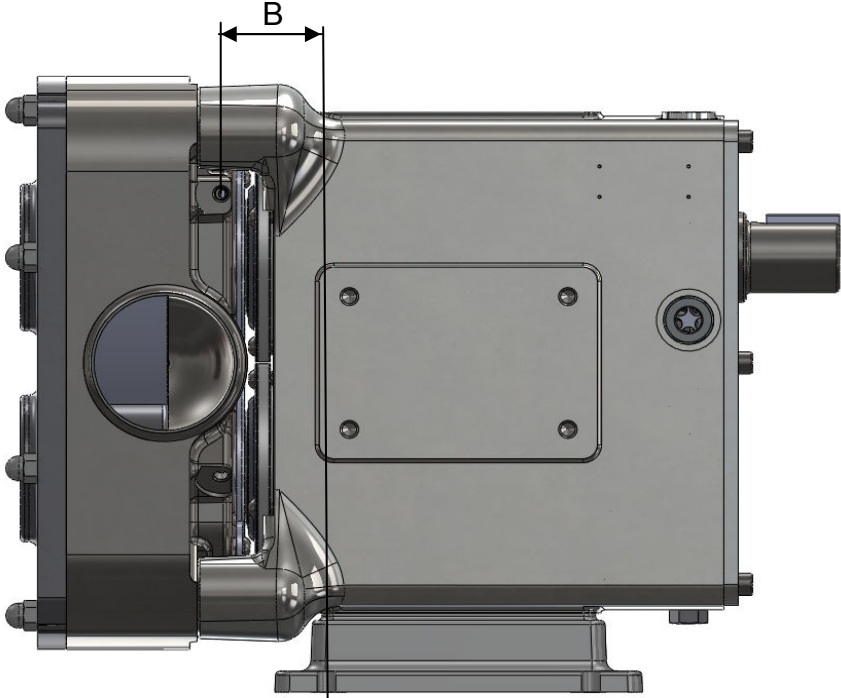

	A		B		C		D	E		F		G		H		Connection
	MM	Inch	MM	Inch	MM	Inch	Degrees	MM	Inch	MM	Inch	MM	Inch	MM	Inch	
Size 5	110	4.33	42	1.65	122.2	4.81	50	82	3.23	102	4.02	9.8	0.39	136.7	5.38	1/8" BSP

3.8.2 Recommended Flush Circulation.

Horizontal Port Straight Flush

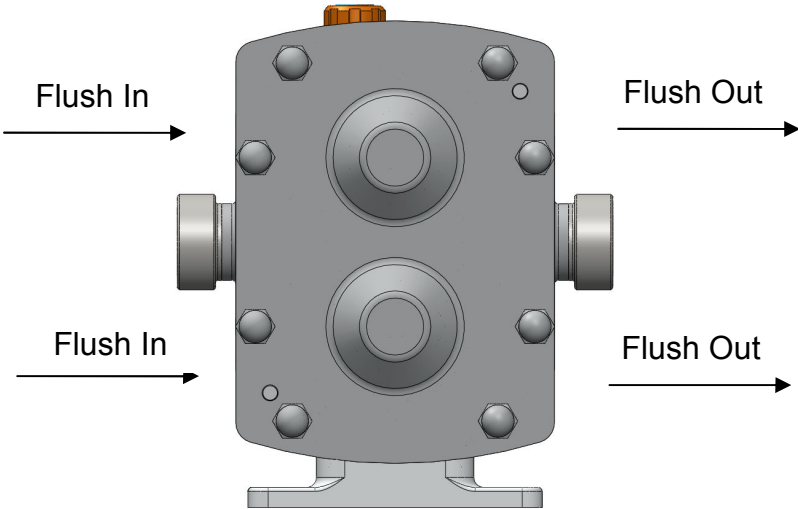

Horizontal Circular Flush

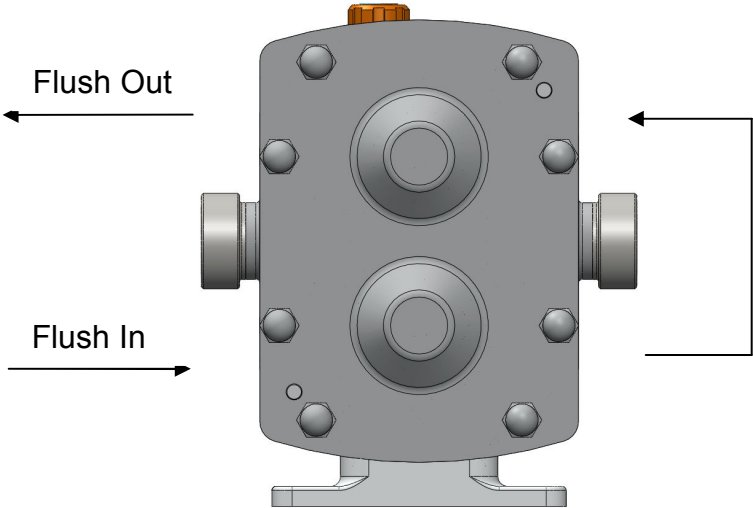

Note: The liquid supply connections to flushed seals are made using the threaded ports on the sides of the rotorcase. The pipe work should be arranged to provide an independent flush to each seal.

Vertical Straight Flush

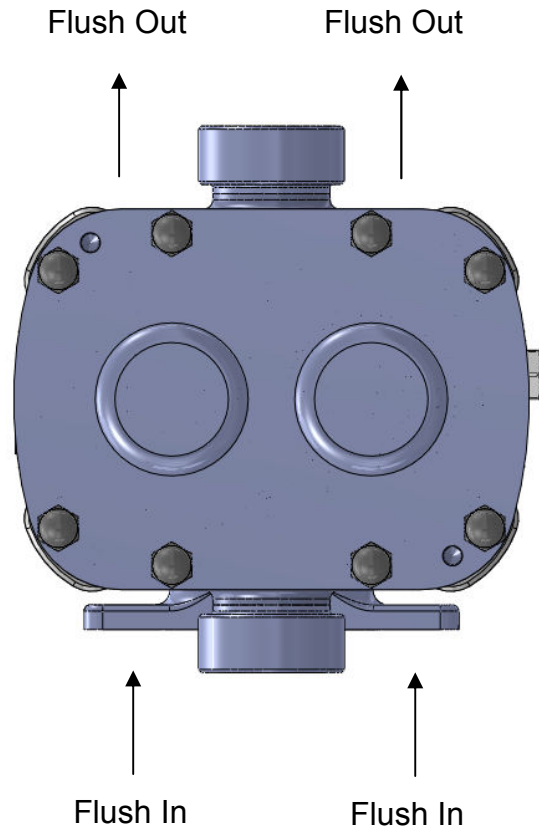

Vertical Circular Flush

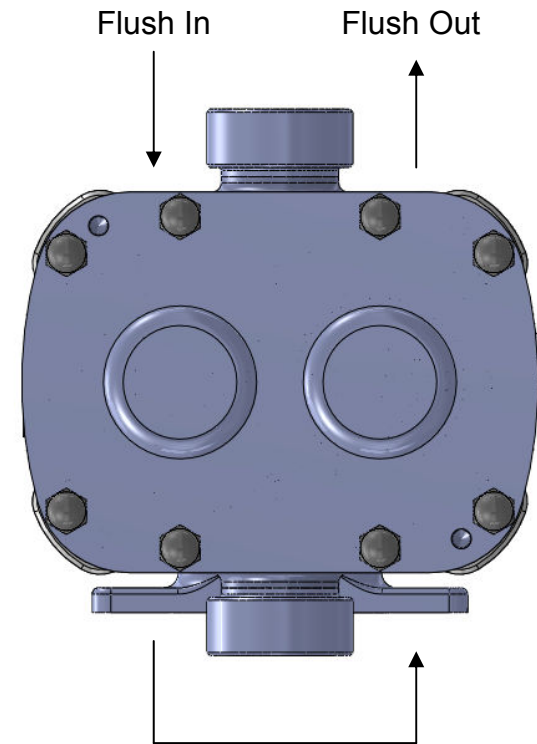

Note: The liquid supply connections to flushed seals are made using the threaded ports on the sides of the rotorcase. The pipe work should be arranged to provide an independent flush to each seal.

3.8 Heating / Cooling.

The Revolution range of pumps can be supplied with heating / cooling jackets – these jackets will be a bolt on addition and use FDA thermal paste to ensure a good heat / cool transition.

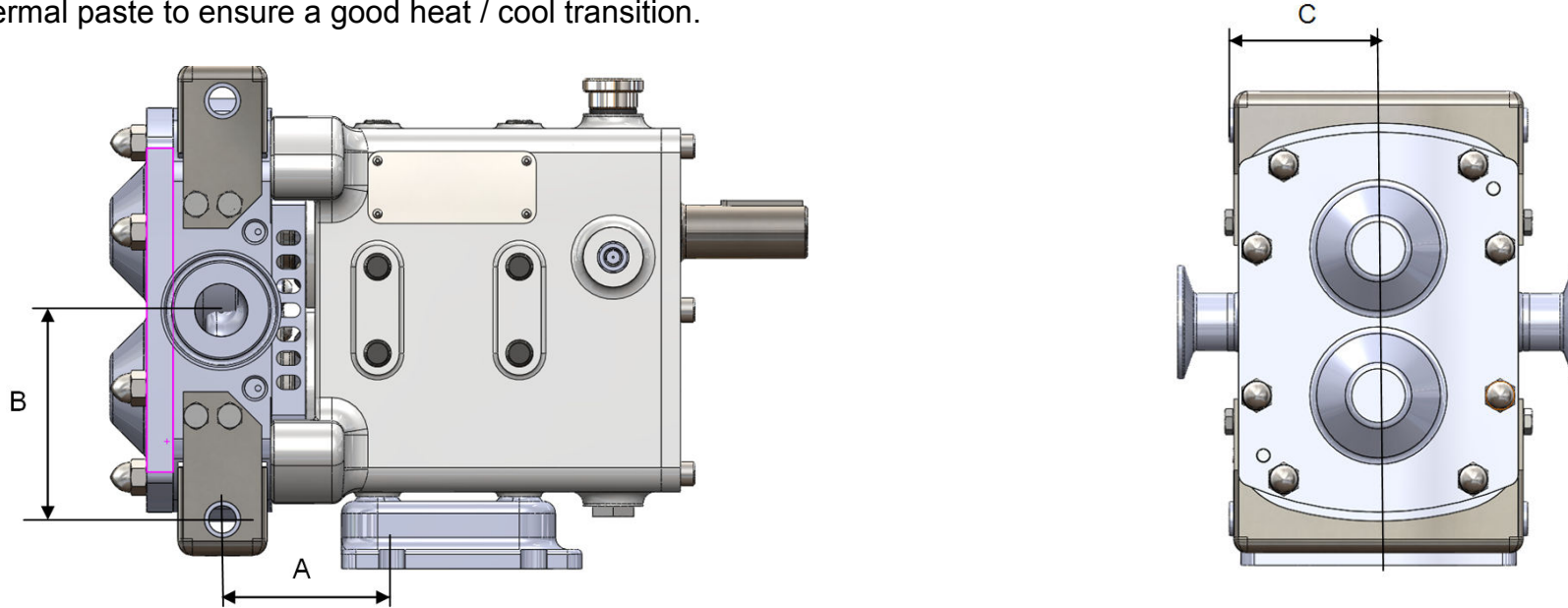

		Size 2				Size 3			Size 4				Size 5		
		R0150X	R0160L	R0180X	R0180L	R0200	R0300	R0400	R0450	R0600	R0800	R1300	R1800	R2200	R2600
A	mm	70.5	75	84	81.5	90.5	100.5	110.5	121	131	143	158	128.5	146.5	165.5
	Inch	2.78	2.95	3.31	3.21	3.56	3.96	4.35	4.76	5.16	5.63	6.22	5.06	5.77	6.52
B	mm	87				114			159				217		
	Inch	3.43				4.49			6.26				8.54		
C	mm	64.5				81			109				142		
	Inch	2.54				3.19			4.29				5.59		
Size		1/4" bsp				1/4" bsp			1/2" bsp				1/2" bsp		

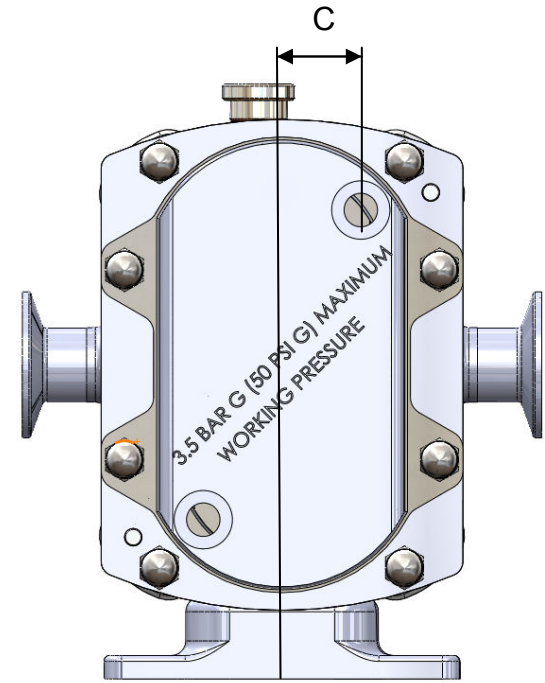
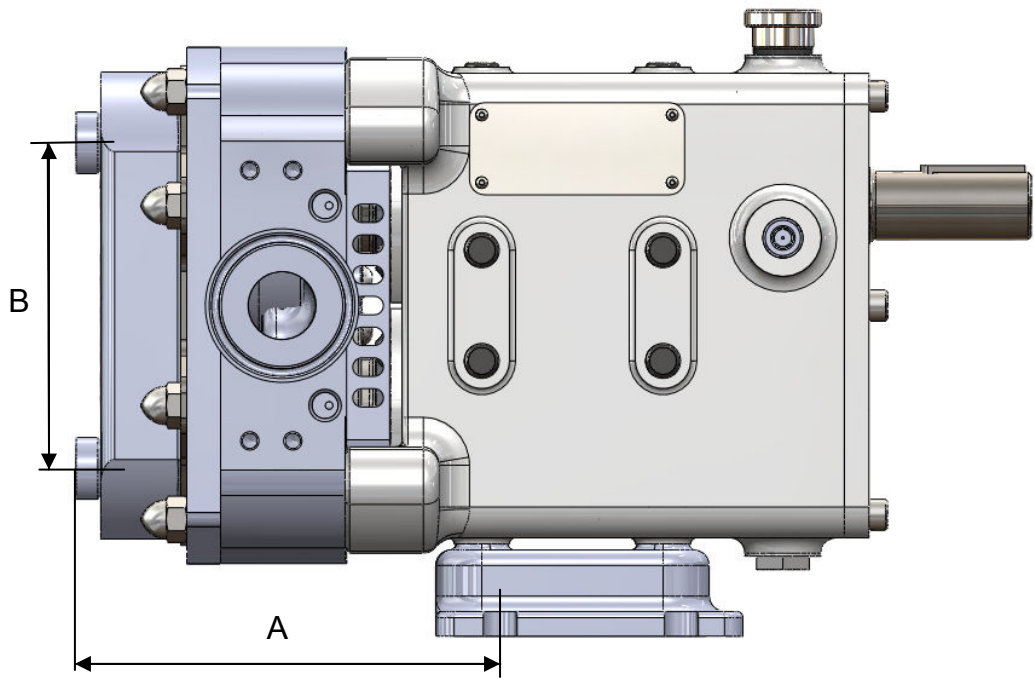

		Size 2				Size 3			Size 4				Size 5		
		R0150X	R0160L	R0180X	R0180L	R0200	R0300	R0400	R0450	R0600	R0800	R1300	R1800	R2200	R2600
A	mm	138	142.5	151.5	149	166.5	176.5	186.5	210	220	232	247	232	250	269
	Inch	5.43	5.61	5.96	5.87	6.56	6.95	7.34	8.27	8.66	9.13	9.72	9.13	9.84	10.59
B	mm	106				132			180				260		
	Inch	4.17				5.2			7.09				10.24		
C	mm	27				35			52				60		
	Inch	1.06				1.38			2.05				2.36		
Size		1/4" bsp				1/4" bsp			1/2" bsp				1/2" bsp		

3.8.1 Rotorcase Heating Jacket installation

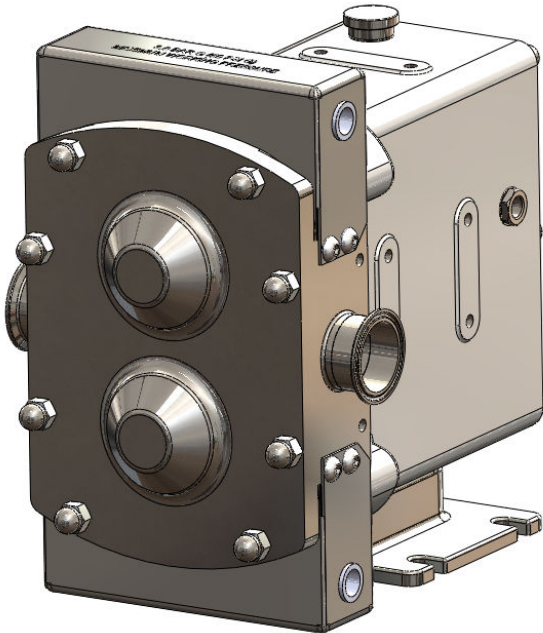

Apply the heat transfer paste to the underside of the bolt on Jacket (see below)

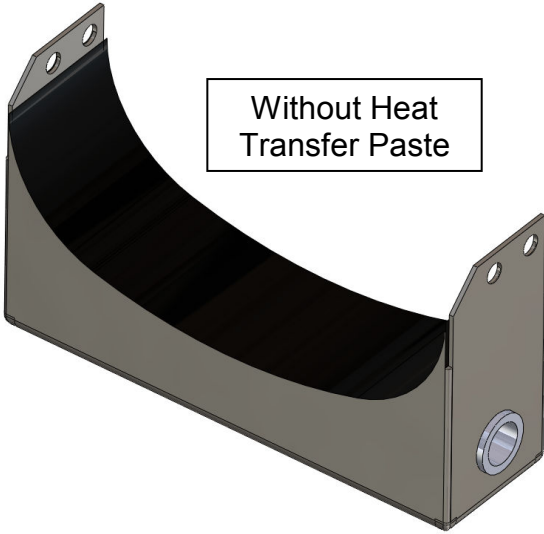

Without Heat Transfer Paste

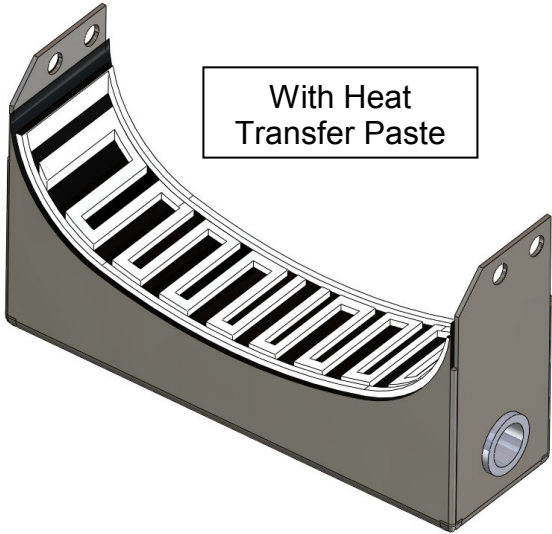

With Heat Transfer Paste

Frame Size	Heat Transfer Paste
2	2cc (0.067oz)
3	3cc (0.101 oz)
4	6cc (0.202 oz)
5	7cc (0.236 oz)

Fit the jacket onto the Rotorcase.

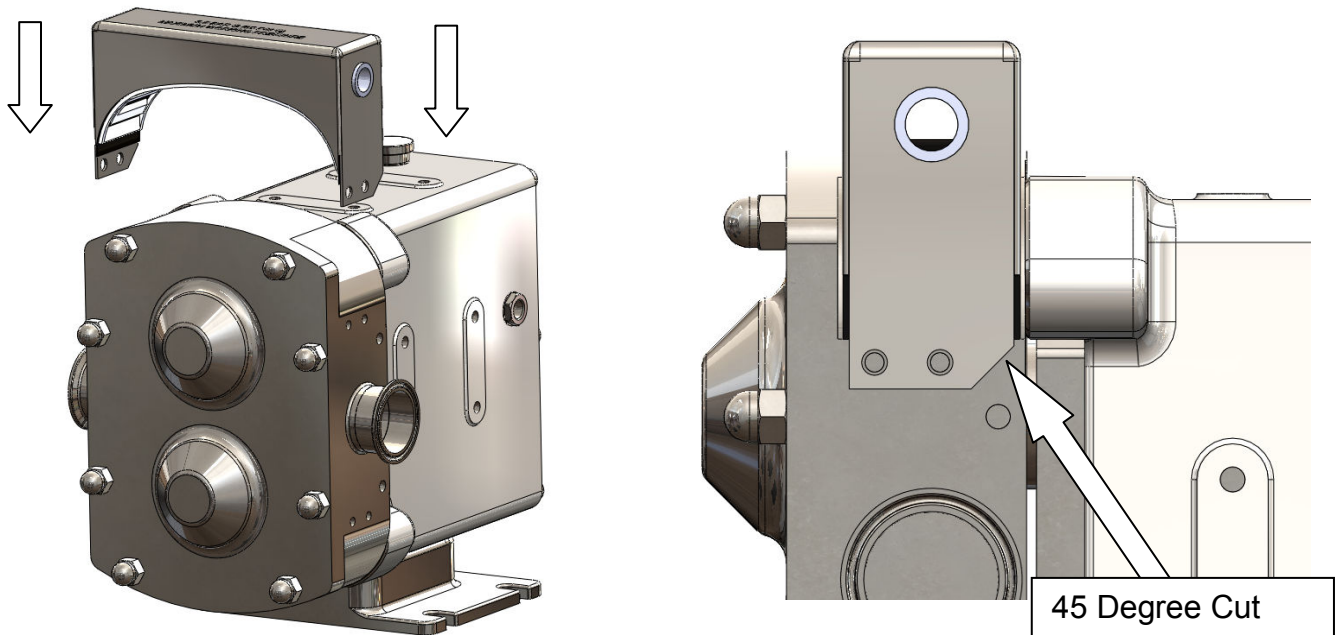

Note the 45 degree cutout faces the rear of the Rotorcase and allows clearance on the flushing holes

Secure the jacket onto the Rotorcase using the washers and the screws
(Wipe away any extra heat transfer paste that is extruded)

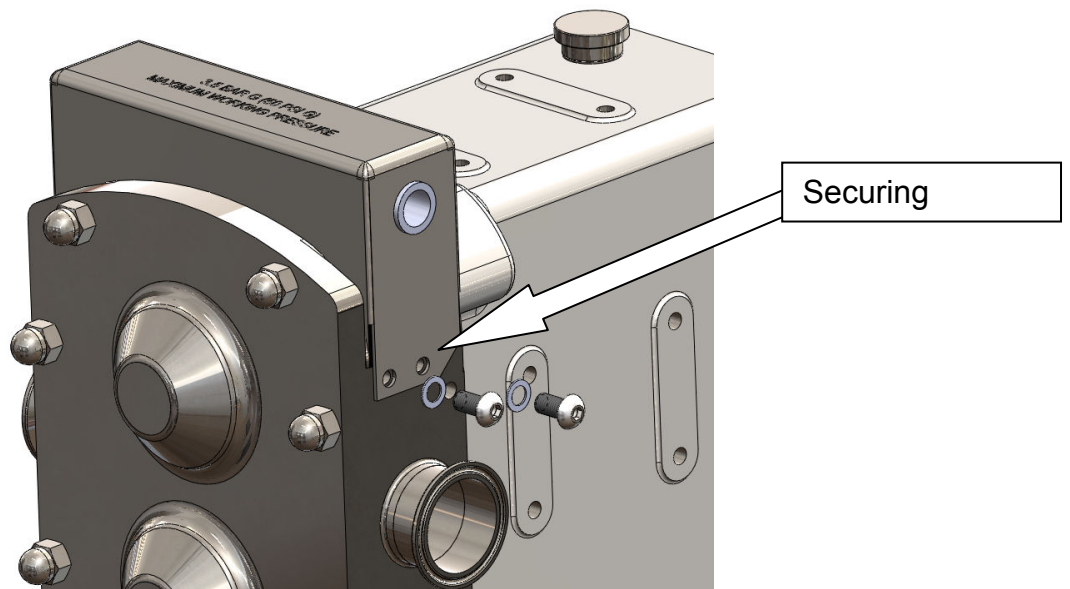

3.8.2 Front Cover Heating Jacket installation

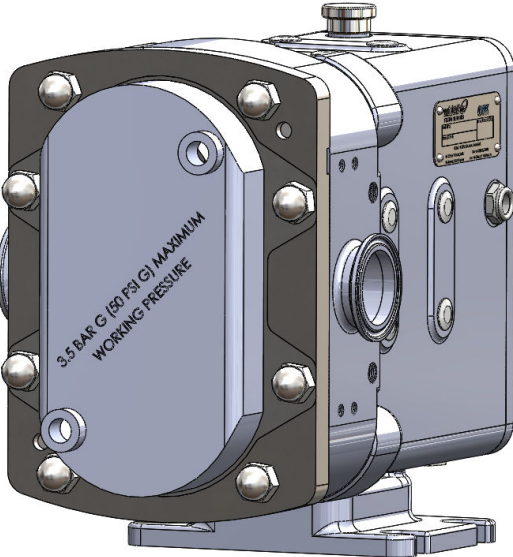

Apply the heat transfer paste to the underside of the bolt on Jacket (see below)

Without Heat Transfer Paste

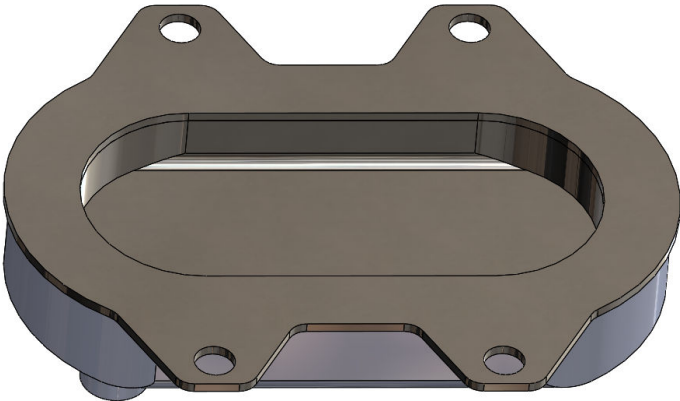

With Heat Transfer Paste

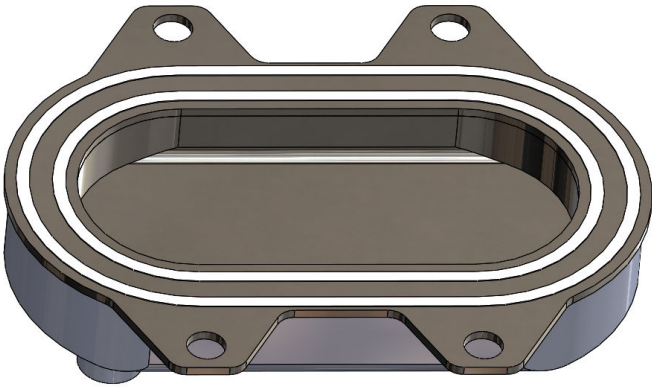

Frame Size	Heat Transfer Paste
2	0.7cc (0.024oz)
3	1.3cc (0.045 oz)
4	2.2cc (0.077 oz)
5	5.5cc (0.193 oz)

Fit the jacket onto the Front Cover.

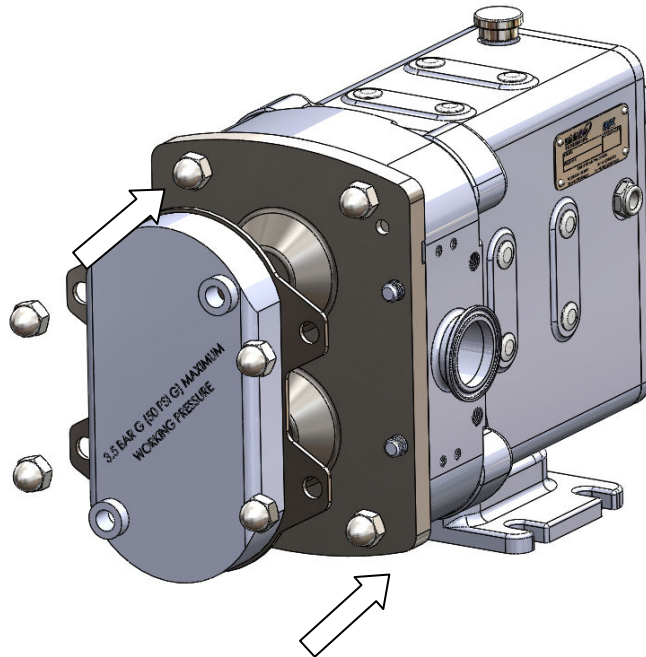

Secure the jacket onto the Front Cover using the dome nuts (Wipe away any extra heat transfer paste that is extruded)

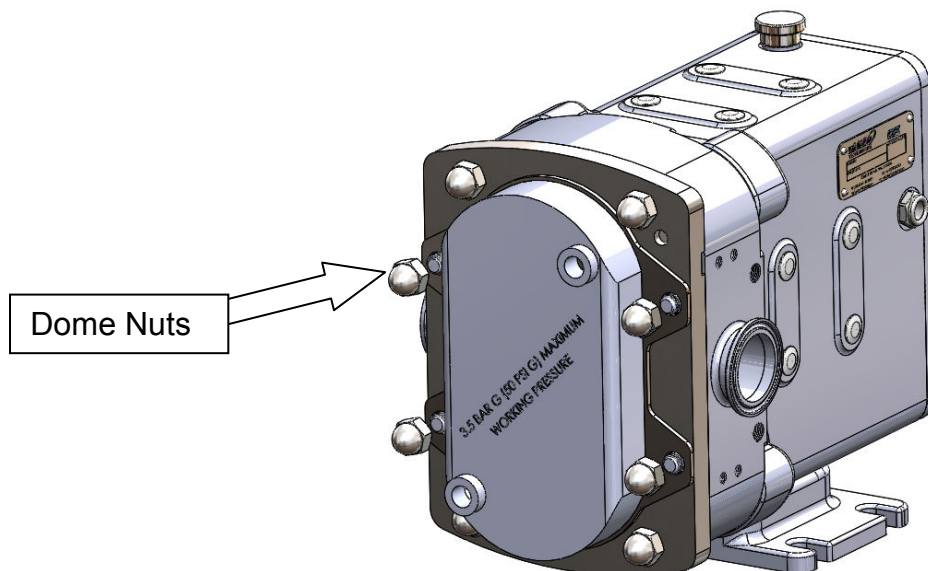

4.0 Revolution Disassembly and Assembly.



Before starting any work on the pump the recommended Shutdown Procedure should be followed, refer to section 3.6.



While disassembling or assembling the pump it is essential to ensure that the pump and/or components are secured to provide adequate stability.



Large pump components or sub-assemblies should be installed using suitable devices. Use threaded holes for the attachment of lifting eyes where appropriate.

During disassembly or before assembly, all components should be inspected for fit, wear and damage. If worn or damaged the components should be replaced.

The position of all parts should be identified as they are removed to ensure they are reinstalled in the same position.

Lipseals and o-rings are incorporated within the gearbox assembly to contain the lubricant for the bearings and timing gears. Regular inspection and correct maintenance of these items will ensure that the lubrication is sustained and the pump maximum working life is achieved. To ensure this, it is extremely important that care is taken when removing and replacing new o-rings and lipseals. When removing and replacing lipseals ensure that the location bore for the outside diameter and the seat for the back of the lipseal is not damaged as this may create a leak path for the lubricant.

When removing lipseals or o-rings care should be taken to avoid cutting or tearing the sealing faces as they pass over keyways, splines, threads or other potentially sharp or abrasive edges. All lipseals and o-rings should be carefully examined and if damaged in any way, be replaced.

All o-rings and sealing lips of lipseals should be lightly lubricated with an appropriate lubricant (suitable for application) before installing.

When installing lipseals do not allow the rear face to come into contact with bearings or other rotating parts.

Prior to beginning assembly, ensure all parts are clean and free from burrs or damage. Where a vice is to be used then this should be installed with protective jaws to avoid damage to components. Do not hammer or apply undue force to install or position components.

WARNING

All fasteners are required to be tightened to the required torque setting during assembly, refer to section 6.2.



The preferred method of installing bearing cones is that they are heated to approximately 125°C (250°F) prior to installation. During this operation protective gloves should be used. Once bearing cones are installed in the correct position they should be allowed to cool before proceeding with assembly. As an alternative, bearing cones may be pressed into position providing the proper equipment is utilised and the necessary procedures are used to prevent component damage.

Under no circumstances should bearing cones or cups be hammered into position.

4.1 Disassembly.

4.1.1 Front Cover and Rotor Removal.

Fig 15

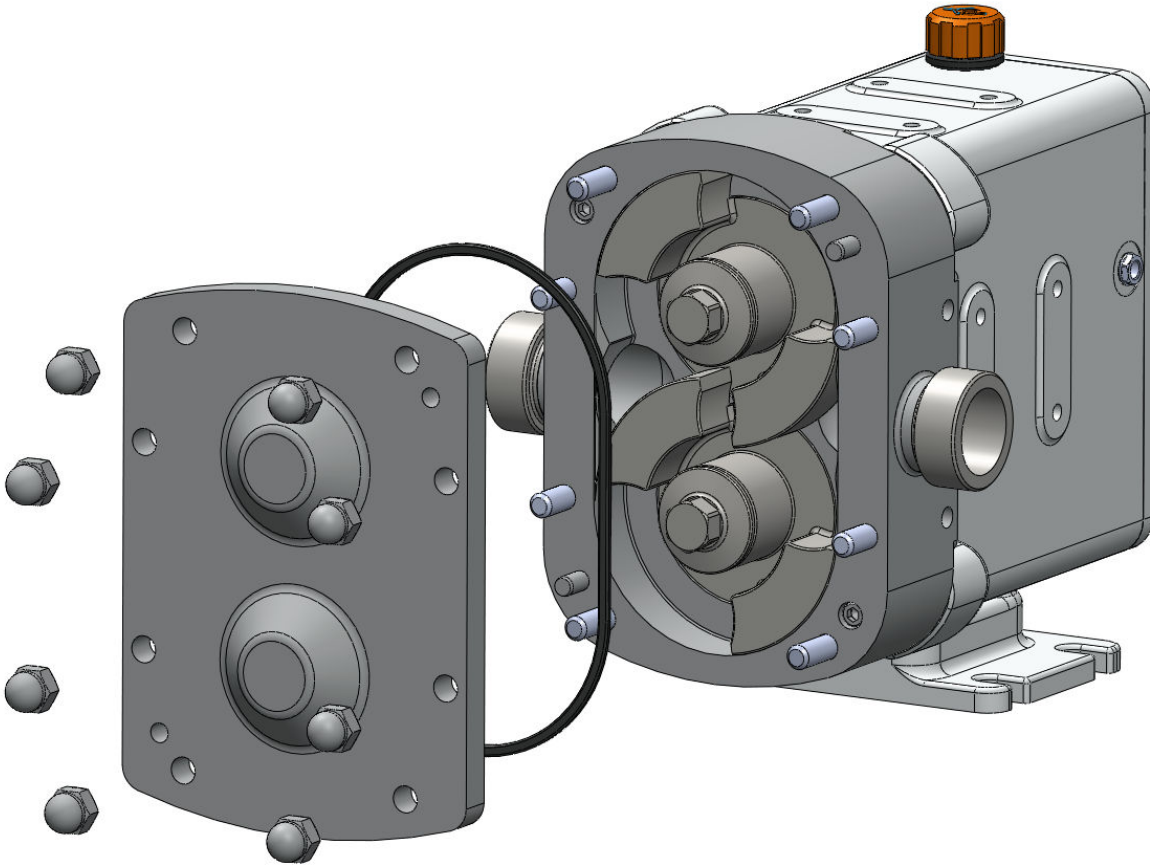

- Remove the front cover dome nuts.
- Remove the front cover and the front cover o-ring.
- Remove the rotors by unscrewing the rotor retainers; taking care not to damage the product seal components.



4.1.2 Rotorcase Removal.

Fig 16

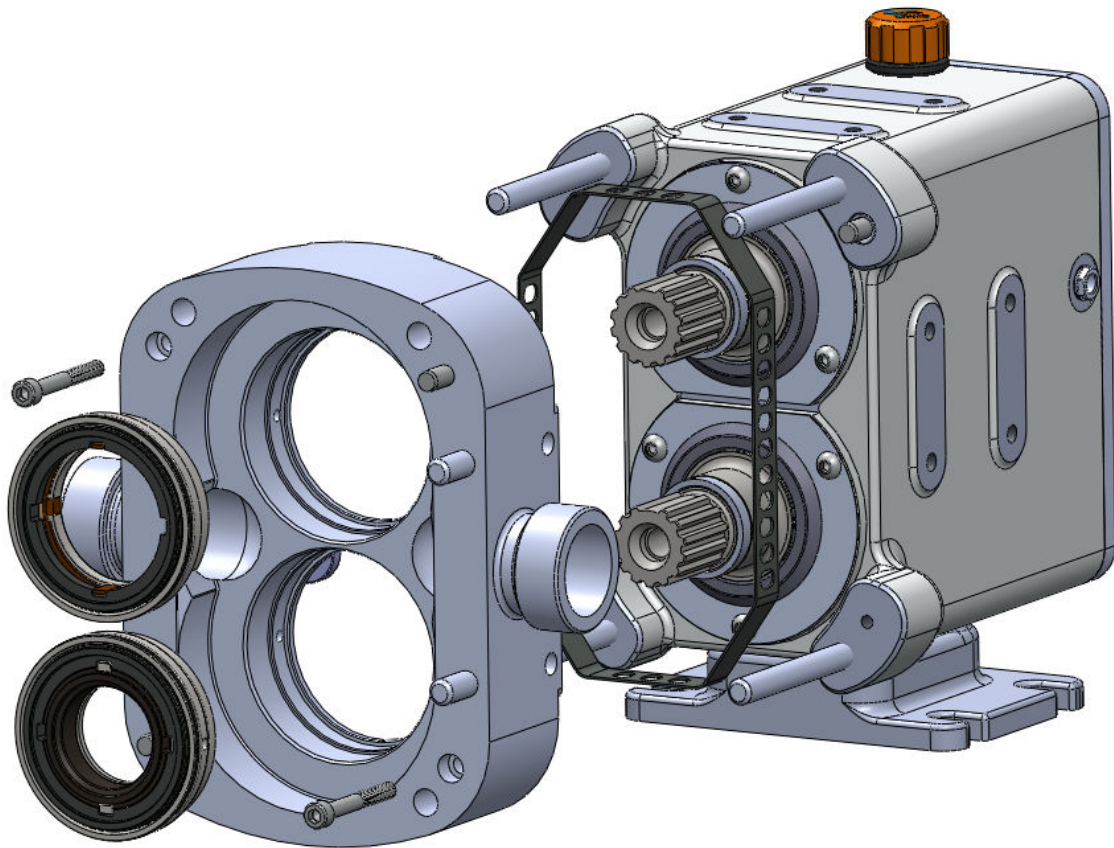

- Remove the seal housings making sure that the static face is not damaged.
- Remove the rotorcase retaining screws and then remove the rotorcase.
- Remove the guard.

4.1.3 Gearbox Disassembly.

Fig 17

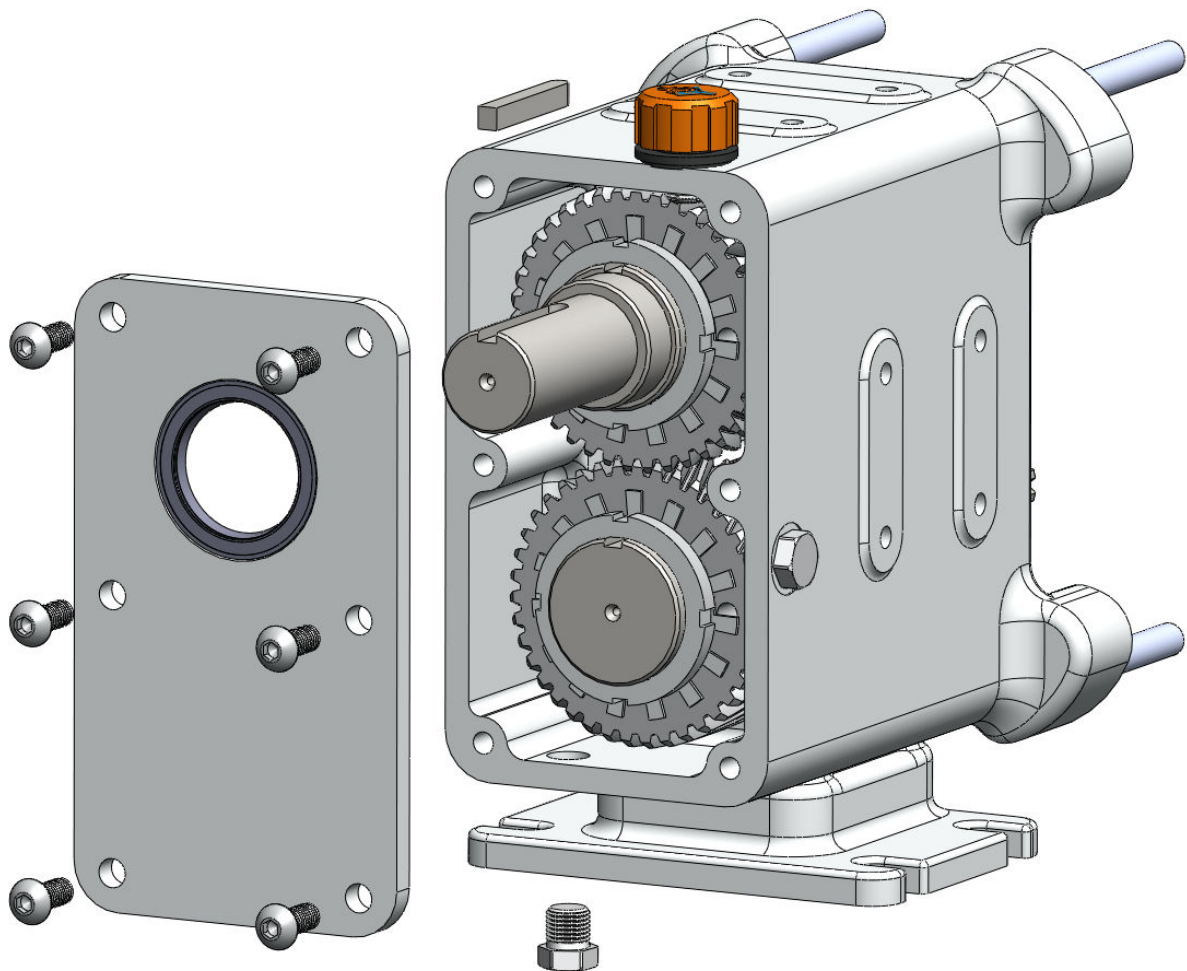

- Make sure the gearbox lubricant has drained by removing the drain plug.
- Remove the drive key.
- Remove the hexagon head bolts and remove the gearbox cover.



Note when removing the cover take care not do damage the lipseal on the keyway.

4.1.4 Gear removal.

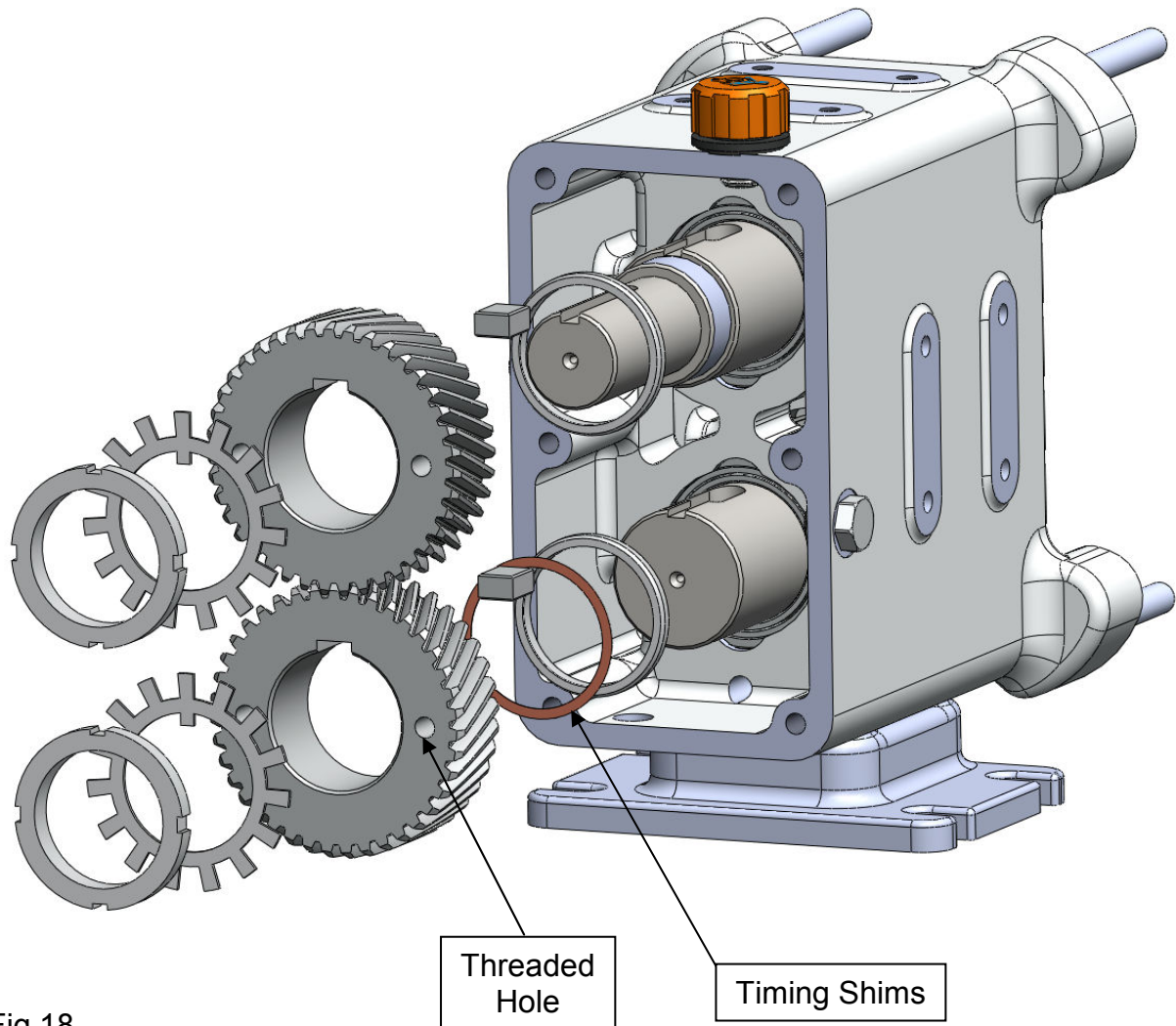

Fig 18

- Remove the lock nuts and tab washers.
- Remove the gears, the two threaded holes within the gears can be used to aid gear removal with a puller tool.



The two threaded holes are to be used only in conjunction with gear pullers – any other use will damage components.

- Remove the gear keys and the timing shims and then remove the gear spacer.

Note the above picture show the timing shims on the lay shaft, depending on how the unit is built they could be on the drive shaft.



Keep the locknut, tab washer, gear, key, shims and gear spacer in the sets that they were removed and identify them drive and lay.

4.1.5 Front Spacers and Lip-seals.

Fig 19

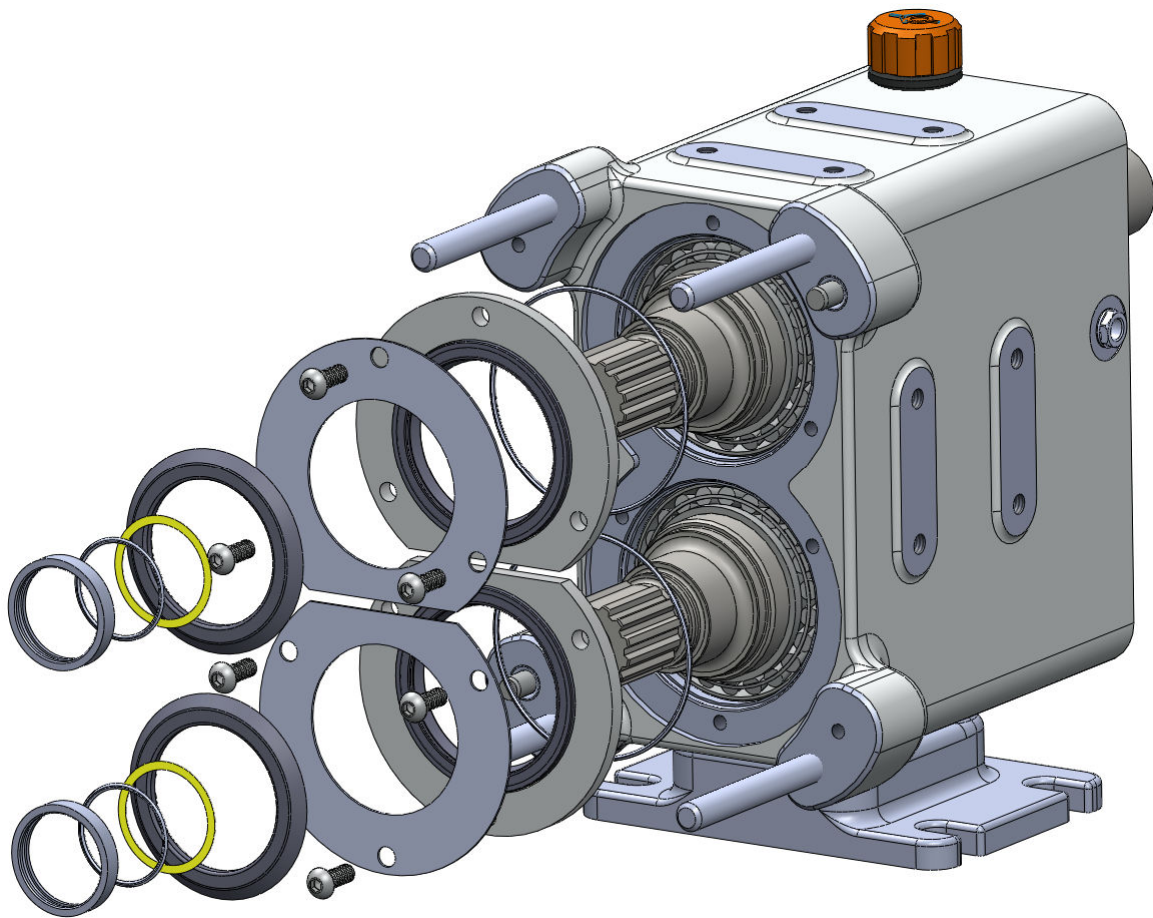

- Remove the front spacer ring, o-ring and shims.
Keep these in the sets that they were removed and identify them drive and lay.
- Remove the screws holding the lip seal carriers.
- Remove the optional gamma seal, counter face gamma seal, bearing retainer plate and the o-ring.



At this point the shafts are not held in place so take care when moving the gearbox.

4.1.6 Shaft and Bearing Removal.

Fig 20

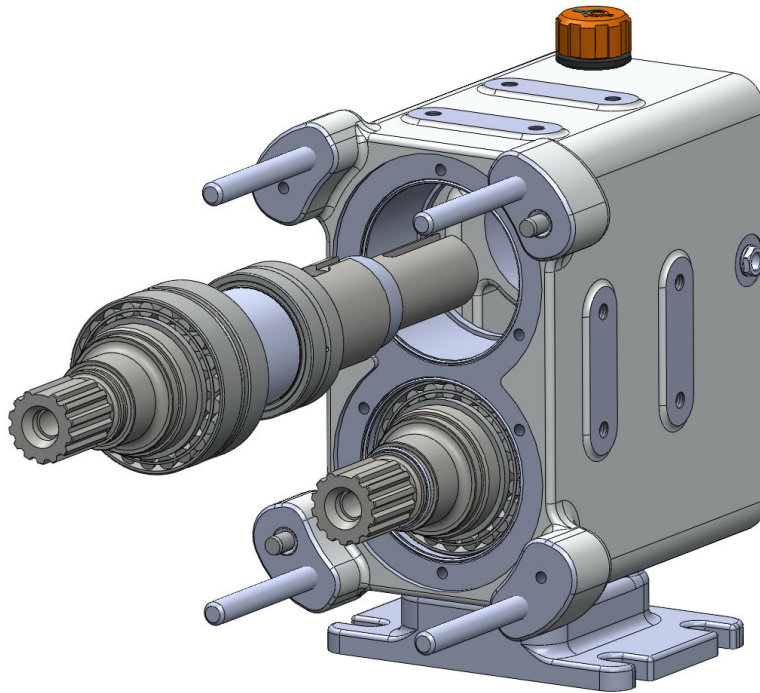

- Using a light press remove the shafts.

Fig 21

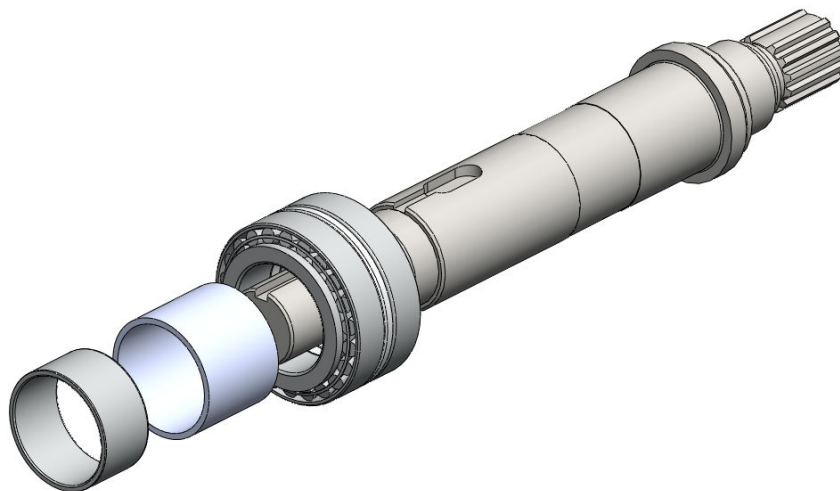

- Remove the bearings and spacer using a press.



Note some models may have two bearing spacers

4.2 Assembly.

4.2.1 Shaft Assembly.

Fig 22

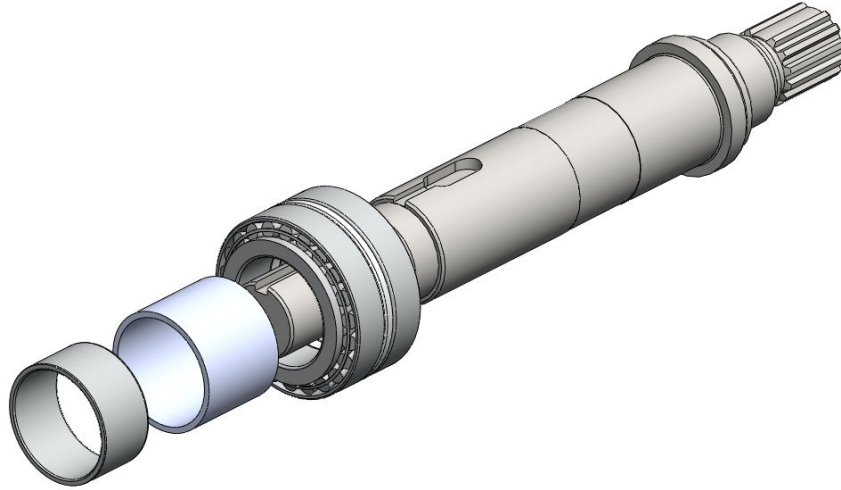

- The tapered roller bearings have matched pre-load spacers, these set the rolling torque and must be kept with the matching bearings.
- Using a bearing heating plate heat the bearings to approximately 125°C (250°F) and install the bearings and spacer onto the shafts



Note some models may have two bearing spacers

Fig 23

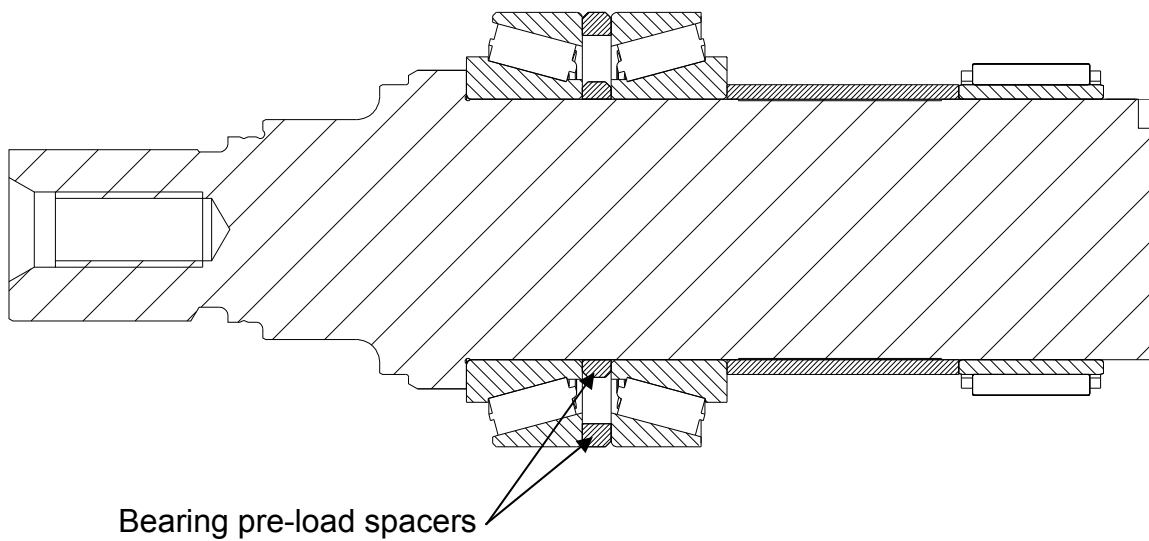

4.2.2 Gearbox.

Fig 24

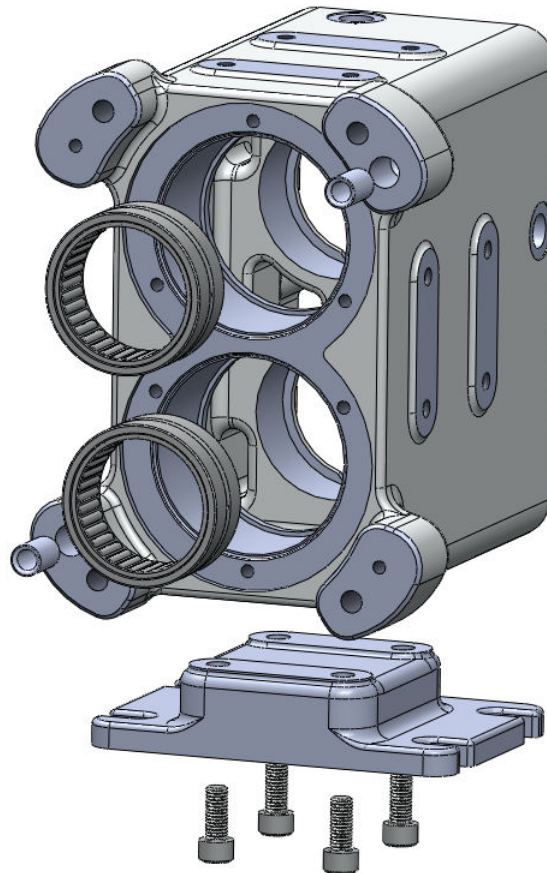

- Install the foot and secure with the screws.

The foot screws need to be retained using a thread locking compound adhesive, loctite 270 or similar.

- Press in the rear outer shells of the needle roller bearings.
- Press in the dowel bushes.

The dowel bushes need to be retained using a retaining compound adhesive, loctite 638 or similar.

4.2.3 Shaft Installation.

Fig 25

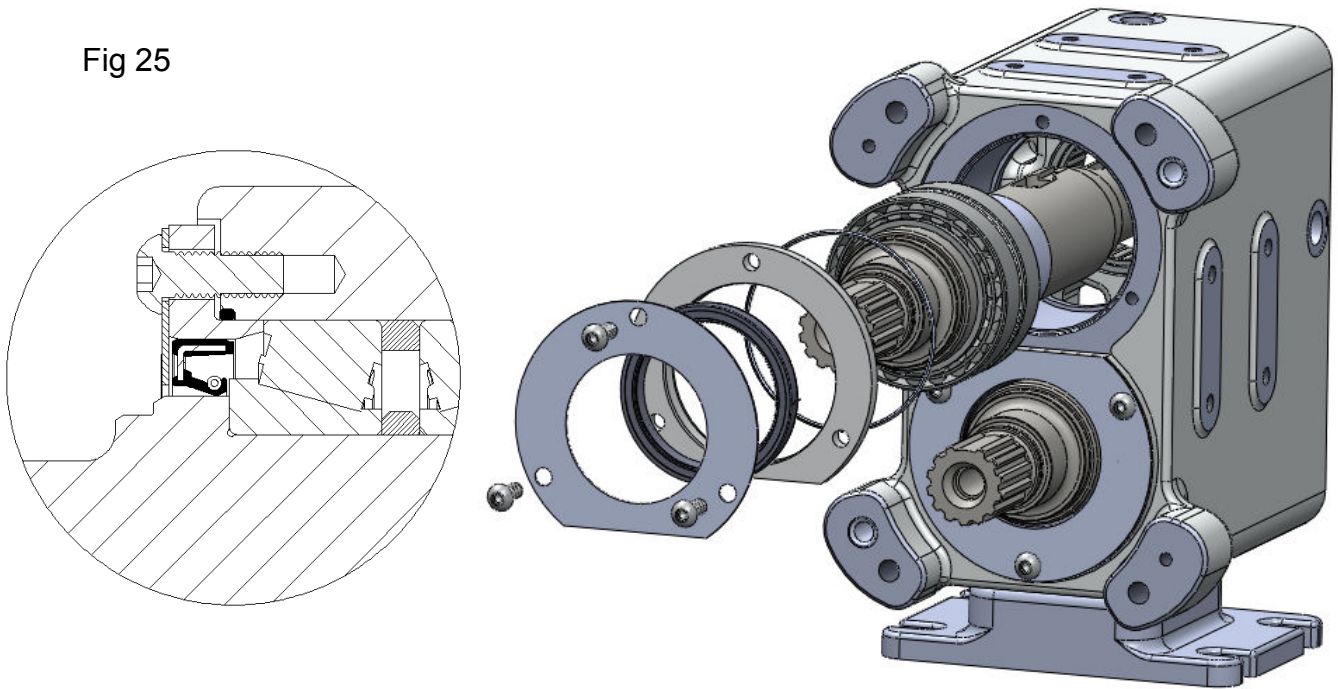

- Install the shaft assemblies.



When installing the shafts make sure they are installed square to the gearbox and that none of the rollers on the needle roller bearing get obstructed.

- Install the lip-seals into the bearing retainer plate.
- Install the o-ring, bearing retainer plate and optional counter face gamma seal.
- Install the screws and torque them up.

See section 6.2 for torque settings.

4.2.4 Timing Marks and Drive Gear Identification.

Fig 26

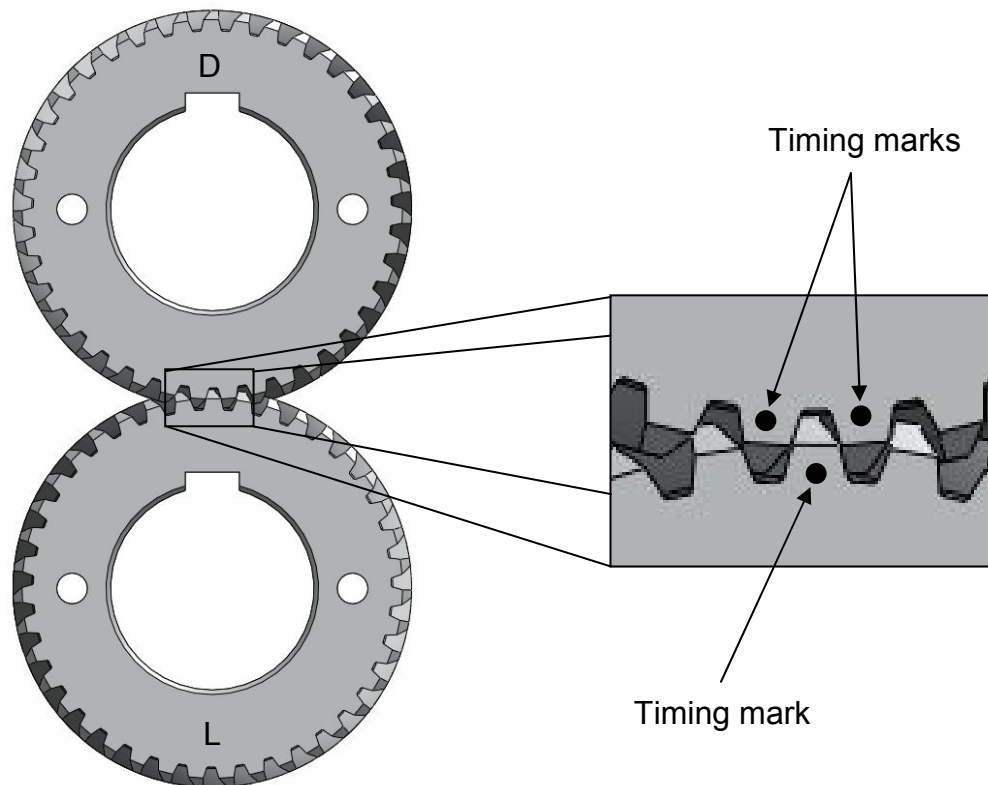

- Before installing the gears into the gearbox timing marks need to be added. Place the gears on a flat surface and align the keyways. When the gears are lined up use a centre punch and lightly add the timing marks shown above.
- The drive gear must be installed onto the drive shaft. The drive gear can be identified by looking at the direction of the helix angle, if the helix angle is slanting to the right then it's the drive gear see below.

Fig 27

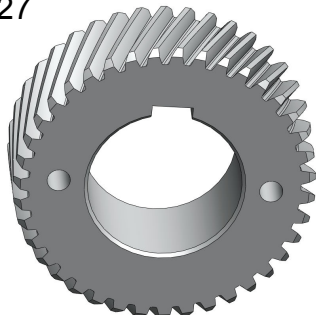
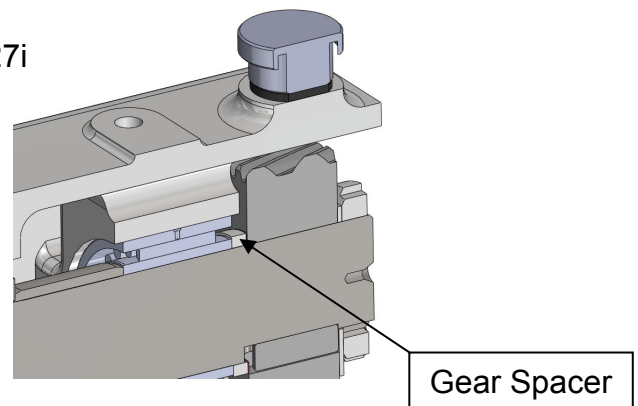

Fig 27i



- When installing the gears note the gear spacer and the keys must be installed first – otherwise the gear will fowl on the gearbox and the timing will move.

4.2.5 Timing.

Fig 30

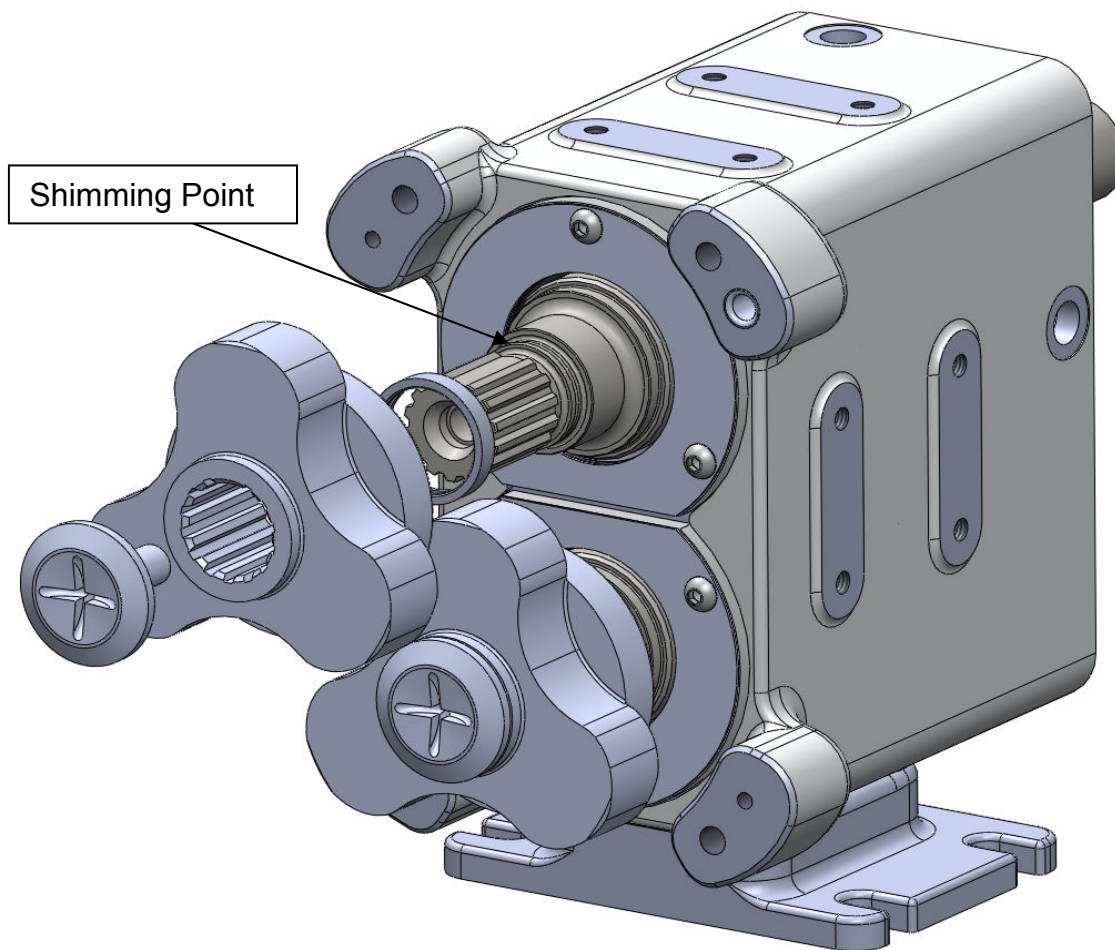

- Install a nominal amount of shim then the front setting rings, rotors and secure using the rotor retainers. Fasten the retainers to the correct torque.

See section 6.2 for torque settings.

- When checking the mesh clearances make sure that the rotor is turned to remove backlash see below.

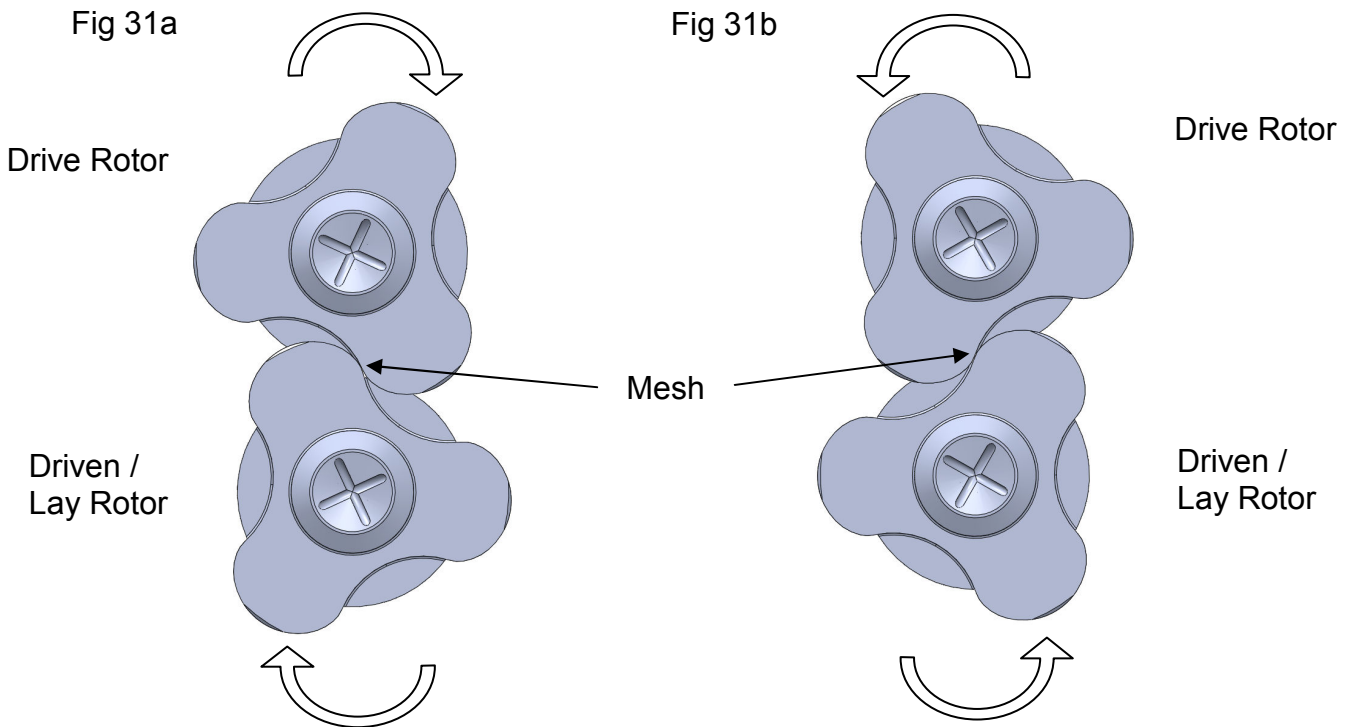

- Check the mesh clearance in all positions and note the minimum mesh clearance, see section 8.1 for clearance charts.
- In Fig 31a to increase the mesh clearance in the position shown you will need to add shim to the lay shaft. Repeat this procedure until the correct rotor mesh clearance is achieved

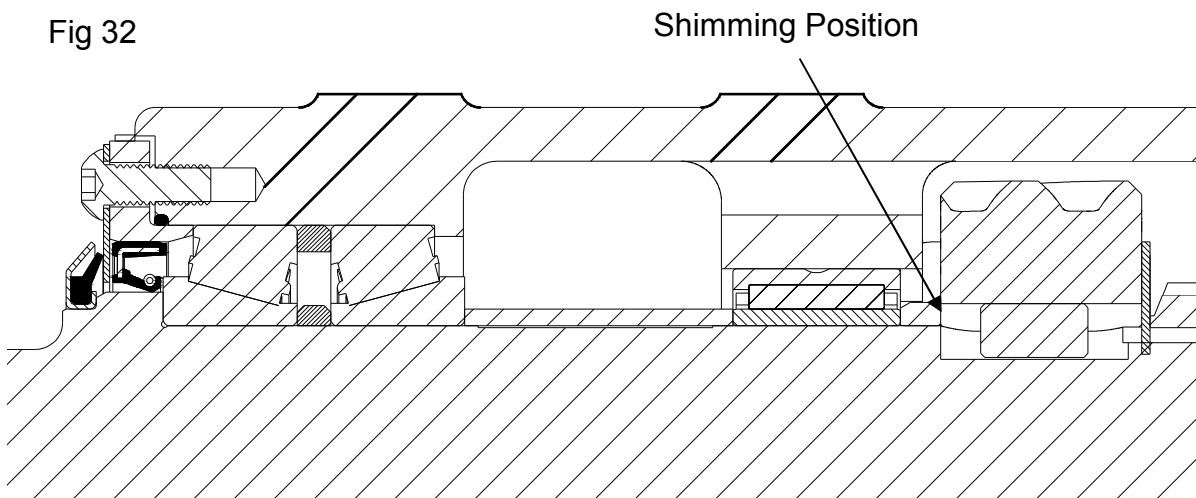

- Install timing shims between the gear and the gear spacer - see above picture
Note:- To do this you will need to remove the rotors, gear and gear key.

4.2.7 Gearbox / Rotorcase Assembly.

Fig 33

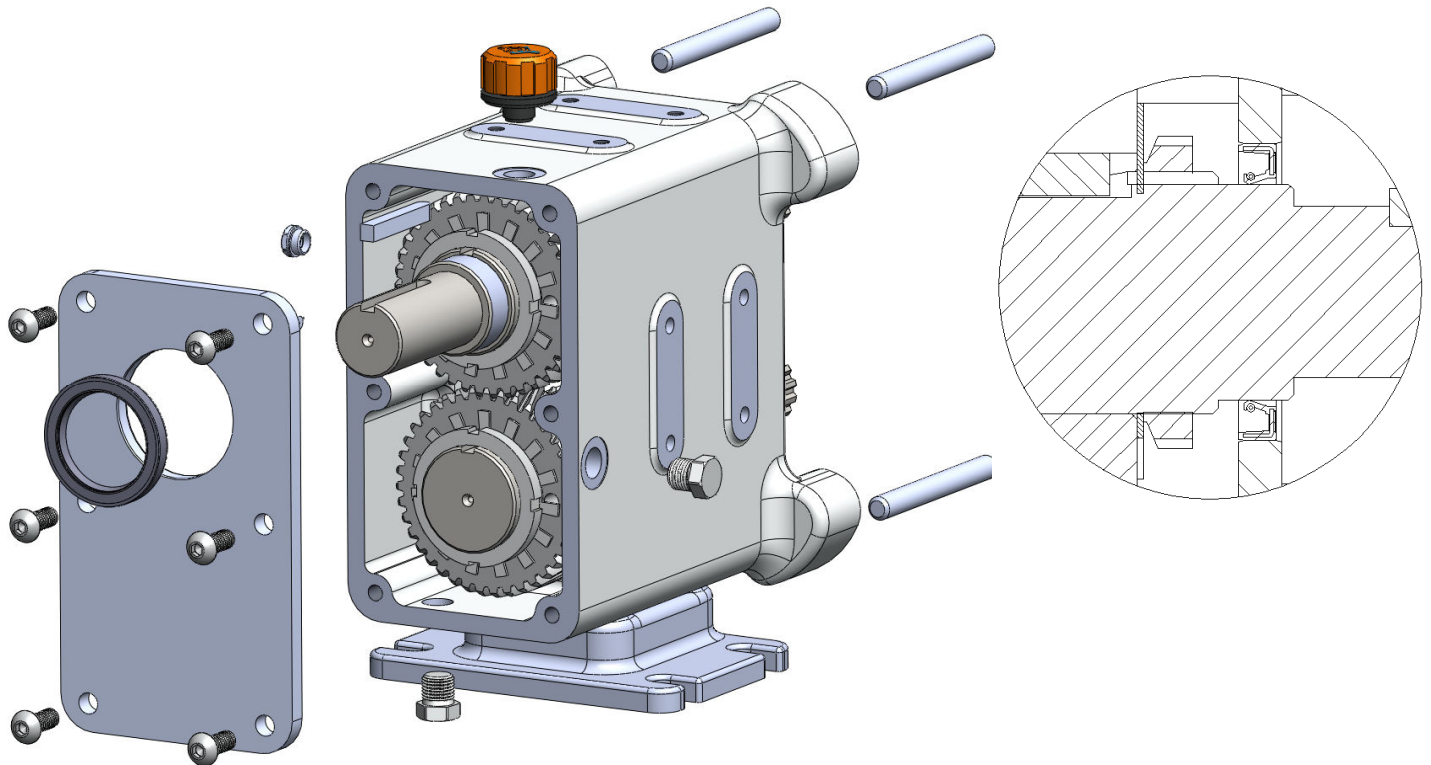

- Once the correct timing is achieved, lock the tab washers onto the gears.
- Install the oil filler plug, oil sight glass and the oil drain plugs (if the pump is to be oil filled) If the pump is grease filled use the drain plugs in all locations.
- Install the lipseal into the gearbox plate.
- Seal the gearbox plate using flange sealant, Dow Corning 732 or similar and secure using the screws. See section 6.2 for torque settings.
- Install the drive key.
- Install the rotorcase studs.

The rotorcase studs need to be retained using a thread locking compound adhesive, Loctite 270 or similar.



Note when install the cover take care not do damage the lipseal on the keyway.

- Install the anti-rotation washers and secure them with the button head screws, see section 6.2 for torque settings.
- Install the dowels.

The dowel bushes need to be retained using a retaining compound adhesive, loctite 638 or similar.

Fig 34

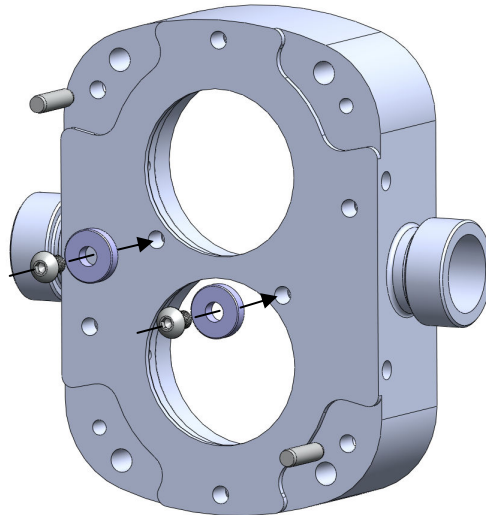

- Install the guard and rotorcase and secure using the retaining screws

Fig 35

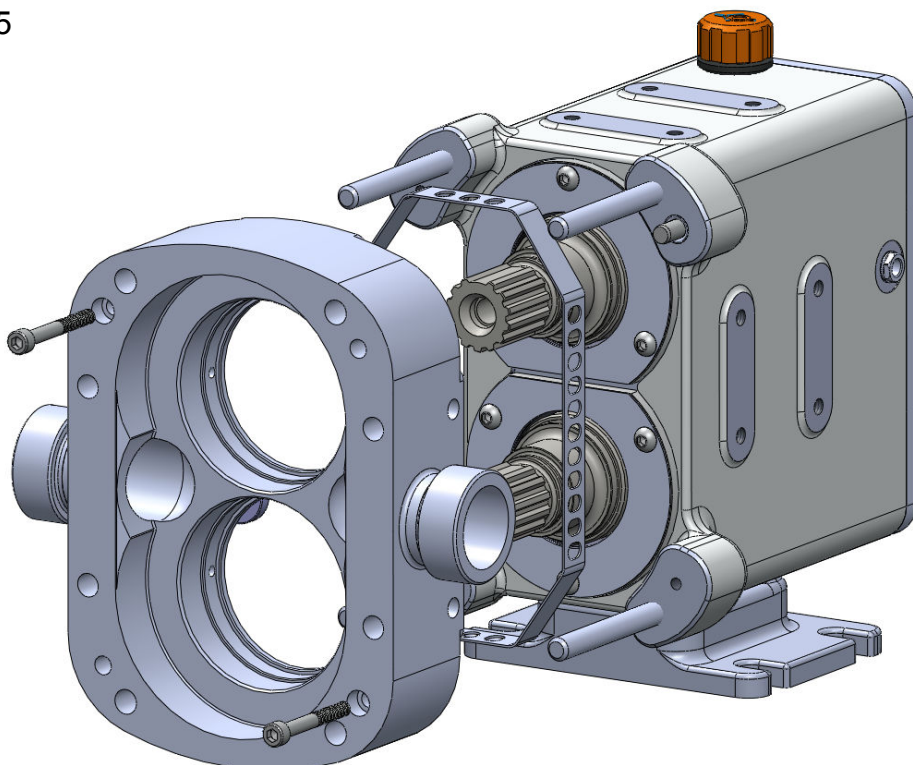

4.2.8 Front Clearance.

Fig 36

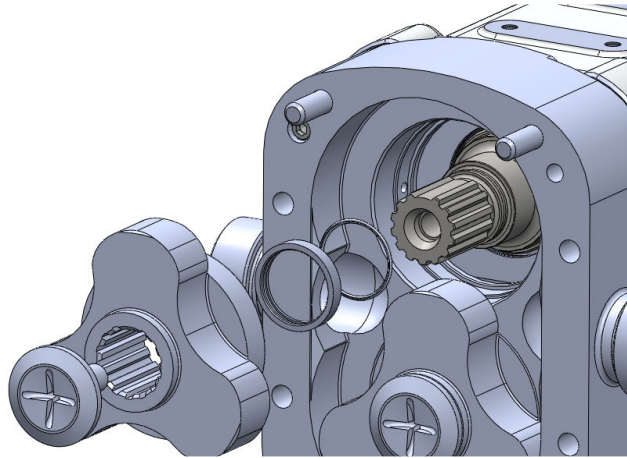

- Install the shims, front setting ring, rotor, rotor retainer and tighten them up, see section 6.2 for torque settings.

Fig 37

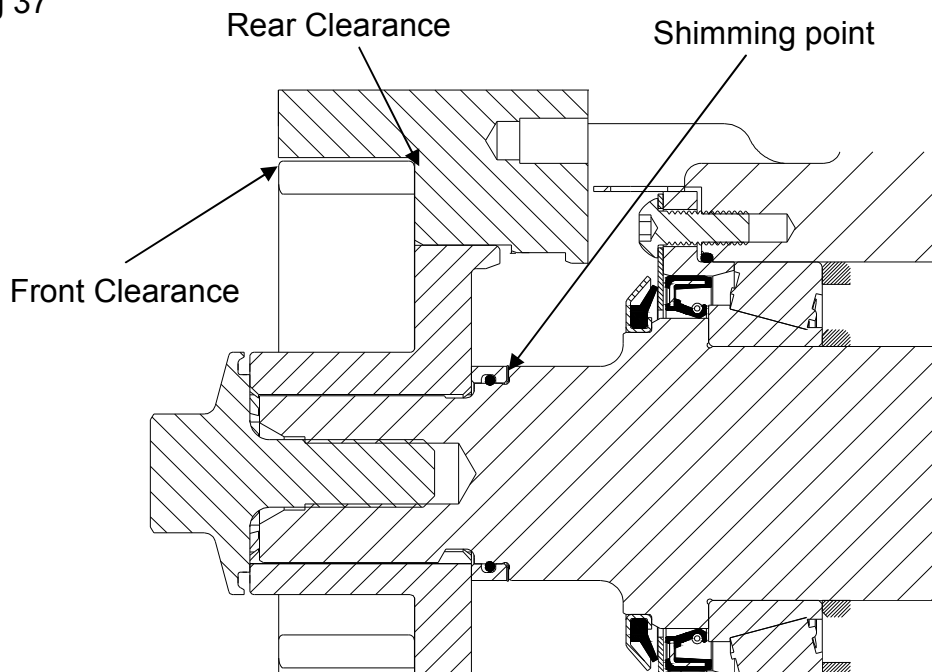

- Measure the front clearance and rear clearance and use the clearance chart section 6.1 to see how much shim you need to add / remove from the shimming point.
- After the front clearances have been set install the o-ring into the setting ring.



When checking the front and rear clearances secure the rotorcase in place using washers and nuts on the studs protruding from the gearbox.

After the front clearance has been set check the radial clearances See section 8.1 for clearance settings.

4.2.9 Final Assembly Size 2,3 and 4.

Fig 38

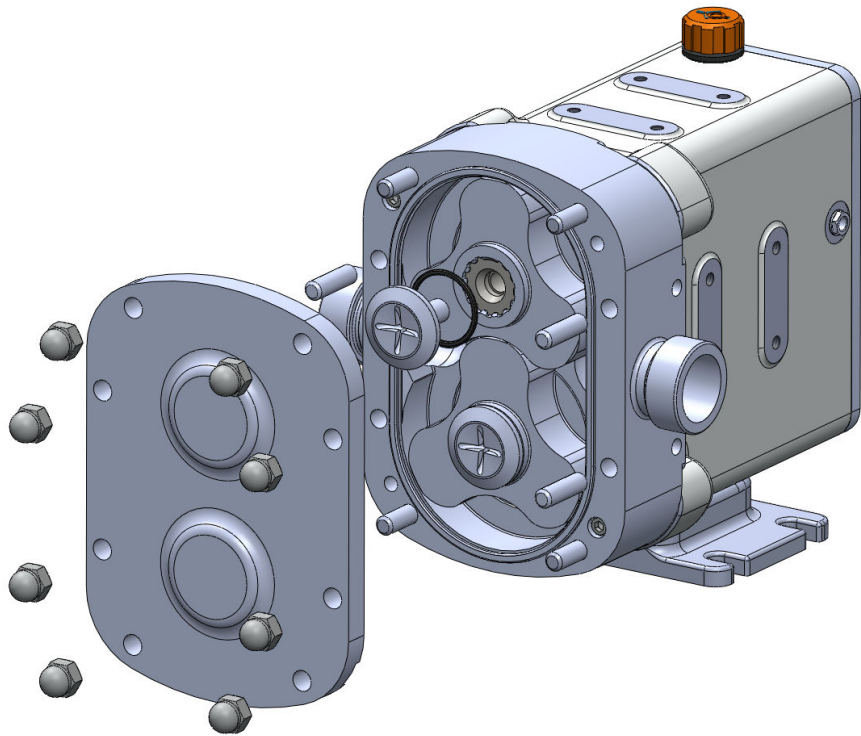

- Install pump seals before final assembly see section 5
- Install the rotor retainer o-ring, rotor retainer and set the torque.
- Install the studs into the rotorcase.

The rotorcase studs need to be retained using a thread locking compound adhesive, loctite 270 or similar.

- Install the front cover o-ring, front cover and secure with the dome nuts.

4.2.10 Final assembly Size 5.

Fig 38i

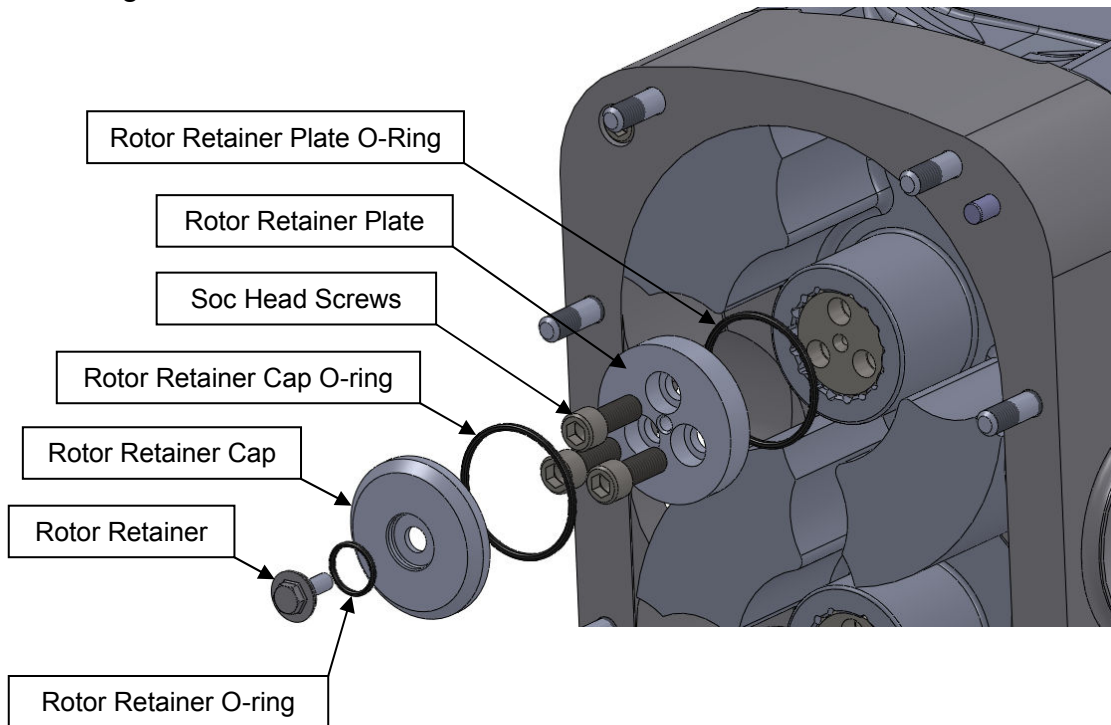

- Install pump seals before final assembly see section 5
- Install the rotor retainer plate o-ring, rotor retainer plate and the three socket head cap screws - See section 6.2 for torque settings.
- Install the rotor retainer cap o-ring and the rotor retainer cap. Secure in place using the rotor retainer o-ring and rotor retainer – See section 6.2 for torque settings.
- Install the studs into the rotorcase.

The rotorcase studs need to be retained using a thread locking compound adhesive, loctite 270 or similar.

- Install the front cover o-ring, front cover and secure with the dome nuts.

5.0 Seal Section.

5.1 Single Seal.

Fig 39

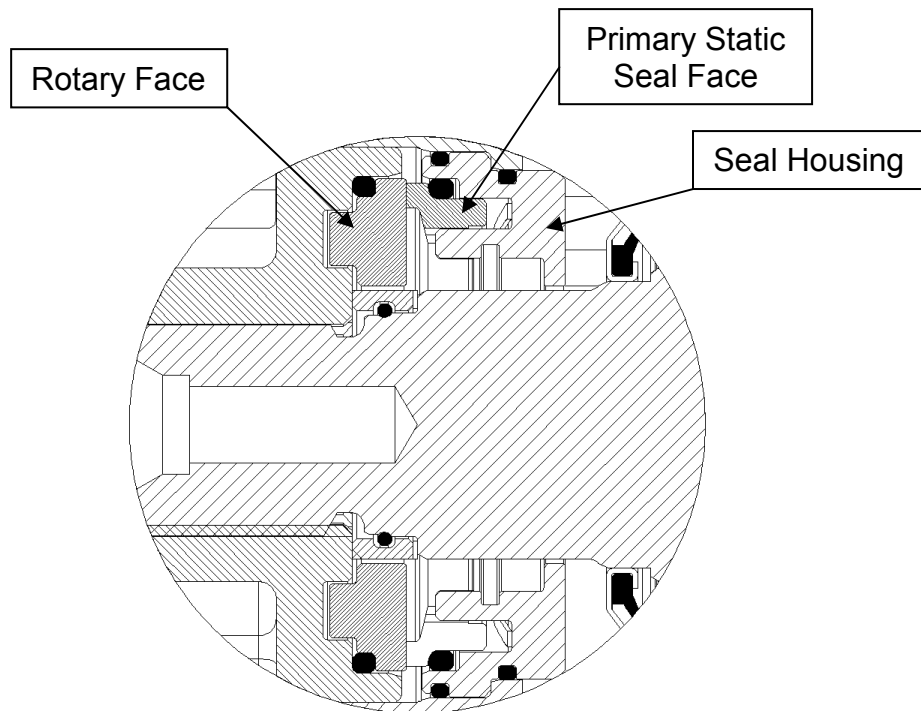
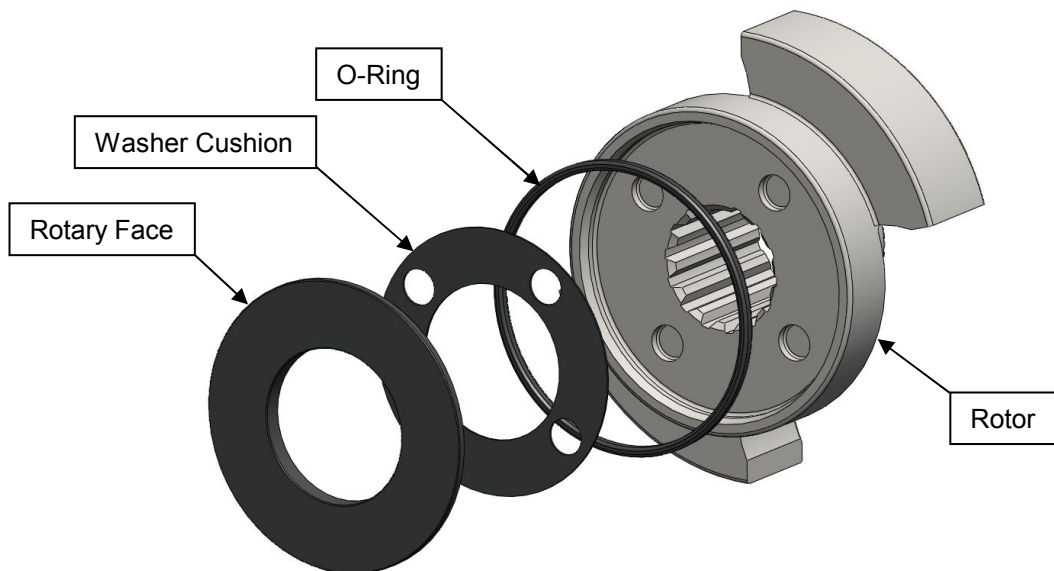
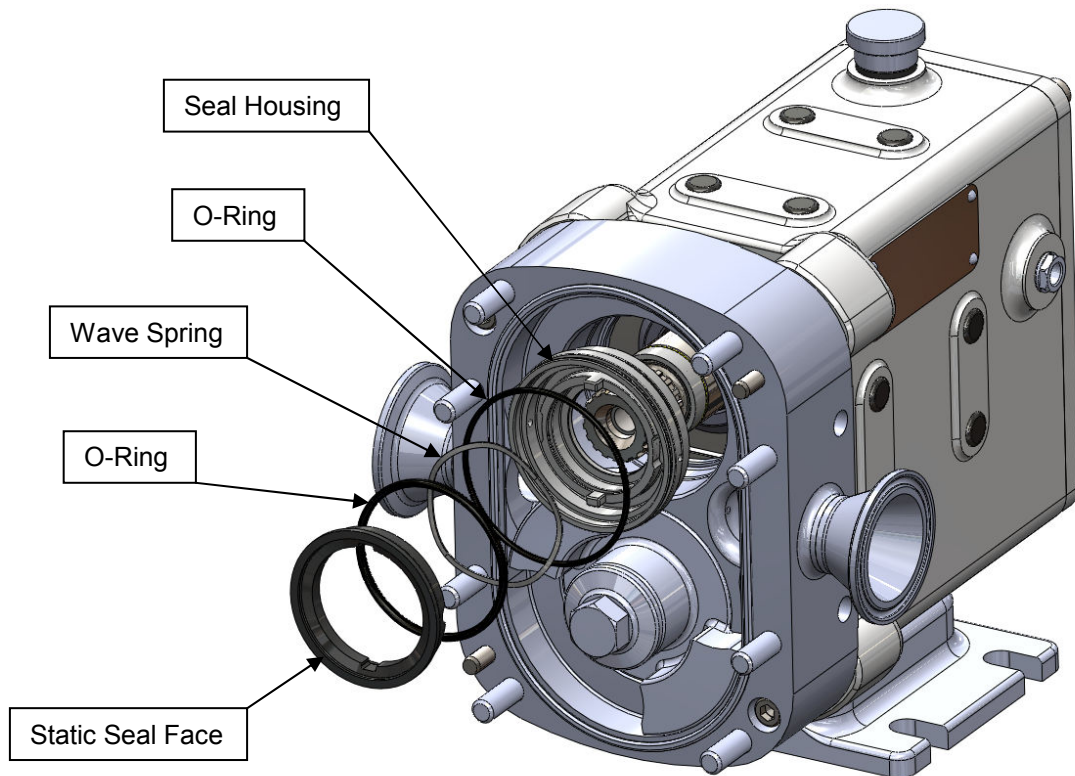

Fig 40



- Install the o-ring into the rotor.
- Install the washer cushion onto the rotary face where applicable, making sure the holes in the washer cushion match the lugs on the rotary face.
- Install the rotary face into the rotor making sure the lugs line up with the anti-rotation holes in the rotor.

Fig 41



- Install the o-ring into the seal housing.
- Install the seal housing into the rotorcase.



When installing the seal housing into the rotorcase the anti-rotation cut out must line up with anti-rotation washer on the rear of the rotorcase. See below

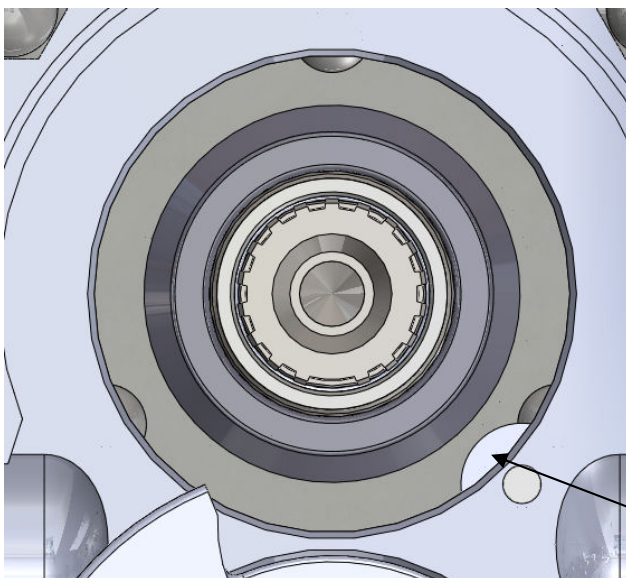

- Install the wave spring into the seal housing.
- Install the o-ring onto the static seal face.
- Install the static seal face into the seal housing.

Anti-Rotation Washer

5.2 Double Seal – Flushed.

Fig 42

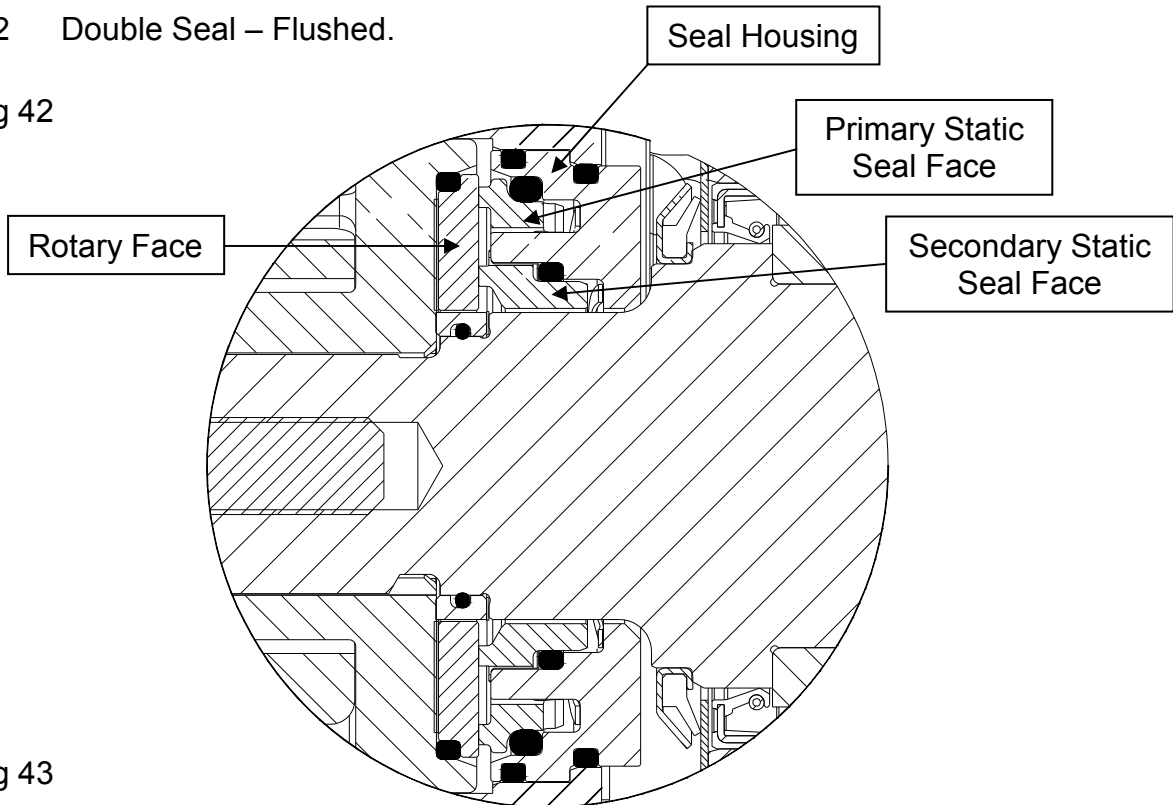
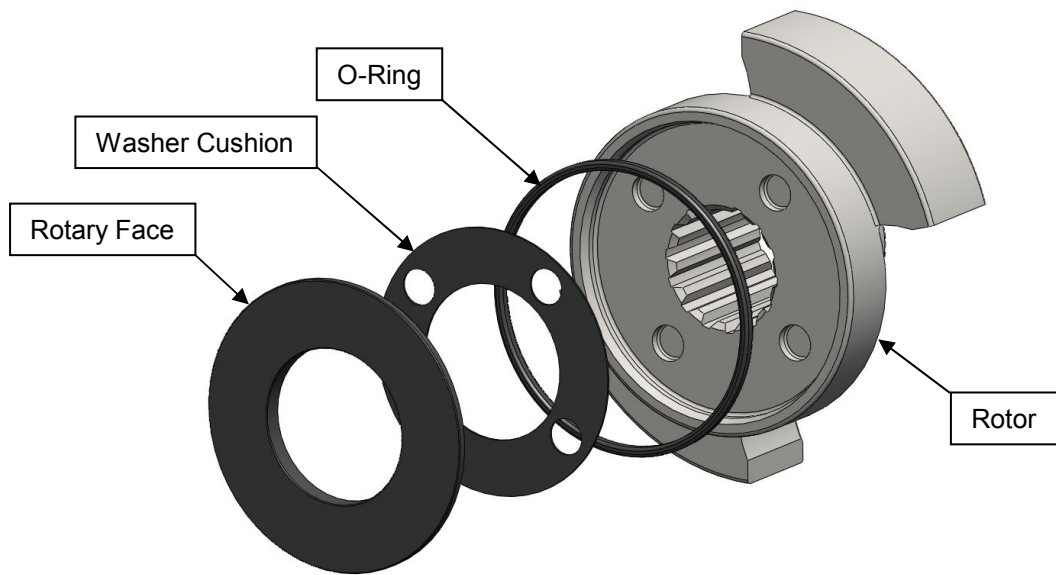

Fig 43



- Install the o-ring into the rotor.
- Install the washer cushion onto the rotary face where applicable, making sure the holes in the washer cushion match the lugs on the rotary face.
- Install the rotary face into the rotor making sure the lugs line up with the anti-rotation holes in the rotor.

Note on the Size 5 there is an extra o-ring that fits on the Internal Diameter of the rotary face

Fig 44

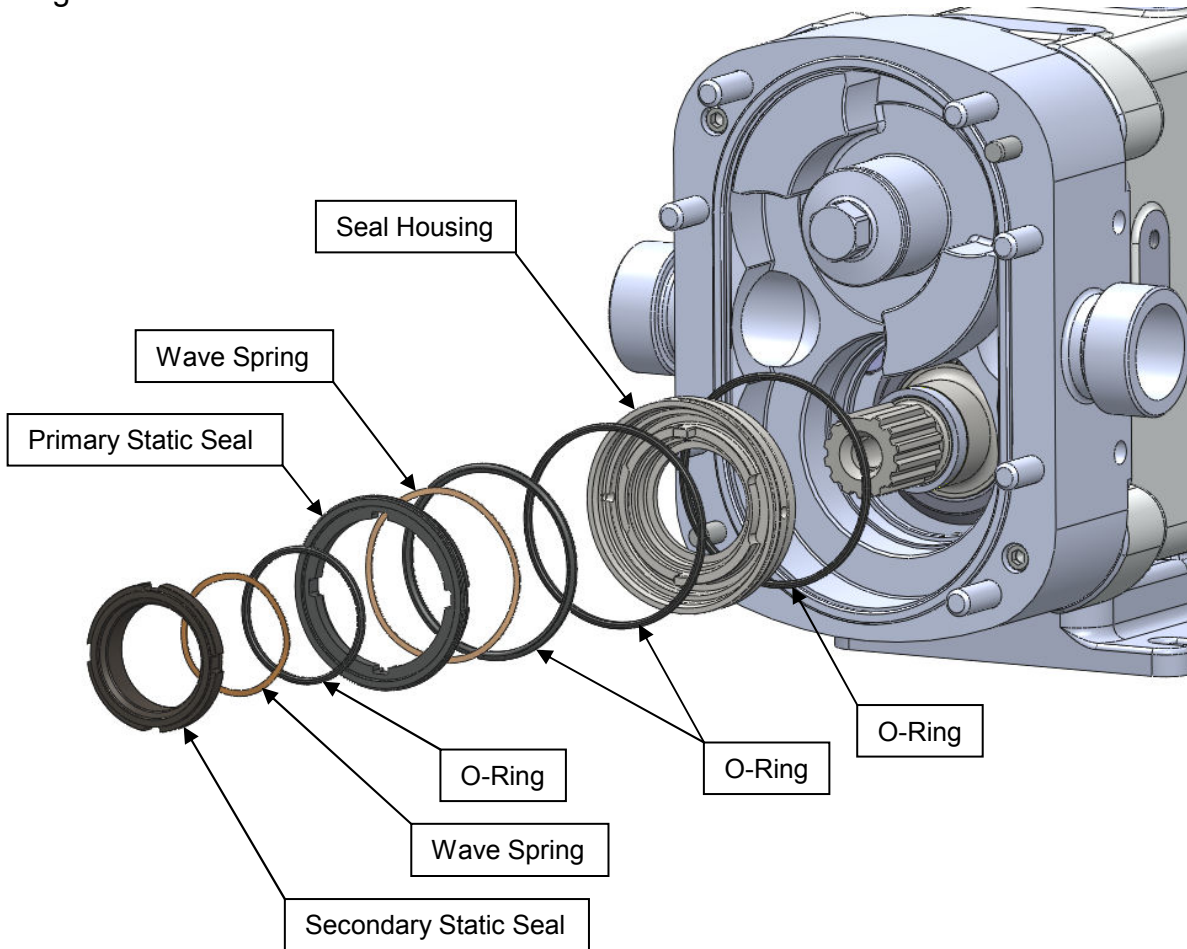

- Install the 2 seal housing o-rings into the seal housing.
- Install the seal housing into the rotorcase .



When installing the seal housing into the rotorcase the anti-rotation cut out must line up with anti-rotation washer on the rear of the rotorcase. See below

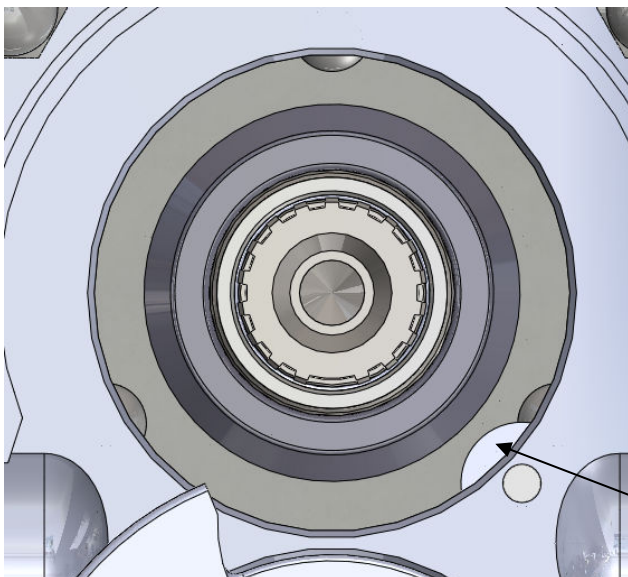

- Install the wave springs into the seal housing.
- Install the o-rings onto the static seals.
- Install the static seals into the seal housing.

Anti-Rotation Washer

5.3 Single O-Ring Seal.

Fig 45

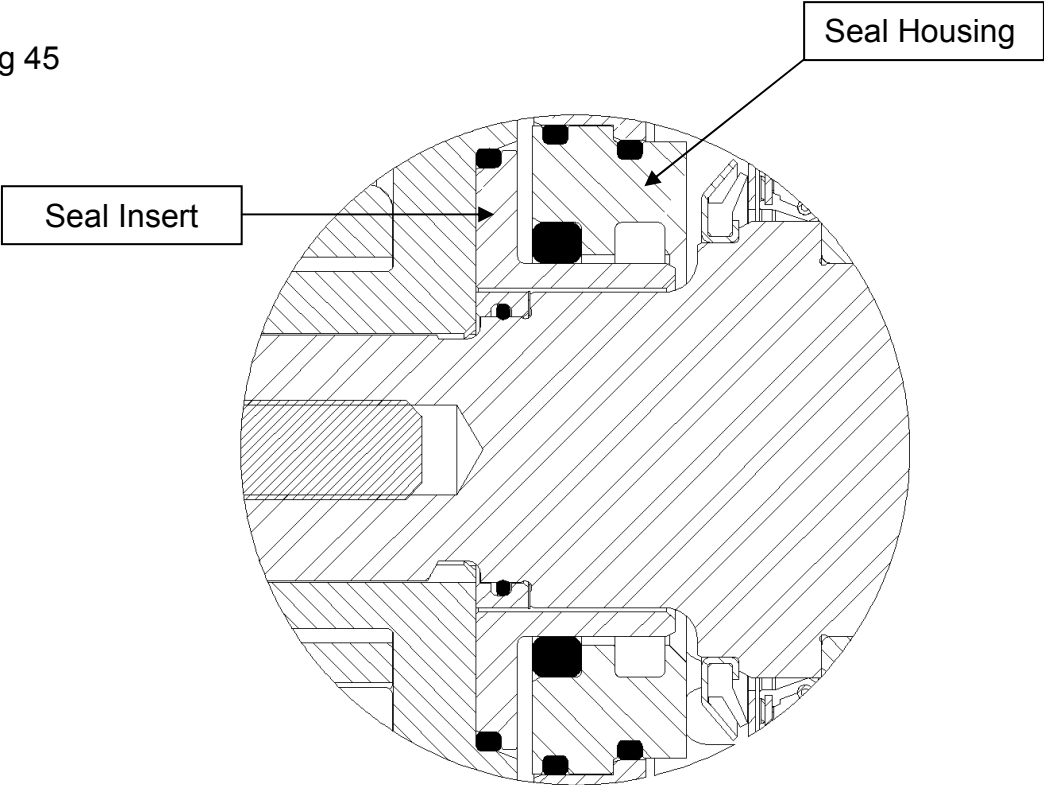
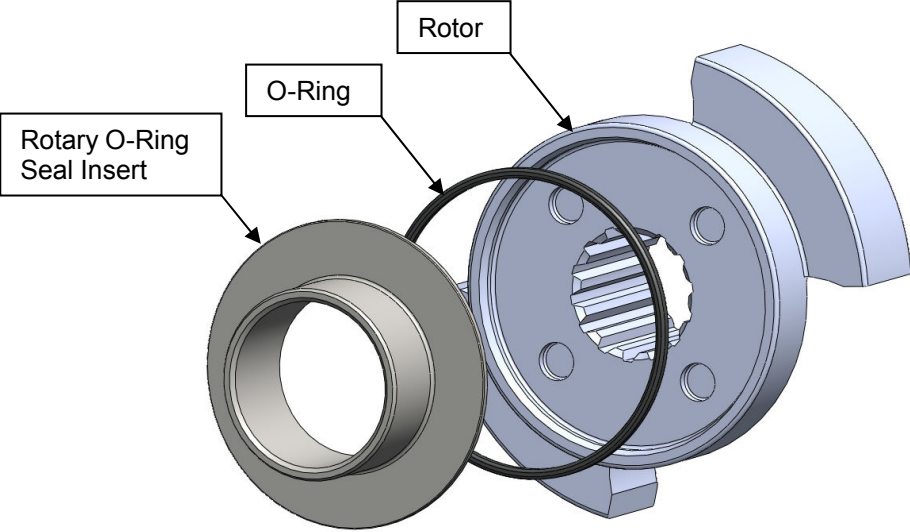
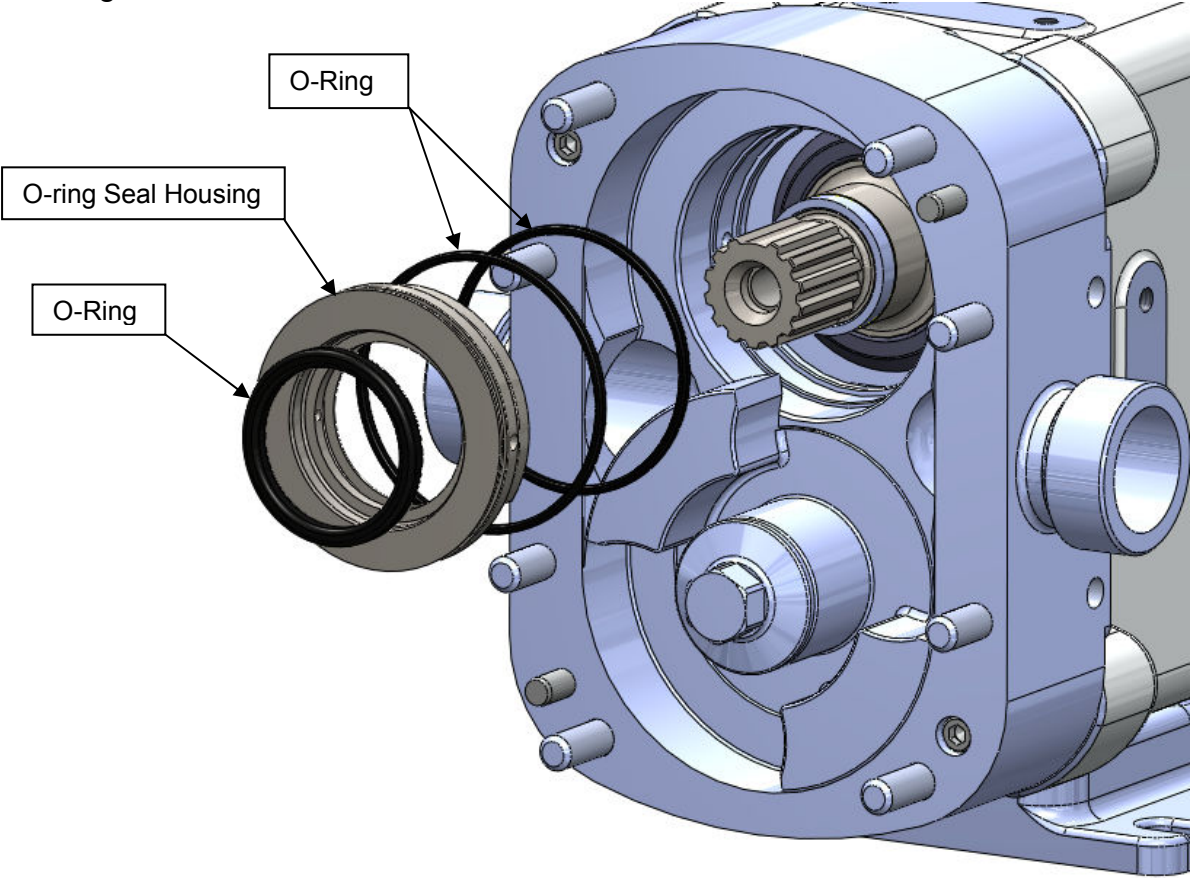

Fig 46



- Install the o-ring onto the rotary o-ring seal insert.
- Install the rotary o-ring seal insert into the rotor.

Fig 47



- Install the o-rings into the housing.
- Install the housing into the rotorcase.



When installing the seal housing into the rotorcase the anti-rotation cut out must line up with anti-rotation washer on the rear of the rotorcase.

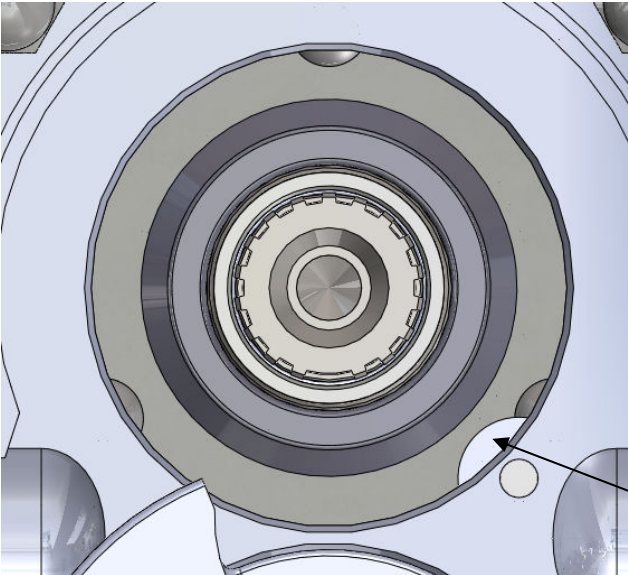

Anti-Rotation Washer

5.4 Double O-Ring Seal – Flushed.

Fig 48

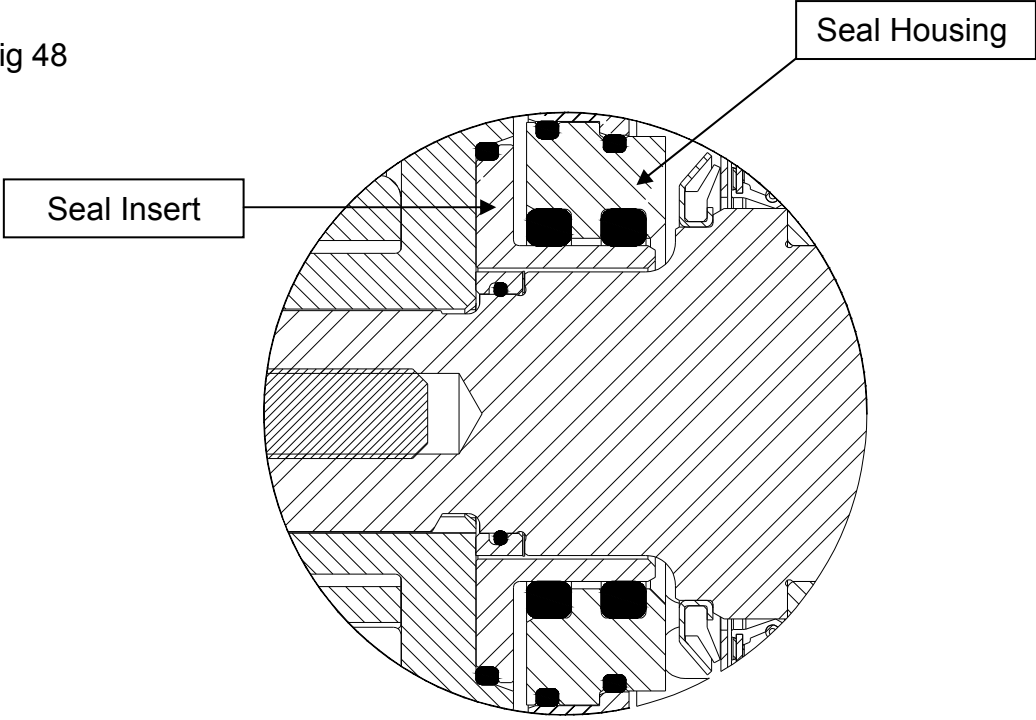
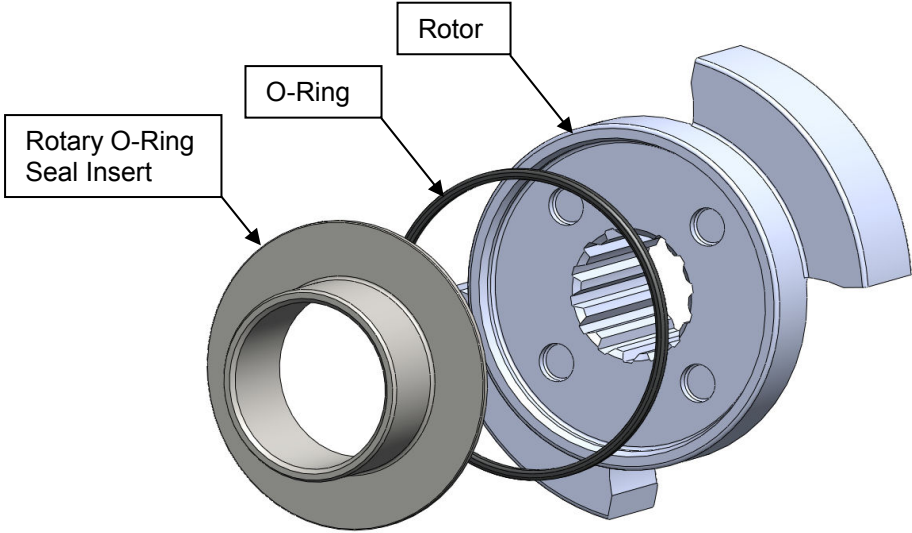
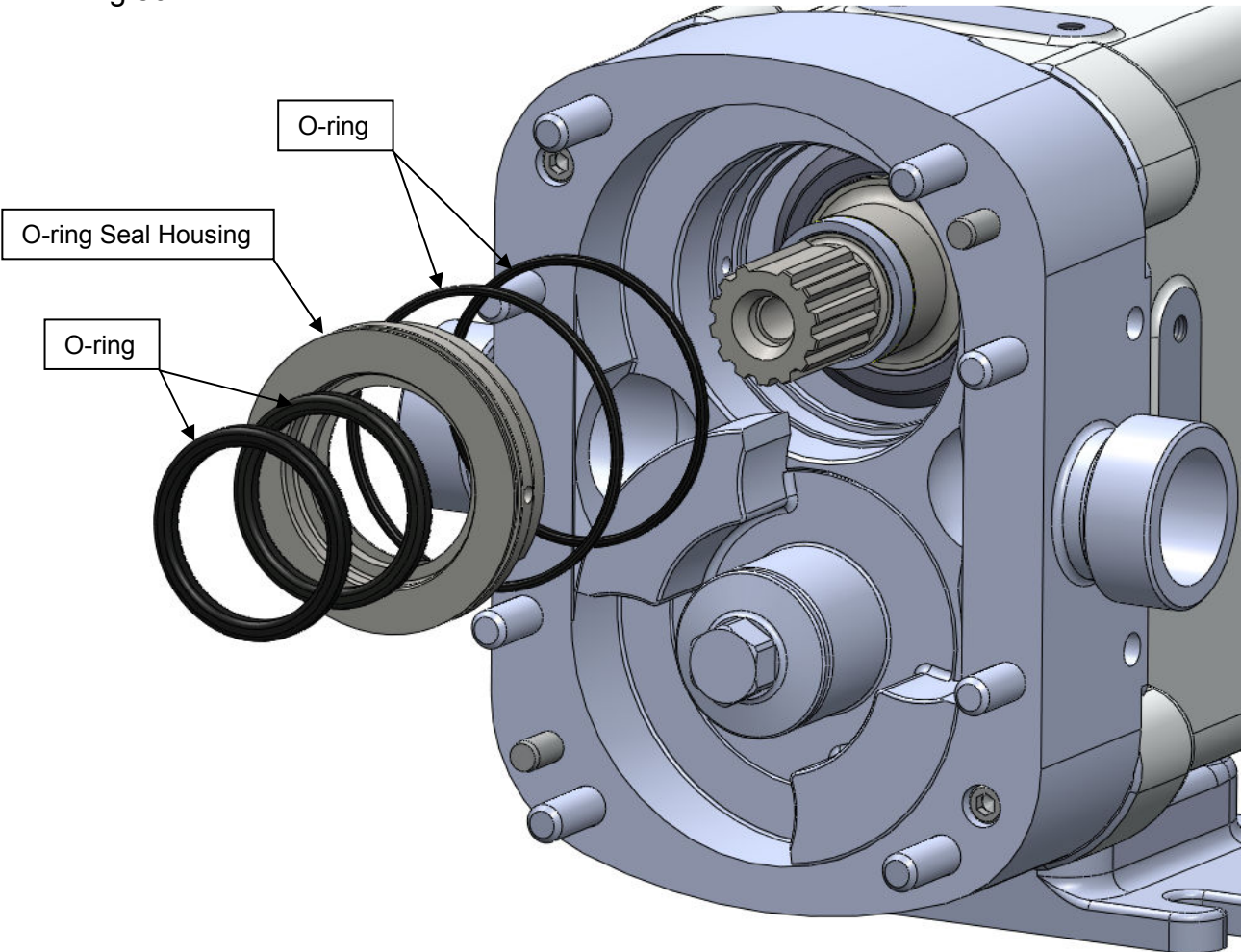

Fig 49



- Install the o-ring onto the rotary o-ring seal insert.
- Install the rotary o-ring seal insert into the rotor.

Fig 50



- Install the o-rings into the housing.
- Install the housing into the rotorcase.



When installing the seal housing into the rotorcase the anti-rotation cut out must line up with anti-rotation washer on the rear of the rotorcase.

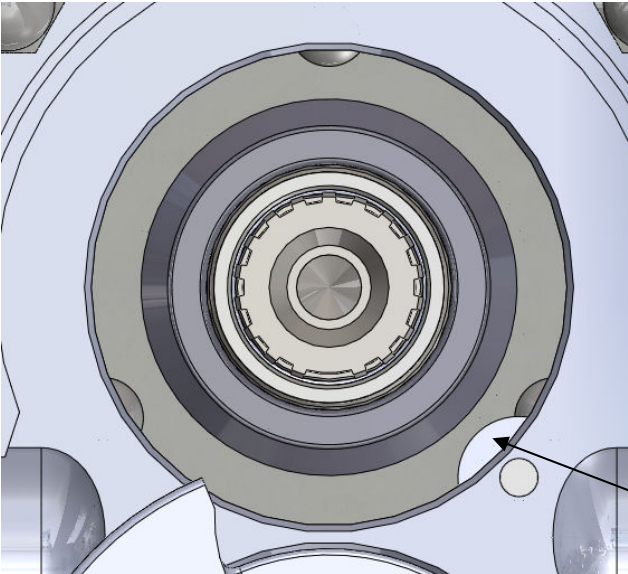

Anti-Rotation Washer

5.5 Flushed Product Seals Auxiliary Services.

i) Terminology "Flush"

To provide a liquid barrier that is induced to flow through the seal area by an external means

ii) Flush Media

The media used for flushing a seal area must be fully compatible with the pumped media, and the relevant materials of construction of the pump. Special consideration must be given to the temperature limitations of the media to ensure that no hazards are created, e.g. risk of fire or explosion.

WARNING

5.6 Double Mechanical Seal.

This seal arrangement requires a supply of media to be circulated between the inboard and outboard mechanical seals.

$$Q = \frac{(0.6 \times p + 0.25) \times n \times d^3 \times T}{c_p \times \rho \times 2.5 \times 10^9}$$

Q = Flow rate	[l/hr]
p = Applied buffer / barrier pressure	[bar]
n = Shaft speed	[rpm]
d = Shaft diameter	[mm]
T = Temperature of processed media	[°C]
ρ = Specific gravity of buffer / barrier fluid	[kg/dm ³]
c _p = Specific heat capacity for buffer / barrier fluid	[kJ/(kg x K)]

Typical values for some common barrier fluids:

Media	Density [kg/dm ³]	Specific Heat [kJ/(kg x K)]
Water	1.0	4.2
Olive Oil	0.9	1.6
Mineral Oil	0.9	1.7
Acetone	0.8	2.2

The flush media must be supplied at a minimum flow rate of 0.5 Litres/ Minute per seal, this can be worked out by the following equation where "Q" is the flow rate.

The flush pressure must be a minimum of 1 Bar (15 psi) greater than the maximum discharge pressure created by, or the maximum suction pressure applied to, the pump, whichever is the greater.

WARNING

Note: The liquid supply connections to flushed seals are made using the threaded ports on the sides of the rotorcase. The pipe work should be arranged to provide an independent flush to each seal.

5.7 Operating parameters

Pressure / Speed Limits

Pressure and speed are two of the most important factors for frictional heat generation in a mechanical seal and the seal face material properties set limits to these parameters. Depending on the properties of the processed product, the mechanical seal design and the seal face materials tribological, physical and thermal properties, the limits specified below can differ.

SEAL FACE COMBINATION

Size 2

Single seal:	Max pressure (at speed)	Max speed (at pres.)
Carbon v. Silicon Carbide	21 bar (1000 rpm)	1000 rpm (21 bar)
Silicon Carbide v. Silicon Carbide	21 bar (1000 rpm)	1000 rpm (21 bar)
Double outboard seal:	Max pressure (at speed)	Max speed (at pres.)
Carbon v. Silicon Carbide	22 bar (1000 rpm)	1000 rpm (22 bar)

Size 3

Single seal:	Max pressure (at speed)	Max speed (at pres.)
Carbon v. Silicon Carbide	21 bar (1000 rpm)	1000 rpm (21 bar)
Silicon Carbide v. Silicon Carbide	21 bar (1000 rpm)	1000 rpm (21 bar)
Double outboard seal:	Max pressure (at speed)	Max speed (at pres.)
Carbon v. Silicon Carbide	22 bar (1000 rpm)	1000 rpm (22 bar)

Size 4

Single seal:	Max pressure (at speed)	Max speed (at pres.)
Carbon v. Silicon Carbide	31 bar (800 rpm)	800 rpm (31 bar)
Silicon Carbide v. Silicon Carbide	31 bar (675 rpm)	800 rpm (24 bar)
Double outboard seal:	Max pressure (at speed)	Max speed (at pres.)
Carbon v. Silicon Carbide	32 bar (800 rpm)	800 rpm (32 bar)

Size 5

Single seal:	Max pressure (at speed)	Max speed (at pres.)
Carbon v. Silicon Carbide	31 bar (600 rpm)	600 rpm (31 bar)
Silicon Carbide v. Silicon Carbide	31 bar (375 rpm)	600 rpm (17 bar)
Double outboard seal:	Max pressure (at speed)	Max speed (at pres.)
Carbon v. Silicon Carbide	23 bar (600 rpm)	600 rpm (23 bar)

6.0 Specifications.

6.1 Clearance Chart.

RLP Rotors

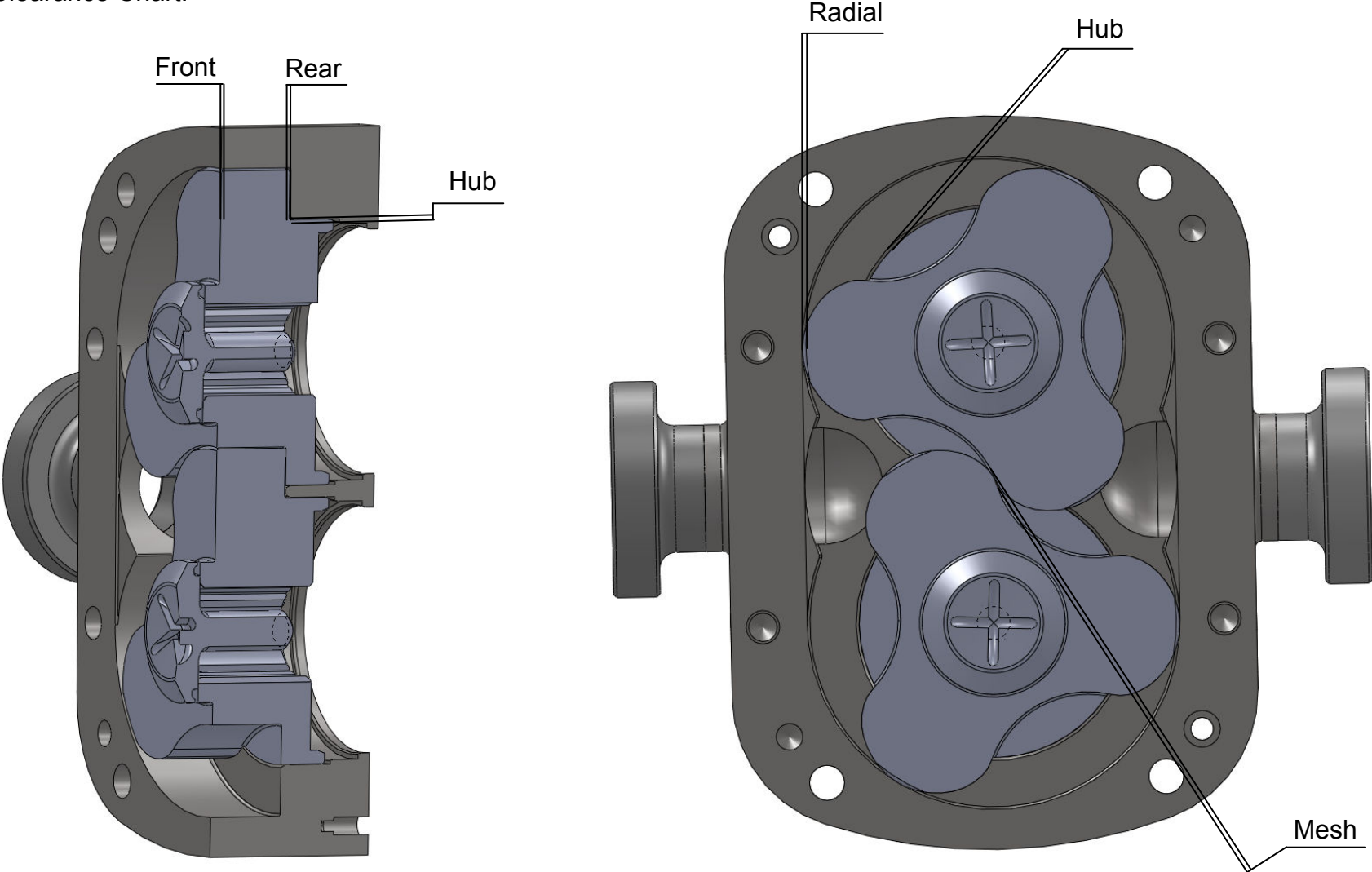

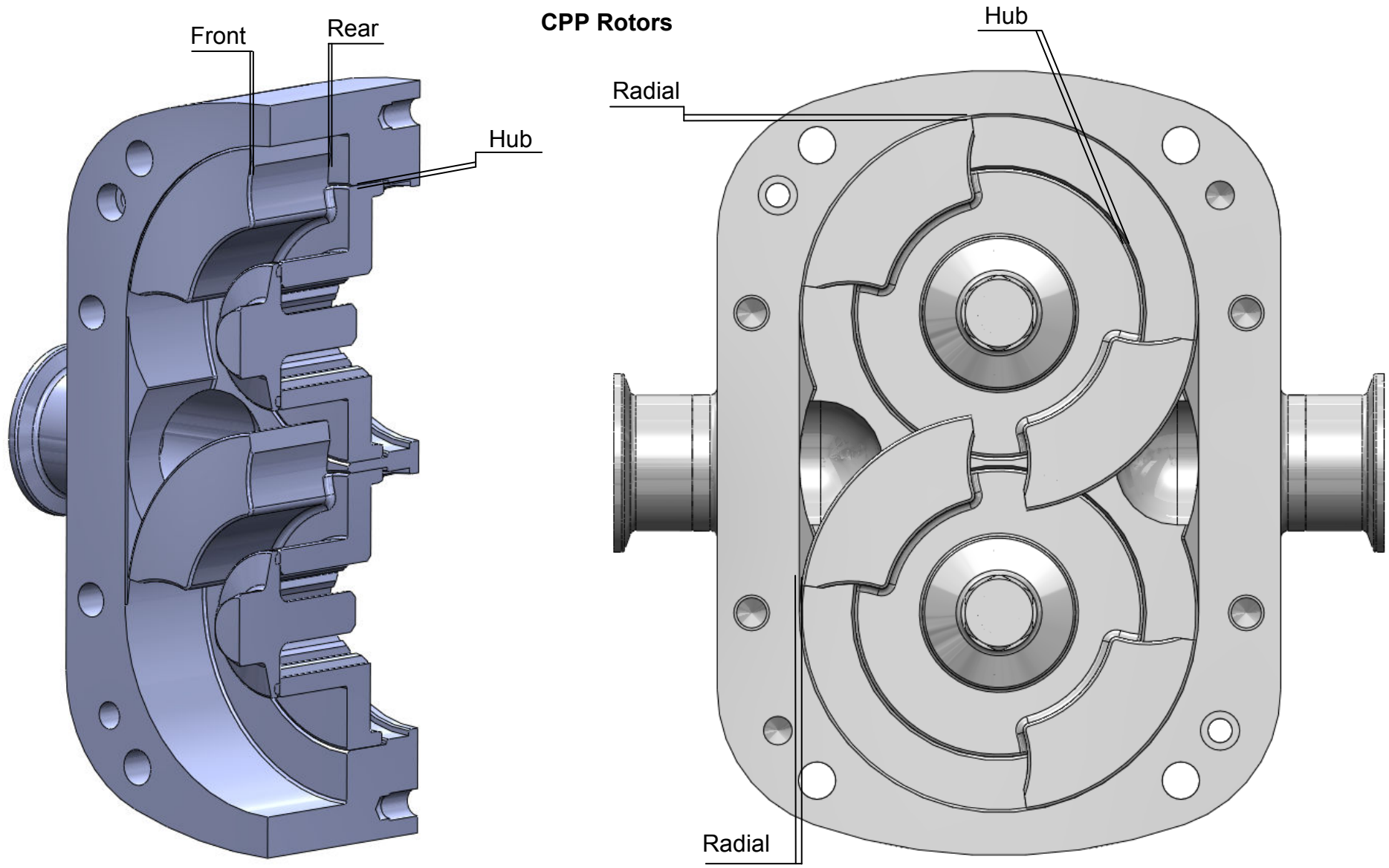

Revolution CPP - 808 ALLOY

Metric (mm)

	Model	Rotor Class	Temp Max (°C)	Front		Rear	Radial		Hub	
				Min	Max	Min	Min	Max	Min	Max
				SIZE 2	R0150 R0180	STANDARD	93	0.07	0.10	0.04
FF	105	0.145	0.175	0.04		0.04	0.09	0.04	0.08	
HOT	150	0.16	0.21	0.04		0.09	0.13	0.11	0.17	
		CHOCOLATE (HIGH VISCOSITY)	REFER TO FACTORY	0.17	0.22	0.11	0.13	0.17	0.24	0.31
SIZE 3	R0200 R0300 R0400	STANDARD	93	0.07	0.10	0.05	0.05	0.10	0.04	0.08
FF		105	0.15	0.18	0.05	0.05	0.10	0.04	0.08	
HOT		150	0.16	0.21	0.06	0.09	0.13	0.10	0.16	
CHOCOLATE (HIGH VISCOSITY)		REFER TO FACTORY	0.18	0.23	0.12	0.11	0.15	0.21	0.27	
SIZE 4	R0450X R0600P	STANDARD	93	0.145	0.175	0.07	0.1	0.16	0.08	0.13
FF		105	0.245	0.275	0.07	0.1	0.16	0.08	0.13	
HOT		150	0.25	0.30	0.12	0.18	0.23	0.22	0.29	
CHOCOLATE (HIGH VISCOSITY)		REFER TO FACTORY	0.27	0.32	0.19	0.20	0.25	0.33	0.40	
	R0800X R1300X	STANDARD	93	0.145	0.175	0.07	0.11	0.16	0.075	0.125
FF		105	0.245	0.275	0.07	0.11	0.16	0.075	0.125	
HOT		150	0.25	0.3	0.12	0.18	0.23	0.22	0.29	
		CHOCOLATE (HIGH VISCOSITY)	REFER TO FACTORY	0.27	0.32	0.19	0.2	0.25	0.33	0.4
SIZE 5	R1800P	STANDARD	93	0.14	0.2	0.12	0.12	0.18	0.09	0.16
FF		105	0.27	0.3	0.115	0.12	0.18	0.09	0.16	
HOT		150	0.27	0.3	0.12	0.29	0.34	0.24	0.32	
CHOCOLATE (HIGH VISCOSITY)		REFER TO FACTORY	0.27	0.3	0.19	0.3	0.36	0.24	0.32	
	R2200P R2600P	STANDARD	93	0.17	0.23	0.12	0.14	0.21	0.09	0.19
FF		105	0.27	0.3	0.115	0.14	0.21	0.09	0.19	
HOT		150	0.27	0.3	0.12	0.29	0.34	0.24	0.32	
CHOCOLATE (HIGH VISCOSITY)		REFER TO FACTORY	0.27	0.3	0.19	0.3	0.36	0.24	0.32	

Imperial (inch) ÷ 100

	Model	Rotor Class	Temp Max (°F)	Front		Rear	Radial		Hub	
				Min	Max	Min	Min	Max	Min	Max
				SIZE 2	R0150 R0160 R0180	STANDARD	200	0.28	0.39	0.16
FF	221	0.57	0.69	0.16		0.16	0.35	0.16	0.31	
HOT	302	0.63	0.83	0.16		0.35	0.51	0.43	0.67	
CHOCOLATE (HIGH VISCOSITY)	REFER TO FACTORY	0.67	0.87	0.43		0.51	0.67	0.94	1.22	
SIZE 3	R0200 R0300 R0400	STANDARD	200	0.28	0.39	0.20	0.20	0.39	0.16	0.31
FF		221	0.59	0.71	0.20	0.20	0.39	0.16	0.31	
HOT		302	0.63	0.83	0.24	0.35	0.51	0.39	0.63	
CHOCOLATE (HIGH VISCOSITY)		REFER TO FACTORY	0.71	0.91	0.47	0.43	0.59	0.83	1.06	
SIZE 4	R0450X R0600P	STANDARD	200	0.57	0.69	0.28	0.39	0.63	0.30	0.49
FF		221	0.96	1.08	0.28	0.39	0.63	0.30	0.49	
HOT		302	0.98	1.18	0.47	0.71	0.91	0.87	1.14	
CHOCOLATE (HIGH VISCOSITY)		REFER TO FACTORY	1.06	1.26	0.75	0.79	0.98	1.30	1.57	
	R0800X R1300X	STANDARD	200	0.57	0.69	0.28	0.43	0.63	0.30	0.49
FF		221	0.96	1.08	0.28	0.43	0.63	0.30	0.49	
HOT		302	0.98	1.18	0.47	0.71	0.91	0.87	1.14	
		CHOCOLATE (HIGH VISCOSITY)	REFER TO FACTORY	1.06	1.26	0.75	0.79	0.98	1.30	1.57
SIZE 5	R1800P	STANDARD	200	0.55	0.787	0.472	0.472	0.709	0.354	0.63
FF		221	1.06	1.181	0.453	0.472	0.709	0.354	0.63	
HOT		302	1.06	1.181	0.472	1.142	1.339	0.945	1.26	
CHOCOLATE (HIGH VISCOSITY)		REFER TO FACTORY	1.06	1.181	0.748	1.181	1.417	0.945	1.26	
	R2200P R2600P	STANDARD	200	0.67	0.906	0.472	0.551	0.827	0.354	0.748
FF		221	1.06	1.18	0.45	0.55	0.83	0.35	0.75	
HOT		302	1.06	1.18	0.47	1.14	1.34	0.94	1.26	
CHOCOLATE (HIGH VISCOSITY)		REFER TO FACTORY	1.06	1.181	0.748	1.181	1.417	0.945	1.26	



Clearances are set at the time of original build and may move small amounts during operation. They will however, remain within the published limits.

It is recommended that clearances are always checked and corrected (if necessary) during any periodic maintenance of the product.

Revolution RLP STAINLESS STEEL

Metric (mm)

	Model	Temp Class Max (°C)	Front		Rear		Radial		Hub		Mesh
			Min	Max	Min	Max	Min	Max	Min	Max	Nominal
SIZE 2	RO150X	70	0.07	0.09	0.09	0.12	0.09	0.16	0.11	0.17	0.17
		150	0.14	0.17	0.16	0.19	0.16	0.24	0.24	0.31	0.17
	RO160L R0180L	70	0.07	0.10	0.09	0.12	0.09	0.17	0.11	0.17	0.17
		150	0.14	0.17	0.16	0.19	0.16	0.24	0.24	0.31	0.17
SIZE 3	R0200X	70	0.23	0.25	0.15	0.17	0.14	0.21	0.10	0.16	0.17
		150	0.29	0.32	0.21	0.24	0.21	0.29	0.21	0.27	0.17
	R0300X R0400X	70	0.22	0.25	0.14	0.17	0.14	0.21	0.10	0.16	0.17
		150	0.29	0.32	0.21	0.24	0.21	0.29	0.21	0.27	0.17
SIZE 4	R0450X R0800X R1300X	70	0.23	0.25	0.13	0.15	0.18	0.25	0.22	0.29	0.20
		150	0.27	0.29	0.17	0.19	0.29	0.37	0.33	0.40	0.20
	Size 5	R01800X	70	0.12	0.19	0.13	0.23	0.11	0.19	0.17	0.25

Imperial (inch) ÷ 100

	Model	Temp Class Max (°F)	Front		Rear		Radial		Hub		Mesh
			Min	Max	Min	Max	Min	Max	Min	Max	Nominal
SIZE 2	RO150X	158	0.28	0.37	0.35	0.45	0.35	0.64	0.41	0.69	0.67
		302	0.55	0.65	0.63	0.73	0.65	0.94	0.94	1.22	0.67
	RO160L	158	0.28	0.37	0.35	0.45	0.35	0.67	0.41	0.69	0.67
		302	0.55	0.65	0.63	0.73	0.65	0.94	0.94	1.22	0.67
SIZE 3	R0200X	158	0.89	0.98	0.57	0.67	0.55	0.84	0.37	0.65	0.67
		302	1.14	1.24	0.83	0.93	0.81	1.14	0.81	1.08	0.67
	R0300X	158	0.89	0.98	0.57	0.67	0.55	0.84	0.37	0.65	0.67
		302	1.14	1.24	0.83	0.93	0.81	1.14	0.81	1.08	0.67
SIZE 4	R0450X	158	0.89	0.98	0.49	0.59	0.69	0.98	0.87	1.14	0.79
		302	1.04	1.14	0.65	0.75	1.14	1.46	1.30	1.57	0.79
	Size 5	R01800X	158	0.47	0.75	0.51	0.91	0.43	0.75	0.67	1.00



Clearances are set at the time of original build and may move small amounts during operation. They will however, remain within the published limits.

It is recommended that clearances are always checked and corrected (if necessary) during any periodic maintenance of the product.

6.2 Fasteners & Torque Settings.

Description	Position		Size 2	Size 3	Size 4	Size 5	Size 5
						1800	2200 + 2600
Dome Nut	Front Cover / Rotorcase	Qty / Pump	4	4	8	8	8
		Size - mm	M8	M10	M12	M12	M12
		Torque - Nm	17	45	55	75	55
		Torque - lbf ft	12.54	33.19	40.57	55.32	40.57
Rotor Retainer plate	Retainer Plate / Shaft	Qty / Pump				6	6
		Size - mm	N/A	N/A	N/A	M12	M12
		Torque - Nm				55	55
		Torque - lbf ft				40.57	40.57
Rotor Retainer	Rotor Retainer / Retainer Plate	Qty / Pump	2	2	2	2	2
		Size - mm	M10	M12	M16	M8	M8
		Torque - Nm	45	40	108	17	17
		Torque - lbf ft	33.19	29.50	79.66	12.54	12.54
Stud	Front Cover / Rotorcase	Qty / Pump	4	4	8	8	8
		Size - mm	M8	M10	M12	M12	M12
		Torque - Nm	17	17	55	75	55
		Torque - lbf ft	12.54	12.54	40.57	55.32	40.57
Button Head Cap Screw	Anti-Rotation Washer / Rotorcase	Qty / Pump	2	2	2	2	2
		Size - mm	M6	M8	M10	M8	M8
		Torque - Nm	7	17	45	17	17
		Torque - lbf ft	5.16	12.54	33.19	12.54	12.54
Stud	Gearbox Housing / Front Cover	Qty / Pump	4	4	8	8	8
		Size - mm	M8	M10	M12	M12	M12
		Torque - Nm	17	45	55	55	55
		Torque - lbf ft	12.54	33.19	40.57	40.57	40.57
Socket Cap Head Screw	Rotorcase / Bearing Housing	Qty / Pump	2	2	2	2	2
		Size - mm	M6	M6	M6	M12	M12
		Torque - Nm	7	7	7	55	55
		Torque - lbf ft	5.16	5.16	5.16	40.57	40.57
Drive Shaft / Driven Shaft	Bearing Housing / Gearbox Housing	Rolling Torque Nm	0.6 - 2.6	1 - 3.3	1.4 - 6	4.6 - 15.6	4.6 - 15.6
		Rolling Torque lbf ft	0.4 - 1.9	0.7 - 2.4	1.0 - 4.4	3.4 - 11.5	3.4 - 11.5
Button Cap Head Screw	Bearing Retainer	Qty / Pump	6	6	6	10	10
		Size - mm	M6	M8	M10	M8	M8
		Torque - Nm	7	17	45	17	17
		Torque - lbf ft	5.16	12.54	33.19	12.54	12.54
Locknut	Timing Gear / Shaft	Qty / Pump	2	2	2	2	2
		Size - mm	M30	M45	M55	M80	M80
		Torque - Nm	100	125	170	220	220
		Torque - lbf ft	73.76	92.20	125.39	162.26	162.26
Socket Cap Head Screw	Feet	Qty / Pump	4	4	4	4	4
		Size - mm	M8	M8	M10	M12	M12
		Torque - Nm	17	17	45	55	55
		Torque - lbf ft	12.54	12.54	33.19	40.57	40.57
Socket Cap Head Screw	Rear Cover / Gearbox	Qty / Pump	6	6	6	6	6
		Size - mm	M6	M8	M10	M10	M10
		Torque - Nm	7	17	45	45	45
		Torque - lbf ft	5.16	12.54	33.19	33.19	33.19

6.3 Lubricants.

The Revolution has 2 lubrication options available gear oil and grease, the following lubricants are recommended for use with Revolution

	Food Grade Lubricants (NSF H1 Conforming Food Grade lubricants)	Standard Mineral Oil Based Lubricants
Gear Oil	Petro-Canada Purity FG EP Gear Oil EP220	EP150 - ambient temp range -20 to 0 deg Celsius EP220 - ambient temp range 0 to 30 deg Celsius EP320 – ambient temp range 30 deg Celsius and higher
Grease (Semi-Fluid Grease)	N/A	Petro-Canada Precision XL EP00 Aralube MFL 00 Mobilux EP 004 BP Energrease PR-EP 00 Shell Retinax CS 00

Approximate grease capacities for the Revolution.:

Size 2	0.42 Litres (0.11 US Gallons)
Size 3	0.85 Litres (0.22 US Gallons)
Size 4	3 Litres (0.79 US Gallons)
Size 5	4.4 Litres (1.16 US Gallons)

**** Note: For oil always add to the middle of the sight glass.**

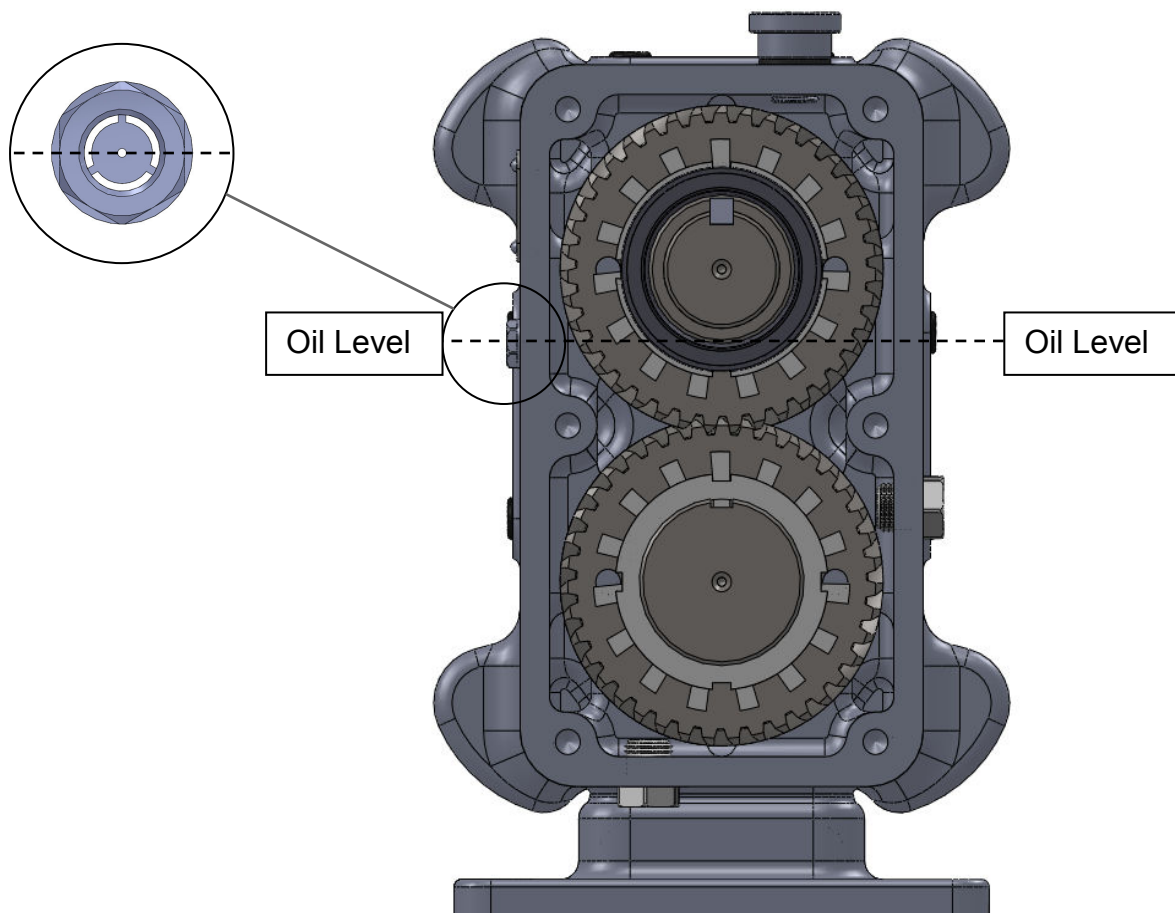

Frame 2,3 and 4 Vertical port arrangement - Sight glass located in the uppermost position on the side of the gearbox

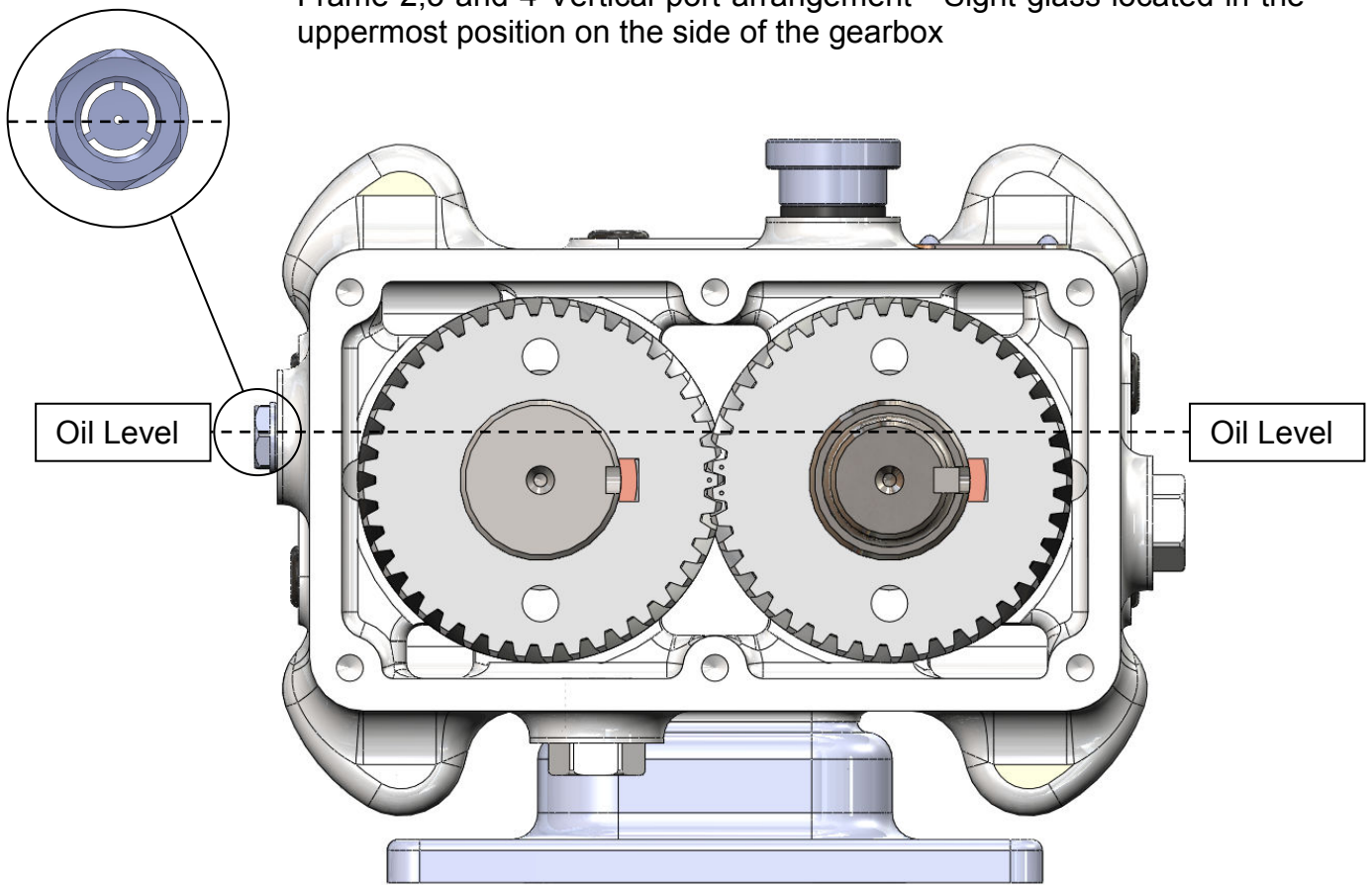

Frame 5 Only - Sight glass located in the lowermost position on the side of the gearbox

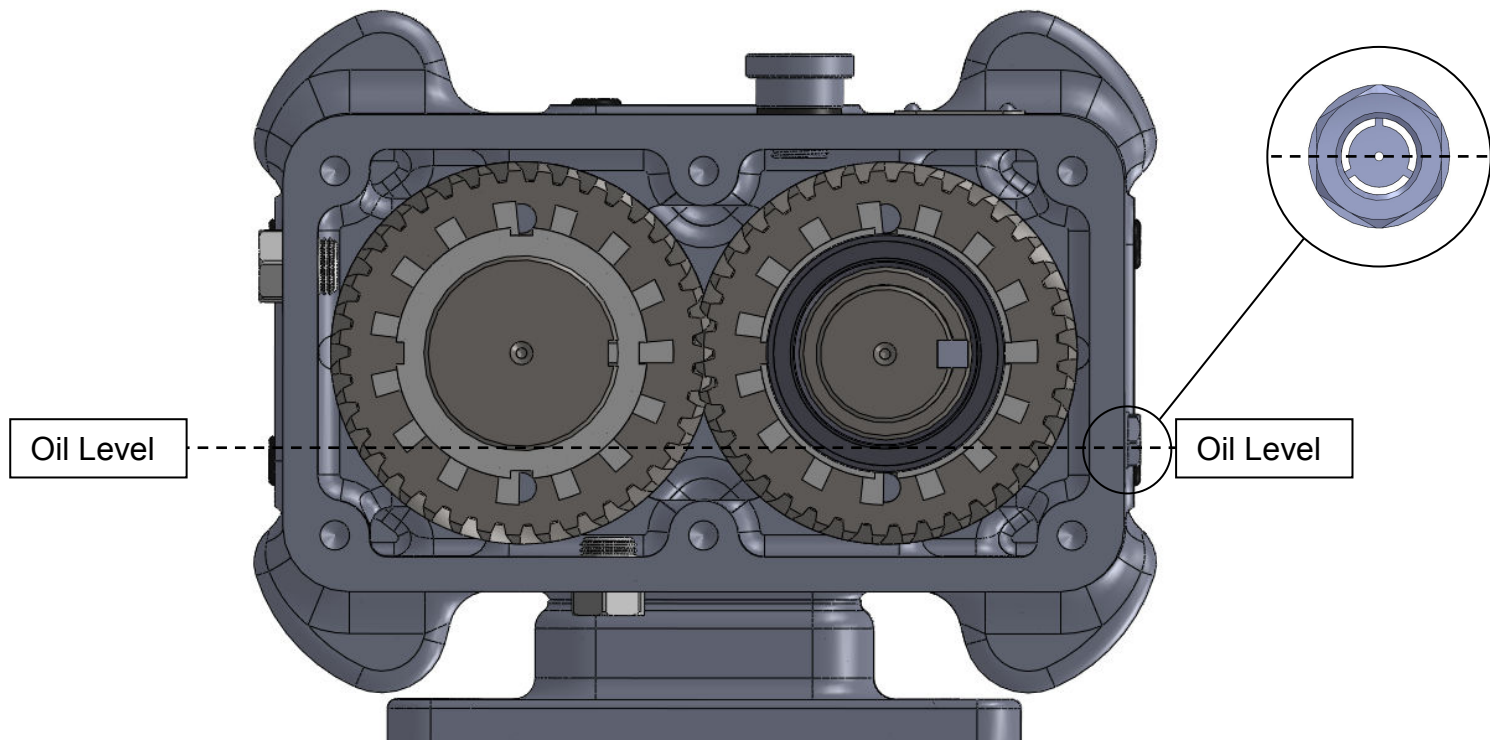

6.3 Material Specifications and Pump Weights.

Rotorcase	316L St.Steel
Front Cover	316L St.Steel
Rotors	316L St.Steel Or Alloy 808
Rotor Retainers	316L St.Steel
Shafts	316L St.Steel
Setting Ring	316L St.Steel
Gearbox	Cast Iron 250 / 304 St.Steel
Gearbox Cover	Cast Iron 250 / 304 St.Steel
Foot	304 St.Steel

Pump Weights	Kg	lbs
R0150X	22	48.5
R0180X	26	58
R0200X	44	97
R0300X	45	99
R0400X	46	101
R0600P	96	212
R1300X	105	231

6.5 Pump Lifting.

The Revolution pump has been designed with 4 Metric threaded locations on each side of the gearbox for lifting the pump.

WARNING

Note

- 1) these lifting point have been designed to carry the weight of the pump only, if the pump has been installed / mounted these lifting point cannot be used.
- 2) On lifting two certified lifting eyes must be used in conjunction with a correctly rated lifting sling

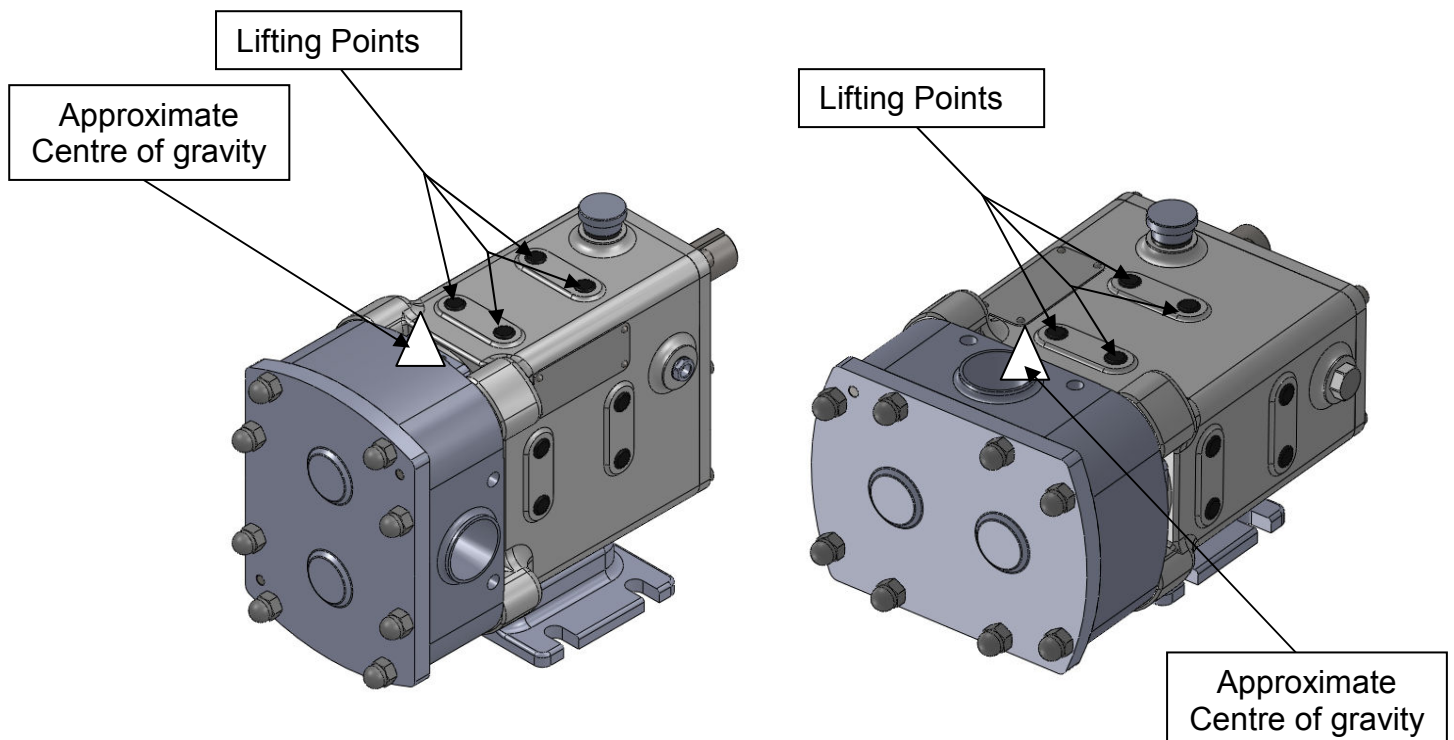

6.6 Foundation Dimensions.

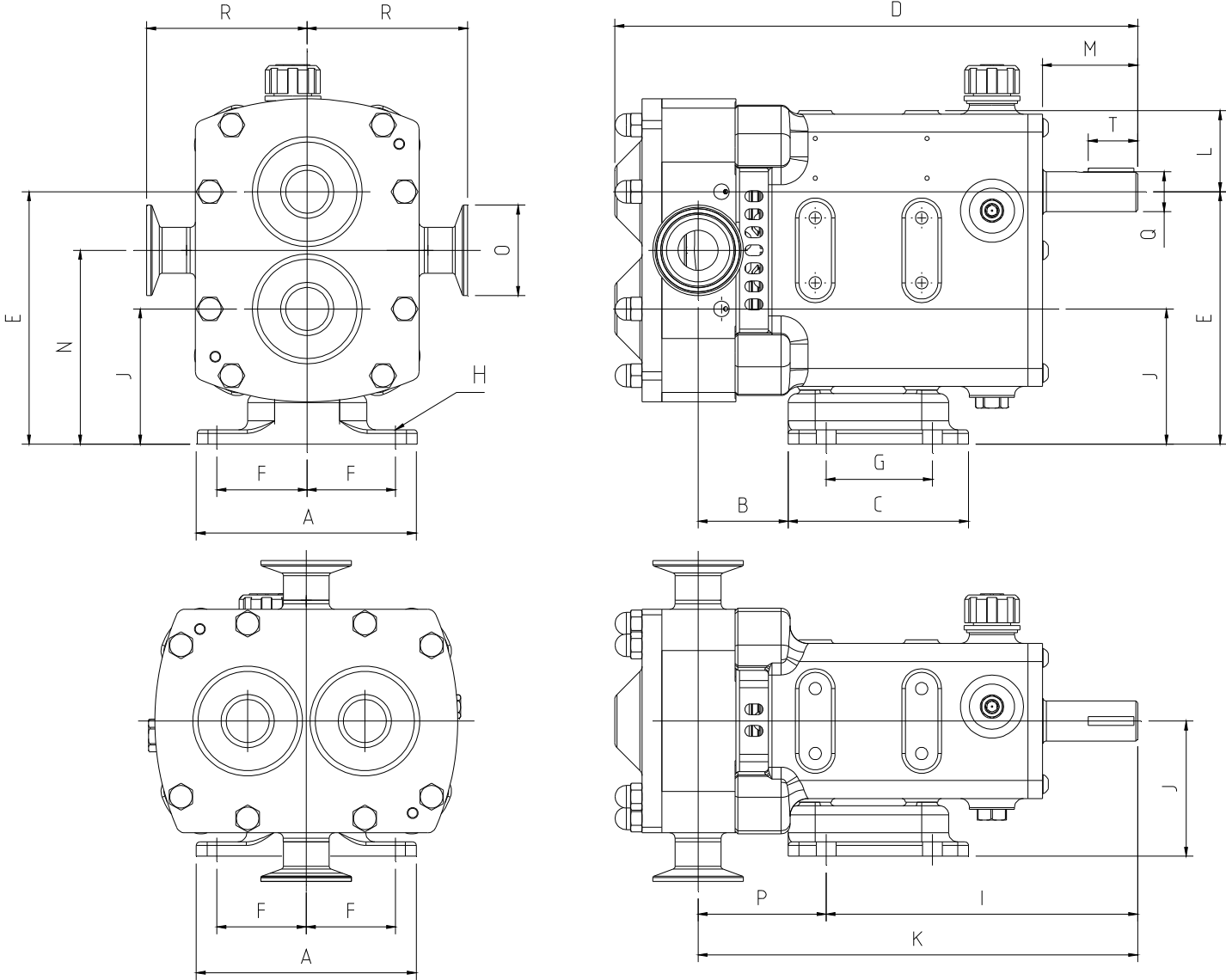

Metric Dimensions

	Pump Type	Model	A	B	C	D	E	F	G	H	I	J	K	L	M	N	O	P	Q	R1	S	T
Size 2	CPP	R0150X	122	50	100	290	140	49	59	11 x 12	173	75	244	45	53	107.5	25/38	71	22.2	89	178	4.76 X 25.4
	RLP	R0150X	122	50	100	280.5	140	49	59	11 x 12	173	75	244	45	53	107.5	25	71	22.2	89	178	4.76 X 25.4
	RLP	R0160L	122	52	100	279.5	140	49	59	11 x 12	173	75	246	45	53	107.5	38	73	22.2	89	178	4.76 X 25.4
	CPP	R0180P	122	56	100	291	140	49	59	11 x 12	173	75	250	45	53	107.5	38	77	22.2	89	178	4.76 X 25.4
	RLP	R0180L	122	56	100	286	140	49	59	11 x 12	173	75	250	45	53	107.5	38	77	22.2	89	178	4.76 X 25.4
Size 3	CPP	R0200X	146	70	104	346.5	174	59	65	11 x 14	202	90	291	57	68	132	38	89	31.75	108	216	6.35 x 45
	RLP	R0200X	146	70	104	337	174	59	65	11 x 14	202	90	291	57	68	132	38	89	31.75	108	216	6.35 x 45
	CPP	R0300X	146	73.5	104	346.5	174	59	65	11 x 14	202	90	294.5	57	68	132	38	92.5	31.75	108	216	6.35 x 45
	RLP	R0300X	146	73.5	104	347	174	59	65	11 x 14	202	90	294.5	57	68	132	38	92.5	31.75	108	216	6.35 x 45
	CPP	R0400X	146	80	104	356.5	174	59	65	11 x 14	202	90	301	57	68	132	50	99	31.75	108	216	6.35 x 45
	RLP	R0400X	146	80	104	357	174	59	65	11 x 14	202	90	301	57	68	132	50	99	31.75	108	216	6.35 x 45
Size 4	CPP	R0450X	210	89	166	457.7	243	89	105	13 x 16	256	129	377	78	78	186	51	121	41.2	136	272	9.53 x 41.25
	RLP	R0450X	210	89	166	443	243	89	105	13 x 16	256	129	377	78	78	186	51	121	41.2	136	272	9.53 x 41.25
	CPP	R0600P	210	91	166	467.7	243	89	105	13 x 16	256	129	385	78	78	186	64	129	41.2	136	272	9.53 x 41.25
	CPP	R0800X	210	106.5	166	457.7	243	89	105	13 x 16	256	129	394.5	78	78	186	64	138.5	41.2	136	272	9.53 x 41.25
	RLP	R0800X	210	106.5	166	465	243	89	105	13 x 16	256	129	394.5	78	78	186	64	138.5	41.2	136	272	9.53 x 41.25
	CPP	R1300X	210	113	166	472.7	243	89	105	13 x 16	256	129	401	78	78	186	76	145	41.2	136	272	9.53 x 41.25
	RLP	R1300X	210	113	166	480	243	89	105	13 x 16	256	129	401	78	78	186	76	145	41.2	136	272	9.53 x 41.25
Size 5	CPP	R1800X	216	77	256	566	314	95	184	13X19.5	357	161.5	464	104.75	70.5	237.75	72.3	107	50.8	168.5	337	12.7 X 50.8
	CPP	R2200X	216	77	256	570	314	95	184	13X19.5	357	161.5	470	104.75	70.5	237.75	97.5	113	50.8	168.5	337	12.7 X 50.8
	CPP	R2600P	216	77	256	589	314	95	184	13X19.5	357	161.5	496	104.75	70.5	237.75	97.5	139	50.8	168.5	337	12.7 X 50.8

Notes: Dimensions given are for guidance only and should not be used for installation purposes.
 Certified dimensions can be supplied on request.

R1 applies to Tri-Clamp fittings only

Imperial Dimensions

	Pump Type	Model	A	B	C	D	E	F	G	H	I	J	K	L	M	N	O	P	Q	R1	S	T
Size 2	CPP	R0150X	4.80	1.97	3.94	11.42	5.51	1.93	2.32	0.43 x 0.47	6.81	2.95	9.61	1.77	2.09	4.23	0.98/1.5	2.80	0.87	3.50	7.01	0.187" x 1"
	RLP	R0150X	4.80	1.97	3.94	11.04	5.51	1.93	2.32	0.43 x 0.47	6.81	2.95	9.61	1.77	2.09	4.23	0.98	2.80	0.87	3.50	7.01	0.187" x 1"
	RLP	R0160L	4.80	2.05	3.94	11.00	5.51	1.93	2.32	0.43 x 0.47	6.81	2.95	9.69	1.77	2.09	4.23	1.50	2.87	0.87	3.50	7.01	0.187" x 1"
	CPP	R0180P	4.80	2.20	3.94	11.46	5.51	1.93	2.32	0.43 x 0.47	6.81	2.95	9.84	1.77	2.09	4.23	1.50	3.03	0.87	3.50	7.01	0.187" x 1"
	RLP	R0180L	4.80	2.20	3.94	11.26	5.51	1.93	2.32	0.43 x 0.47	6.81	2.95	9.84	1.77	2.09	4.23	1.50	3.03	0.87	3.50	7.01	0.187" x 1"
Size 3	CPP	R0200X	5.75	2.76	4.09	13.64	6.85	2.32	2.56	0.43 x 0.55	7.95	3.54	11.46	2.24	2.68	5.20	1.50	3.50	1.25	4.25	8.50	0.25" x 1.77"
	RLP	R0200X	5.75	2.76	4.09	13.27	6.85	2.32	2.56	0.43 x 0.55	7.95	3.54	11.46	2.24	2.68	5.20	1.50	3.50	1.25	4.25	8.50	0.25" x 1.77"
	CPP	R0300X	5.75	2.89	4.09	13.64	6.85	2.32	2.56	0.43 x 0.55	7.95	3.54	11.59	2.24	2.68	5.20	1.50	3.64	1.25	4.25	8.50	0.25" x 1.77"
	RLP	R0300X	5.75	2.89	4.09	13.66	6.85	2.32	2.56	0.43 x 0.55	7.95	3.54	11.59	2.24	2.68	5.20	1.50	3.64	1.25	4.25	8.50	0.25" x 1.77"
	CPP	R0400X	5.75	3.15	4.09	14.04	6.85	2.32	2.56	0.43 x 0.55	7.95	3.54	11.85	2.24	2.68	5.20	1.97	3.90	1.25	4.25	8.50	0.25" x 1.77"
	RLP	R0400X	5.75	3.15	4.09	14.06	6.85	2.32	2.56	0.43 x 0.55	7.95	3.54	11.85	2.24	2.68	5.20	1.97	3.90	1.25	4.25	8.50	0.25" x 1.77"
Size 4	CPP	R0450X	8.27	3.50	6.54	18.02	9.57	3.50	4.13	0.51 x 0.63	10.08	5.08	14.84	3.07	3.07	7.32	2.01	4.76	1.62	5.35	10.71	0.375" x 1.62"
	RLP	R0450X	8.27	3.50	6.54	17.44	9.57	3.50	4.13	0.51 x 0.63	10.08	5.08	14.84	3.07	3.07	7.32	2.01	4.76	1.62	5.35	10.71	0.375" x 1.62"
	CPP	R0600P	8.27	3.58	6.54	18.41	9.57	3.50	4.13	0.51 x 0.63	10.08	5.08	15.16	3.07	3.07	7.32	2.52	5.08	1.62	5.35	10.71	0.375" x 1.62"
	CPP	R0800X	8.27	4.19	6.54	18.02	9.57	3.50	4.13	0.51 x 0.63	10.08	5.08	15.53	3.07	3.07	7.32	2.52	5.45	1.62	5.35	10.71	0.375" x 1.62"
	RLP	R0800X	8.27	4.19	6.54	18.31	9.57	3.50	4.13	0.51 x 0.63	10.08	5.08	15.53	3.07	3.07	7.32	2.52	5.45	1.62	5.35	10.71	0.375" x 1.62"
	CPP	R1300X	8.27	4.45	6.54	18.61	9.57	3.50	4.13	0.51 x 0.63	10.08	5.08	15.79	3.07	3.07	7.32	2.99	5.71	1.62	5.35	10.71	0.375" x 1.62"
	RLP	R1300X	8.27	4.45	6.54	18.90	9.57	3.50	4.13	0.51 x 0.63	10.08	5.08	15.79	3.07	3.07	7.32	2.99	5.71	1.62	5.35	10.71	0.375" x 1.62"
Size 5	CPP	R1800X	8.50	3.03	10.08	22.28	12.36	3.74	7.24	0.51 x 0.77	14.06	6.36	18.27	4.12	2.78	9.36	2.85	4.21	2.00	6.63	13.27	0.5" x 2"
	CPP	R2200X	8.50	3.03	10.08	22.44	12.36	3.74	7.24	0.51 x 0.77	14.06	6.36	18.50	4.12	2.78	9.36	3.84	4.45	2.00	6.63	13.27	0.5" x 2"
	CPP	R2600P	8.50	3.03	10.08	23.19	12.36	3.74	7.24	0.51 x 0.77	14.06	6.36	19.53	4.12	2.78	9.36	3.84	5.47	2.00	6.63	13.27	0.5" x 2"

Notes: Dimensions given are for guidance only and should not be used for installation purposes.
 Certified dimensions can be supplied on request.

R1 applies to Tri-Clamp fittings only

6.7 Trouble Shooting.

No Flow	IRREGULAR FLOW	UNDER CAPACITY	PUMP OVERHEATS	MOTOR OVERHEATS	EXCESSIVE ROTOR WEAR	EXCESSIVE SEAL WEAR	NOISE / VIBRATION	SEIZURE	PUMP STALLS ON START UP	Causes	ACTION
										INCORRECT DIRECTION OF ROTATION.	REVERSE MOTOR.
										PUMP NOT PRIMED.	EXPEL GAS FROM SUCTION LINE / PUMP CHAMBER & PRIME.
										INSUFFICIENT NPSH AVAILABLE.	INCREASE SUCTION LINE & STATIC SUCTION HEAD DIAMETER. SIMPLIFY SUCTION LINE & REDUCE LENGTH. REDUCE PUMP SPEED & PRODUCT TEMPERATURE.
										PRODUCT VAPORISING IN SUCTION LINE.	
										AIR ENTERING SUCTION LINE.	REMAKE PIPEWORK JOINTS.
										GAS IN SUCTION LINE.	EXPEL GAS FROM SUCTION LINE / PUMP CHAMBER.
										INSUFFICIENT STATIC SUCTION HEAD.	RAISE PRODUCT LEVEL TO INCREASE STATIC SUCTION HEAD.
										PRODUCT VISCOSITY TOO HIGH.	DECREASE PUMP SPEED / INCREASE PRODUCT TEMPERATURE.
										PRODUCT VISCOSITY TOO LOW.	INCREASE PUMP SPEED / INCREASE PRODUCT TEMPERATURE.
										PRODUCT TEMPERATURE TOO HIGH.	COOL PRODUCT / PUMPING CHAMBER.
										PRODUCT TEMPERATURE TOO LOW.	HEAT PRODUCT / PUMPING CHAMBER.
										UNEXPECTED SOLIDS IN PRODUCT	CLEAN SYSTEM / FIT STRAINER ON SUCTION SIDE OF PUMP.
										DISCHARGE PRESSURE TOO HIGH	CHECK FOR BLOCKAGES / SIMPLIFY DISCHARGE LINE.
										ROTORCASE STRAINED BY PIPEWORK.	CHECK PIPE ALIGNMENT / SUPPORT PIPEWORK.
										PUMP SPEED TOO HIGH	DECREASE PUMP SPEED.
										PUMP SPEED TOO LOW	INCREASE PUMP SPEED
										SEAL FLUSH INADEQUATE	INCREASE SEAL FLUSH TO REQUIRED PRESSURE / FLOW.
										BEARING / TIMING GEAR WEAR	REPLACE WORN COMPONENTS.

6.8 Typical Noise Emission Data.

TBA

6.9 Tool List.

Listed below are tools required for the maintenance for the Revolution.

TYPE	SIZE OR RANGE	Size 2	Size 3	Size 4	Size 5
Combination Spanner	13 mm	•			
Combination Spanner	17 mm	•	•		
Combination Spanner	19 mm			•	•
Combination Spanner	26 mm			•	•
Combination Spanner	27 mm			•	•

Hexagon (Allen) Key	4 mm	•	•		
Hexagon (Allen) Key	5 mm	•	•	•	•
Hexagon (Allen) Key	6 mm	•	•	•	•
Hexagon (Allen) Key	8 mm			•	•
Hexagon (Allen) Key	10 mm				•

Hexagon (Allen) Key (Socket Driven)	4 mm	•	•		
Hexagon (Allen) Key (Socket Driven)	5 mm	•	•	•	•
Hexagon (Allen) Key (Socket Driven)	6 mm	•	•	•	•
Hexagon (Allen) Key (Socket Driven)	8 mm			•	•
Hexagon (Allen) Key (Socket Driven)	10mm				•

TYPE	SIZE OR RANGE	Size 2	Size 3	Size 4	Size 5
Torque Wrench	Adjustable to Min. 125 Nm(92.20 ft-lb.)	•	•	•	•
Torque Wrench	Adjustable to Min. 170 Nm (125.39 ft-lb.)		•	•	•
Torque Wrench	Adjustable to Min. 220 Nm (162.27ft-lb.)				•

Depth Micrometer	0 - 25 mm (0 - 1")	•	•	•	•
Feeler Gauge Set		•	•	•	•
Micrometer	0 – 25 mm (0 – 1")	•	•	•	•
Rolling Torque Meter	0 - 5 Nm (0 - 3.68 ft-lb.)	•	•	•	
Rolling Torque Meter	0 - 20 Nm (0 – 14.75 ft-lb.)				•
Rotor Retainer Socket	Supplied with Pump	•	•	•	•

C – Spanner	To Suit Locknut Ø38.0 mm (1.496")	•			
C – Spanner	To Suit Locknut Ø65.0 mm (2.559")		•		
C – Spanner	To Suit Locknut Ø75.0 mm (2.953")			•	
C – Spanner	To Suit Locknut Ø110.0 mm (4.331")				•
Soft Faced Mallet		•	•	•	•
Screwdriver	Flat Blade, Medium	•	•	•	•
Circlip Pliers	Internal	•	•	•	•
Pin Punch	Small	•	•	•	•
Steel Hammer	Small	•	•	•	•

7.0 Service History.

Pump Model:

Pump Serial No:

Date	Comments

7.1 Notes

The information contained in this document is correct at time of print, but may be subject to change without prior notice.



Wright Flow Technologies Ltd.
Edison Road, Eastbourne,
East Sussex, BN23 6PT
United Kingdom

Phone: +44 1323 509211
Fax: +44 1323 507306
E-mail: wright.eu@idexcorp.com

Wright Flow Technologies, Inc.
406 State Street
Cedar Falls, Iowa 50613 U.S.A.

Phone: (319) 268-8013
Fax: (803) 216-7686
E-mail: wright.usa@idexcorp.com

www.wrightflowtechnologies.com